

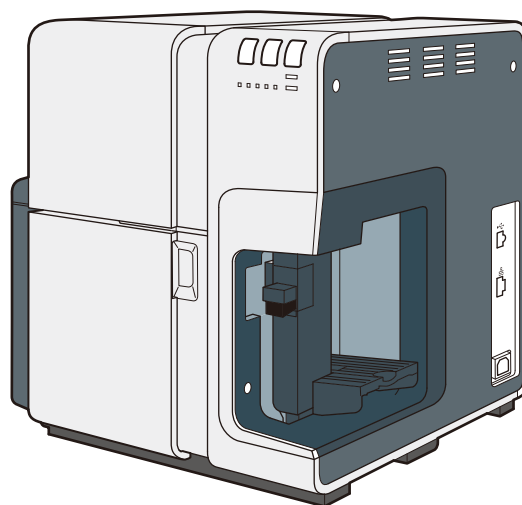

swiftcolor[™]
SCC-4000D

USER'S GUIDE



How to Use This Guide & CD-ROM

Start Guide

You should read this start guide first if this is the first time you are using this printer.

The Start Guide describes precautions for using the printer safely and shows you how to prepare the printer (software installation, etc.) before you use it.

Printer Software (Provided on the CD-ROM)

The CD-ROM contains printer driver and User's Guide.

■ Printer Driver

The printer driver is the software for using this product under Windows 7/Windows Vista/Windows XP.

■ User's Guide

This electronic manual describes the basic procedures for using the printer. Specifically, the User's Guide explains the basic print procedures, how to maintain the printer, how to troubleshoot problems, and describes all the features of the printer and printer driver.

You can find and display desired information in accordance with the Contents and Index.

To view the User's Guide, Adobe Reader/Adobe Acrobat Reader is required. If Adobe Reader/Adobe Acrobat Reader is not installed in your computer, download it from the website of Adobe Systems Inc. And install it in your computer.

Help Functions

In addition to the Start Guide and the User's Guide, the printer driver provides online Help to find answers to questions about printer features and operations and how to troubleshoot problems while you are using the printer driver.

Click the Help button on the printer driver screens or in the menu bar to open online Help.

Contents

How to Use This Guide & CD-ROM i

Start Guide	i
Printer Software (Provided on the CD-ROM).....	i
Help Functions	i

Before You Begin 1

Conventions	1
Illustrations and Sample Screens	1
Trademarks.....	2
Abbreviations	2
Request to the Customer	2
Legal Notice	3
Legal Limitations on the Usage of Your Product and the Use of Images	3
Product Name	3
CE	3
FCC (Federal Communications Commission).....	4

1. Before Using the Printer..... 5

1-1 Printer Part Names and Functions	5
1-1-1. Front/ Right Side View	5
1-1-2. Left Side /Rear View	7
1-1-3. Inside the Printer.....	8
1-1-4. Operation Panel.....	9
1-1-5. Online and Sleep Modes	10
1-2 Connecting the Printer and Computer.....	11
1-2-1. Connecting with USB Cable.....	12

1-2-2. Connecting with LAN Cable.....	13
1-3 Switching the Printer On and Off	14
1-3-1. Switching the Printer On	14
1-3-2. Switching the Printer Off.....	15
1-4 Paper Loading Procedure	16
1-5 For the use of Plastic Card	24
2. How to Print.....	31
2-1 How to Make of Print Data.....	31
2-2 Canceling Print Jobs	34
2-2-1.Canceling Print Jobs from the Status Monitor.....	34
2-3 Pausing Printing	35
2-3-1.Pause from the Operation Panel	35
2-3-2.Cleaning During Pause Stop	36
3. How to Use the Printer Driver	39
3-1 Opening the Printing Preferences Dialog Box.....	39
3-1-1.Opening from the Application Software.....	39
3-1-2. Opening from the Start Menu	41
3-2 Using the Page Setup Dialog Box	43
3-2-1. Registration of Favorites	45
3-2-2. Deletion of Favorites.....	48
3-2-3. Using Print Setting Registered in Favorite.....	51
3-2-4. Paper Size	53
3-2-5. Custom Paper Size Settings.....	56
3-2-6.Paper Type	61
3-2-7.Orientation	62
3-2-8.Check Settings	64

3-2-9. Version Information	65
3-3 Using the Color Dialog Box	66
3-3-1. Color Adjustment	67
3-3-2. Set Print Quality	69
3-3-3. Single Color Setting	70
3-4 Using the Detailed Settings Dialog Box	72
3-4-1. Color Balance	72
3-4-2. Brightness	73
3-4-3. Density	74
3-4-4. Contrast	75
3-4-5. Halftone Process	76
3-4-6. Level Correction	77
3-4-7. Sharpness	78
3-5 Using the Overlay Settings Dialog Box	79
3-5-1. Create Form	81
3-5-2. Overlay Printing	84
3-6 Using the Advanced Dialog Box	87
3-6-1. Print Order	89
3-6-2. Paper Feed Interval	89
3-7 Using the Utility Dialog box	91
3-7-1. Sleep	94
3-7-2. Sleep Timer Setting	96
3-7-3. Pinpoint Color Matches	99
3-7-4. Special Settings	111
3-7-5. Add Custom Paper Type	114

4. How to Use the Status Monitor.....	119
4-1 Displaying the Status Monitor	119
4-1-1. Starting the Status Monitor	119
4-1-2. How to Start and Display the Status Monitor	121
4-2 Using the Status Monitor	124
4-2-1. Viewing the Print Status.....	125
4-2-2. Viewing the Printer Status	127
4-2-3. Viewing Ink Information	131
4-2-4. Viewing Maintenance Cartridge Information	133
5. Printer Maintenance	135
5-1 Cleaning the Printhead.....	135
5-1-1. Cleaning	135
5-2 Adjusting the Printhead Position	137
5-3 Detailed Printhead Position Adjustment	153
5-4 Check the Output Setting Value.....	162
5-5 Replacing Ink Tanks	164
5-6 Replacing the Maintenance Cartridge.....	171
5-7 Used Ink Tanks.....	176
5-8 Used Maintenance Cartridge.....	176
5-9 Cleaning the Printer	177
6. Troubleshooting.....	181
6-1 Error or Warning Messages.....	181
6-2 When Paper is Jammed	186
6-3 Printer Not Operating Correctly	189

6-4 Print Results Are Unsatisfactory 193

7. Appendix.....201

7-1 Moving The Printer.....201

7-2 Shipping the Printer.....205

7-3 Software Uninstallation.....209

7-4 Network Utility 211

7-4-1. Toolbar213

7-4-2. Menu bar213

7-4-3. Settings214

7-4-4. Display..... 221

7-4-5. Environmental settings 221

7-4-6. Help..... 225

Specifications.....226

Index227

Before You Begin

Thank you for purchasing the Swiftcolor SCC-4000D.

Please read this guide before you use the printer so you can fully understand the printer features and learn how to use the printer most efficiently. This guide provides all the information you need to use this printer.

Conventions

The following marks are used in this guide.

Warning

Indicates a warning concerning operations that may lead to death or injury to persons if not performed correctly. To use the machine safely, always pay attention to these warnings.

Caution

Indicates a caution concerning operations that may lead to injury to persons if not performed correctly. To use the machine safely, always pay attention to these cautions.

Important

Indicates operational requirements and restrictions. Be sure to read these items carefully to operate the machine correctly, and avoid damage to the machine or property.

Note

Indicates a clarification of an operation, or contains additional explanations for a procedure. Reading these notes is highly recommended.



Indicates an operation that must not be performed. Read these items carefully, and make sure not to perform the described operations.

Illustrations and Sample Screens

The illustrations and the sample screens of the printer driver settings in this guide are created with Swiftcolor SCC-4000D in Windows 7. The contents of these printer driver screens and instructions are essentially the same as Windows Vista and Windows XP as well as those for Swiftcolor SCL-4000P; however, explanations are provided when there are minor differences in screen content or procedures.

Trademarks

- Microsoft and Windows are trademarks of Microsoft Corporation in the United States and/or other countries.
- Adobe and the Adobe logo are trademarks of Adobe Systems, Inc.
- Other brand and product names may be trademarks or registered trademarks of their respective companies.

Abbreviations

Throughout this document the following abbreviations are used in text.

- Microsoft Windows 8 is abbreviated as “Windows 8”.
- Microsoft Windows 7 is abbreviated as “Windows 7”.
- Microsoft Windows Vista is abbreviated as “Windows Vista”.
- Microsoft Windows XP is abbreviated as “Windows XP”.
- Microsoft Windows is abbreviated as “Windows”.

Request to the Customer

- Copying this guide or any part of this guide without permission is strictly forbidden.
- The specifications for this printer as well as the software provided with the printer are subject to change without prior notice.
- We have done our best to make this guide as complete and accurate as possible, and we ask you to contact the dealer where you purchased the printer if you find any omissions or mistakes in this document.
- We can accept no responsibility for loss or damages resulting from the use of this printer or its software; please accept this before you use the printer.

Legal Notice

Legal Limitations on the Usage of Your Product and the Use of Images

- It is illegal to reproduce currency, bills, negotiable securities and other documents prohibited by law. Reproduction of such items may be subject to criminal prosecution.
- It is illegal to reproduce legal certificates, licenses, and certain public and private documents prohibited from reproduction by law. Reproduction of such items may be subject to criminal prosecution.
- Please note that intellectual property protected by copyright may not be reproduced without the express permission of the copyright holder except for personal or household use under limited circumstances.

Product Name

SCC-4000D

CE

This equipment conforms with the essential EMC requirements of EC Directive. We declare that this product conforms with the EMC requirements of EC Directive at nominal mains input 230V, 50 Hz although the rated input of the product is 100 to 240 V, 50/60 Hz. Use of shielded cable is necessary to comply with the technical EMC requirements of EC Directive.

FCC (Federal Communications Commission)

FCC Part 15 Compliance

NOTE: This equipment has been tested and found to comply with the limits for a Class B digital device, pursuant to part 15 of the FCC rules. These limits are designed to provide reasonable protection against interference in a residential installation. This equipment generates, uses, and can radiate radio frequency energy and, if not installed and used in accordance with the instruction manual, may cause interference to radio communications. However, there is no guarantee that interference will not occur in a particular installation. If this equipment does cause interference to radio or television reception, which can be determined by turning the equipment off and on, the user is encouraged to try to correct the interference by one or more of the following measures:

- Reorient or relocate the receiving antenna.
- Increase the separation between the equipment and receiver.
- Connect the equipment into an outlet on a circuit different from that to which the receiver is connected.
- Consult the dealer or an experienced radio/TV technician for help.

CAUTION: Changes or modifications to this equipment not expressly approved by the party responsible for compliance could void the user's authority to operate the equipment.

1. Before Using the Printer

This section describes how to prepare the printer and procedures you should know before you use the printer.

1-1 Printer Part Names and Functions

The name and function of each part is described below.

1-1-1. Front/ Right Side View

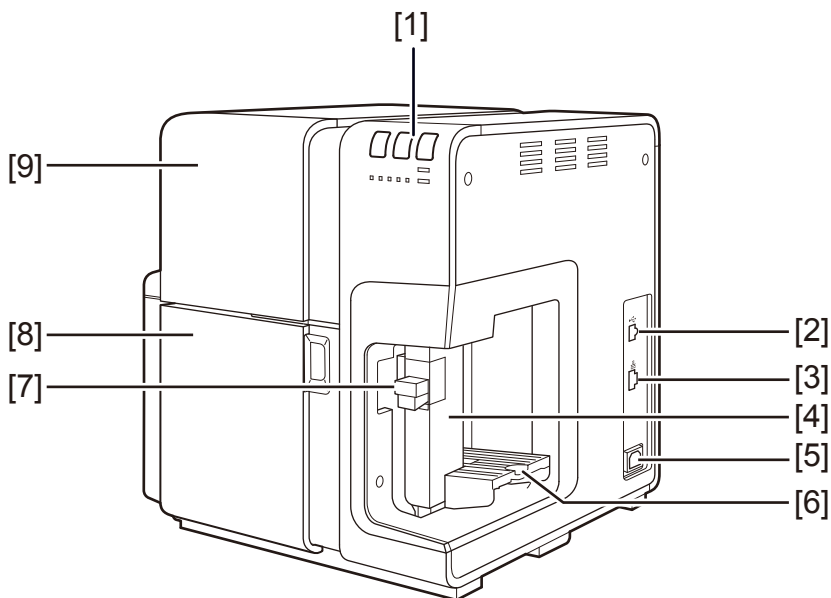

[1] Operation panel

Keys necessary for operation and lamps to indicate the state of printer are provided on this panel.

[2] USB port

Connect a USB cable here to connect to the computer.

[3] LAN port

Connect a LAN cable here to connect to the computer.

1. Before Using the Printer

[4] **Side guide**

Adjust the position of this guide according to the paper width.

[5] **Power socket**

Connect the power cord here.

[6] **Feeder tray**

Load the paper.

[7] **Side guide lever**

Use this lever to move the side guide.

[8] **Ink tank door**

Open this door when replacing ink tanks or opening the upper unit.

[9] **Upper unit**

Open this unit when or removing the paper jammed in the paper feed path or cleaning inside of the machine. Printheads are installed inside .

1-1-2. Left Side /Rear View

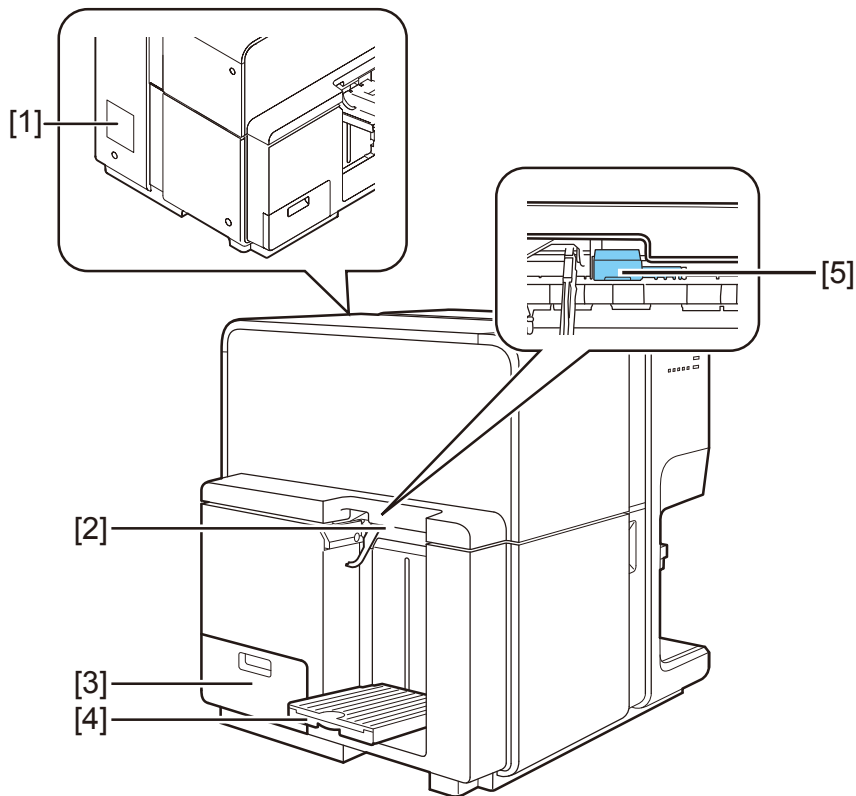

[1] Rating plate

A serial number for identifying the printer is shown on this plate. (The serial number is required when you ask for repair of the printer.)

[2] Paper delivery slot

Paper is ejected through this slot.

[3] Maintenance cartridge door

Open this door when replacing the maintenance cartridge.

[4] Auto stacker

Receives printed paper output from the printer. (The tray lowers automatically in accordance with the loaded amount of printing media.)

[5] Thick paper transport lever

It is a lever that is used when you use the thick paper and plastic card.

1-1-3. Inside the Printer

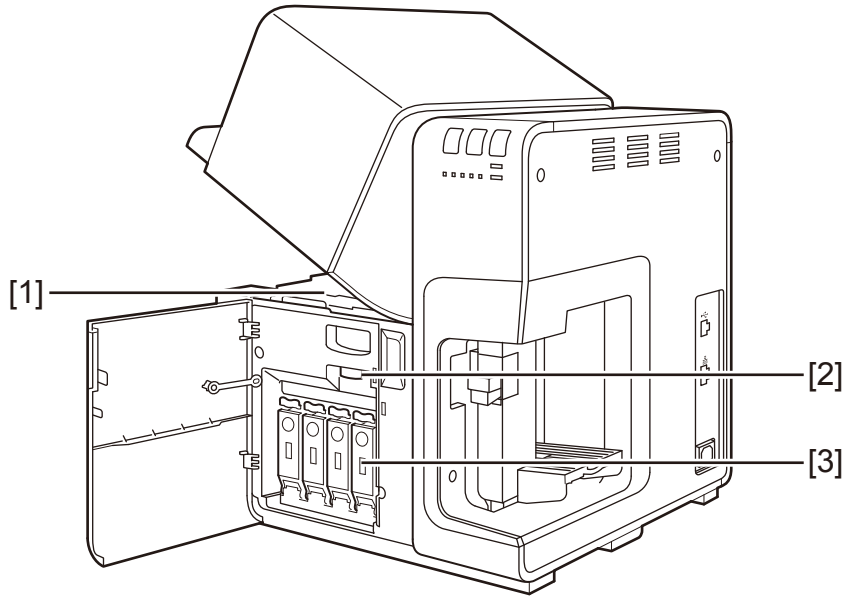

[1] **Transport area**

Transports paper. Clean here for paper dust and ink stains.

[2] **Upper unit open lever**

Use this lever to open the upper unit.

[3] **Ink tank cover**

Open it, there is Ink Tank inside.

1-1-4. Operation Panel

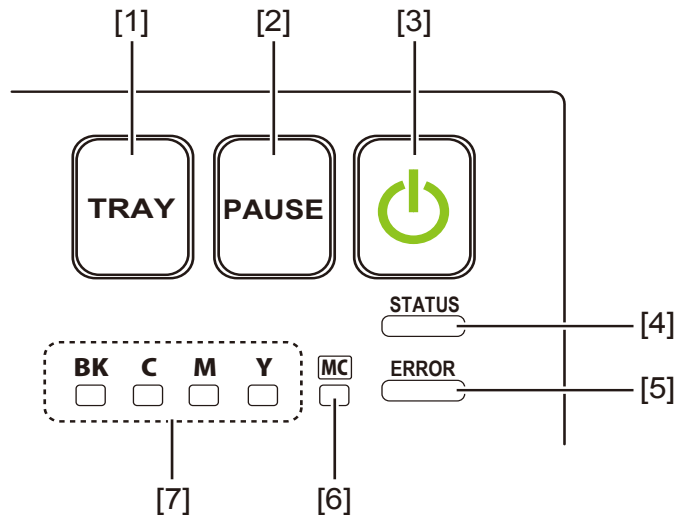

[1] TRAY key

Use this key to move the feeder tray upward/downward.

[2] PAUSE key

Printing	Pressing this key suspends printing.
in pause	Pressing this key restarts printing.

[3] Power key/lamp

On	Power-on.
Blinking	Sleep mode.
Off	Power-off.

[4] STATUS lamp

On	Online mode.
Blinking	Data being received (Please confirm a status monitor.).
Off	Offline mode (Please confirm a status monitor.).

[5] ERROR lamp

On	Operator-call error (Please confirm a status monitor.).
----	---

1. Before Using the Printer

Blinking	Fatal error.(Please confirm a status monitor.)
Off	Normal.(Please confirm a status monitor.)

[6] Maintenance Cartridge Warning lamp

On	Full.
Blinking	Nearly full.
Off	Sufficient room to collect ink.

[7] Ink warning lamp

On	No ink or tank.
Blinking	Low ink.
Off	Sufficient ink.

Important

- Opening the ink tank door or maintenance cartridge door during printing causes an error and suspends printing. This could result in a failure. Do not open the ink tank door or maintenance cartridge door except when replacing an ink tank or maintenance cartridge or opening/closing the upper unit.
- Never attempt to open the upper unit by force or hit the door. This could damage the printer or result in poor print quality. Always open and close the upper unit slowly.

1-1-5. Online and Sleep Modes

Online mode: This mode can print data from the computer. The STATUS lamp stays lit.

Sleep mode : Power lamp is blinking and the STATUS lamp stays unlit but the printer receives instructions and print data from the computer.

When print data is received, the printer is automatically placed in the online status to start printing.

Status of the printer	Receive data	Power Lamp	Status Lamp
Online	Printable	Lighting	Lighting
Sleep	Printable	Blinking	OFF

1-2 Connecting the Printer and Computer

The printer is compatible with Hi-Speed USB and LAN.

Important

- You can disconnect the USB cable even while the printer and computer are on, but do not disconnect the USB cable in the cases described below. This could prevent the printer from operating normally.
 - While the computer is starting up (until the desktop display appears).
 - While the printer is printing.
 - While you install the printer driver.

To disconnect the USB cable while the computer and the printer are on, disconnect it at the computer or the USB hub. To reconnect the USB cable, wait at least 5 seconds before you connect it again. If you reconnect it immediately, the printer may not operate correctly.

Note

- A USB cable is not provided with the printer. Please prepare a cable that matches the port on your computer.

1-2-1. Connecting with USB Cable

1

Connect the USB cable to the printer and the computer.

First, connect the cable to the printer, then connect it to the computer.

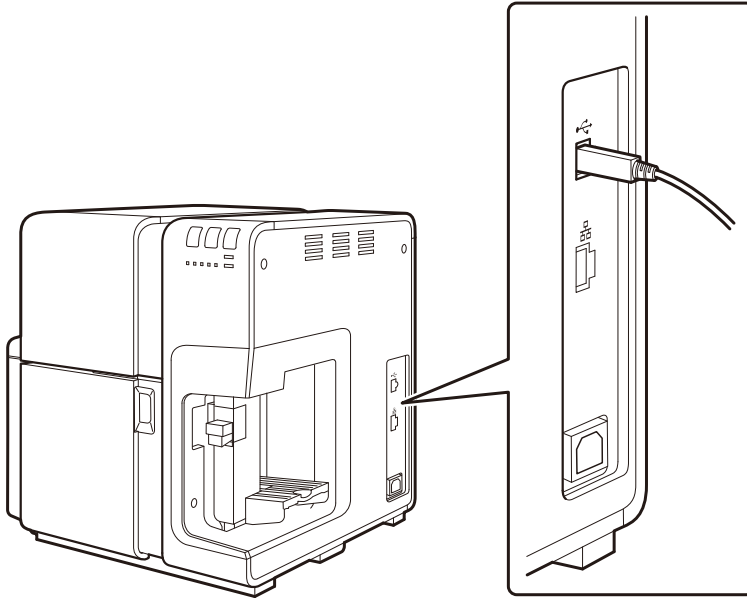

Note

- If a printer driver has not been installed in the computer to which you want to connect your printer, install it before connecting the USB cable.
- For how to install the printer driver, refer to the Start Guide.

1-2-2. Connecting with LAN Cable

1

Connect the printer to the network (TCP/IP) using a LAN cable.

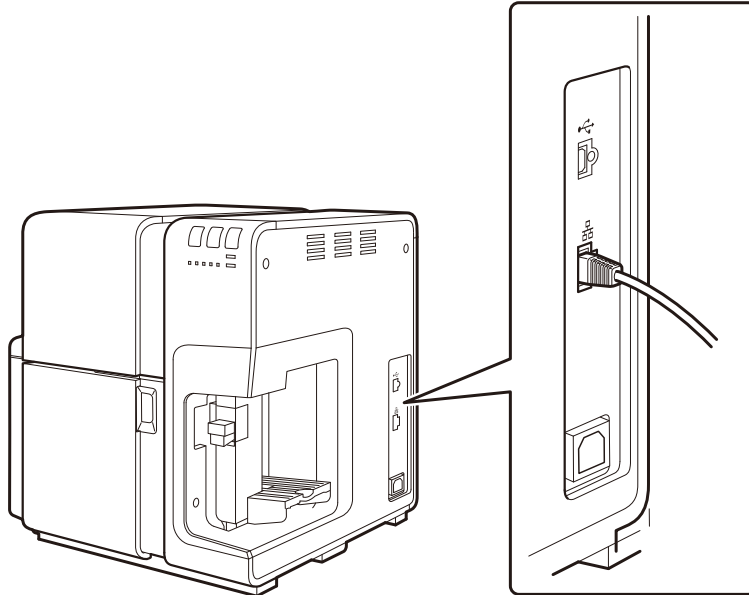

Note

- Use a category 5 twisted pair cable.
- Please consult your network administrator when connecting to an office LAN.
- If a printer driver has not been installed in the computer to which you want to connect your printer, install it before connecting the USB cable or LAN cable.
- For how to install the printer driver and connect the printer to the network, refer to the included start guide.

1-3 Switching the Printer On and Off

This section explains how to switch the printer on and off.

1-3-1. Switching the Printer On

Make sure that the power cable is connected properly, and then turn on the printer.

1

Press the Power key for at least 1 second.

Cleaning is performed and the printer becomes ready for printing.
When the printer is in the Online mode, the STATUS lamp stays lit.

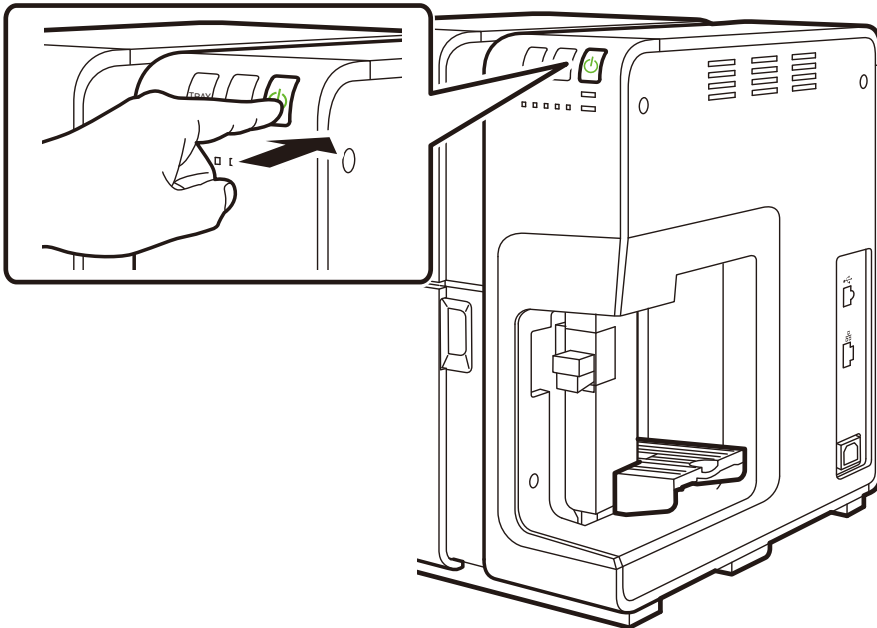

Note

- When the printer is in the sleep mode, press the power key to return the printer to online mode. Printer will also wake up from the sleep mode automatically as soon as it starts receiving a print job.

1-3-2. Switching the Printer Off

1

Press the Power key for at least 1 second.

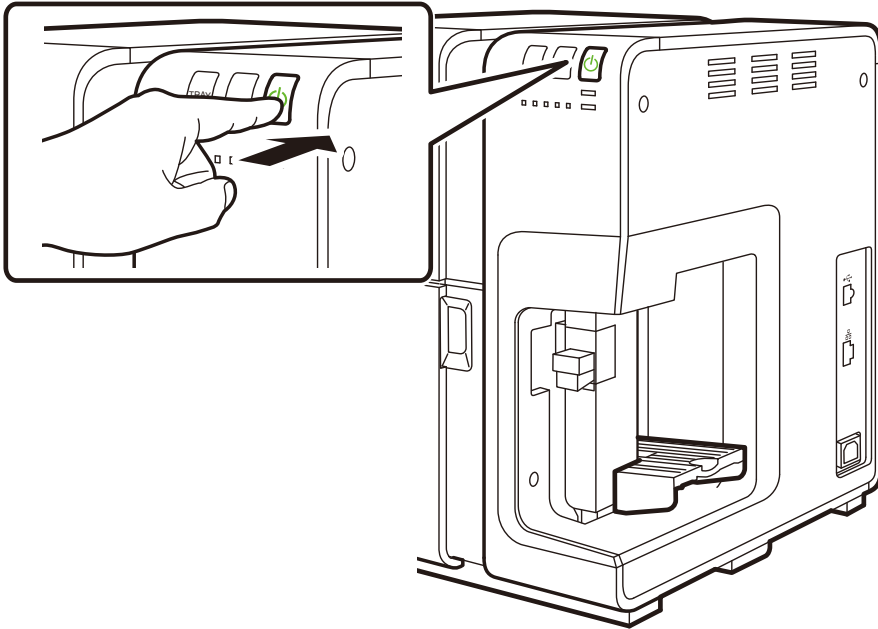

The Power lamp blinks at long intervals, and then the printer is turned off.

Note

- The Sleep mode can automatically be switched to the power-off state when a predetermined period of time has elapsed without printing.

→ [3-7-2. Sleep Timer Setting \(P.96\)](#)

Important

- When the printer is not used for a long period of time.
 - To prevent paper from discoloring, remove it from the feeder tray. Store the removed paper in a plastic bag or box such that it is not exposed to high temperature, high humidity, and direct sunlight.
 - Disconnect the power cable and interface cable from the printer.

1-4 Paper Loading Procedure

This section describes how to load paper.

Note

- It is recommended that paper exclusively for the color card printer be used. Using nonexclusive paper can cause bled and blurred printing or adversely impact the printer, resulting in troubles.
- When loading paper, check that top surface of the paper stack is not higher than the load limit mark.

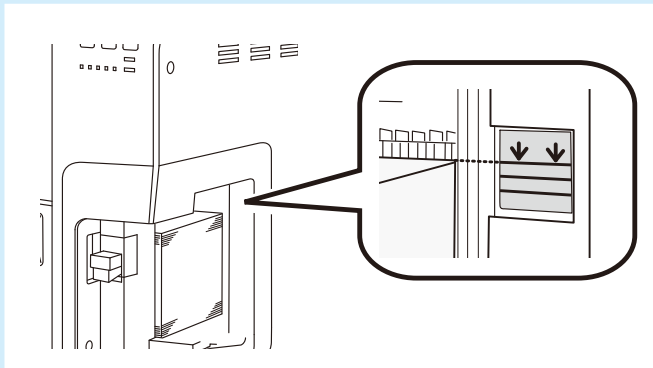

1

Make sure that the power lamp stays lit.

If the power lamp does not stay lit or it is not blinking, press the power key to put the printer in the power-on state.

2

While raising the side guide lever, move the side guide fully toward you.

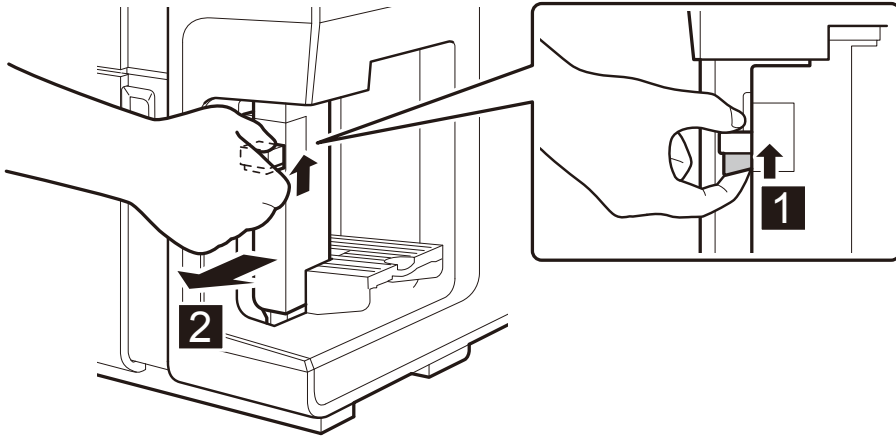

3

Load the paper in the feeder tray.

Load papers all the way into the point edges of sheets of paper are aligned.

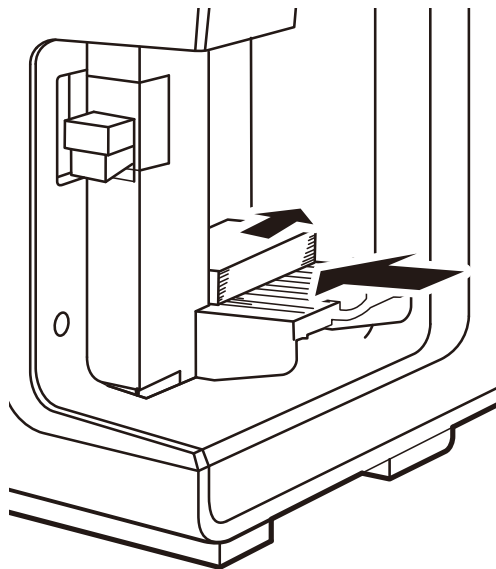

→ Paper Feed Direction and Image Orientation (P.29)

1. Before Using the Printer

Note

- When loading new paper, flap sheets of paper well and align all edges of sheets of paper.

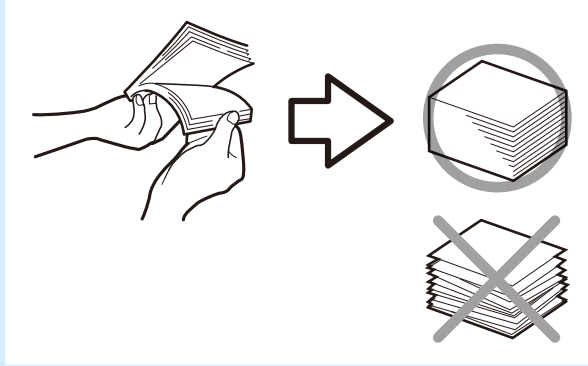

Important

- Do not print on the back of the envelope. A printing failure or other problems may result.

Note

- When loading envelopes, pull out the auxiliary tray.

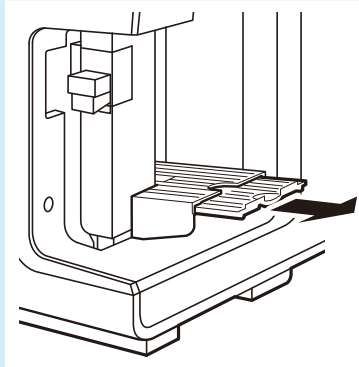

- Load envelopes with their outsides (on which an address is printed) up, in such a manner that the sealing portions are closed and pressed against the side guide (rear).

→ Paper Feed Direction and Image Orientation (P.29)

- If sheets of new paper or swelled envelopes are loaded as they are, they may not be fed smoothly. When loading sheets of new paper, flap them well and press on swelled envelopes before loading them.



- Flatten curled sheets of paper before loading them.
- The capacity of the feeder lift tray is as follows:
 Business Card/ Postcard : 500 sheets (Thickness: 0.245mm or less)
 Special heavy paper (Card) : 100 sheets (Thickness: 0.76 mm)
 Envelope : 100 sheets

When loading paper, check that top surface of the paper stack is not higher than the load limit mark. If a paper feed error occurs, reduce the number of sheets loaded in the tray.

4

While raising the side guide lever, slowly move the side guide until it stops against paper.

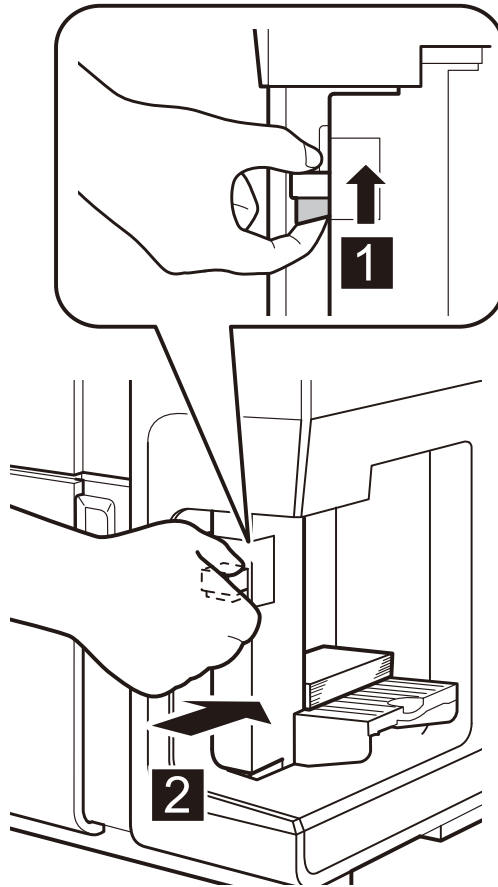

Important

- Do not press the side guide against the paper stack too strongly. A paper jam can result.

5

Press the TRAY key.

The feeder lift tray rises automatically. Wait until it stops rising.

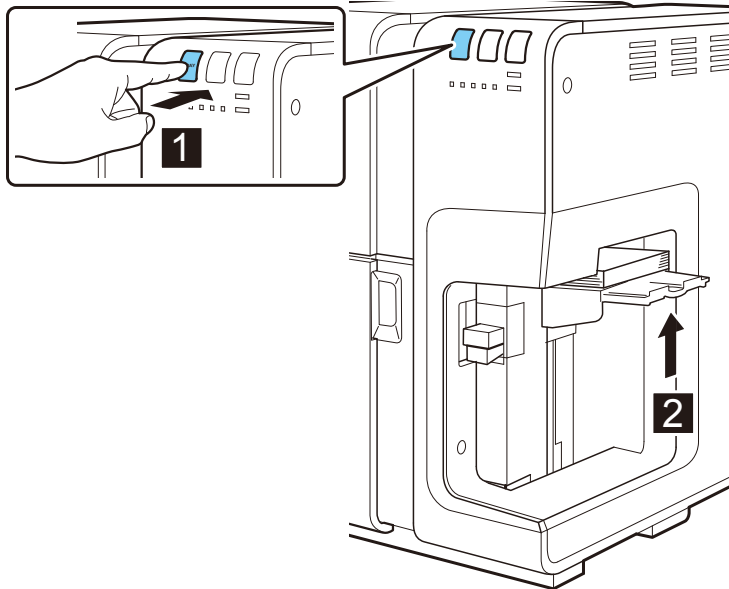

Important

- When the feeder lift tray is operating, do not touch it. A failure can result.

6

When the status lamp stays lit in green, the printer is ready for printing.

Note

- When an high-density image is printed or glossy paper is used, the edges of sheets of paper stacked in the auto stacker may not be aligned properly resulting in a paper jam. It is recommended that the printed sheets of paper are frequently removed from the auto stacker.
- If paper is not loaded properly, the error lamp lights and an error message is displayed on the Status Monitor window. Retry loading paper.

1. Before Using the Printer

Important

- When storing paper, put it in a plastic bag and keep it in a place not exposed to direct sunlight or fluorescent light to prevent discoloration, etc. Once you open the package of paper, it is recommended to use the paper as soon as possible.
- Check that the paper size of the actually loaded paper is the same as that selected by the printer driver.
- Do not operate the side guide after the feeder lift tray has risen. It may cause a paper jam.

Important

■ **To those who use thick paper**

To use thick paper, set [Paper form] of the printer driver to [Thick paper] and, pull out the thick paper transport lever in the paper delivery slot.

● **Setting the printer driver**

On the Page Setup sheet, set [Paper form] to [Thick paper].

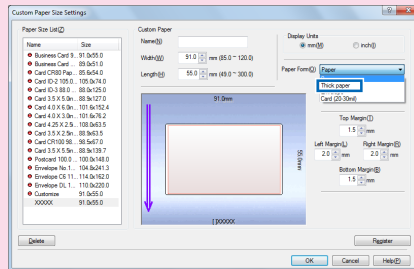

● **Setting the thick paper transport lever**

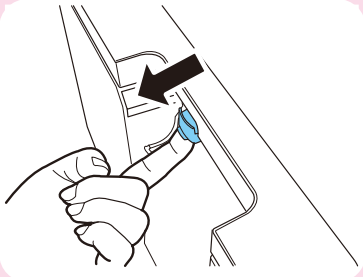
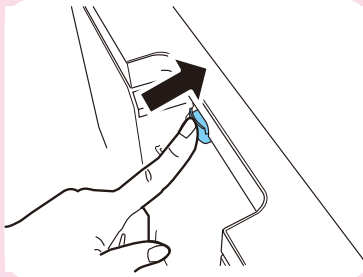
When using thick paper	When using paper other than thick paper
Pull out the thick paper transport lever in the paper delivery slot.	Push the thick paper transport lever in the paper delivery slot.
	

*Settings for both the printer driver and thick paper transport lever are required. If these are not set properly, an error message is displayed on the Status Monitor window and the printer does not operate.

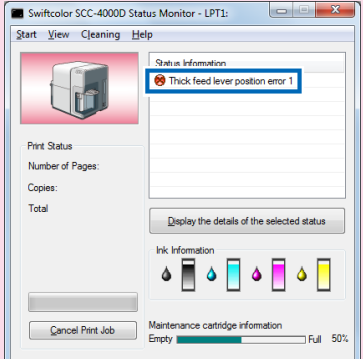
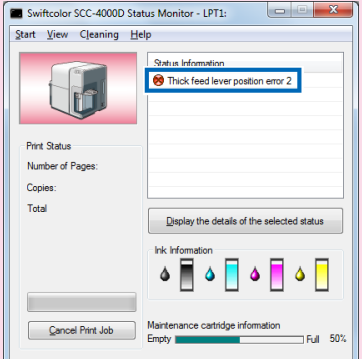
When the thick paper transport lever is not pulled out	When [Special heavy paper] is not set by the printer driver
	

1-5 For the use of Plastic Card

Please follow the following procedure for the plastic card printing.
Make sure that printer is switched off.

- 1 Press the power key for at least 1 second.
Auto Stacker lowers automatically.

- 2 Load Additional tray to the auto stacker.
Set Additional Tray to Auto Stacker. Push it until it reaches the end.

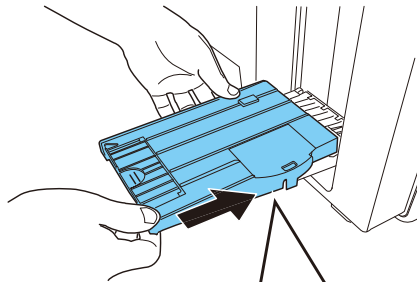

Make sure that the bottom part (marked in red) of Additional Tray and Auto Stacker should be located in parallel as shown in figure.

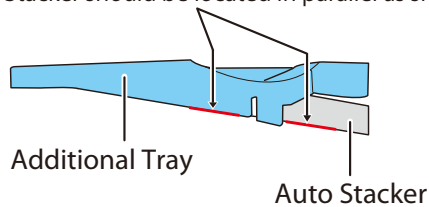

Note

- When loading 3.5×5.5inch Plastic card, stand the flap of additional tray.

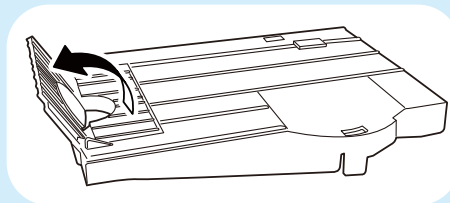

Note

- When remove Additional Tray, pull and down it as shown in figure.

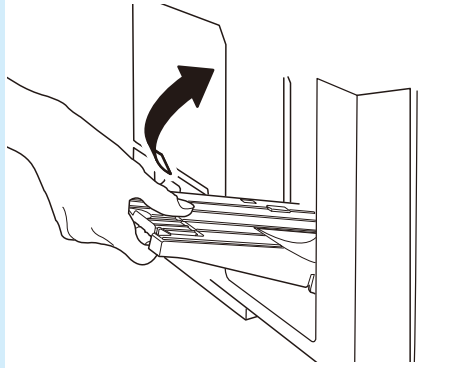

3

Turn on the printer.

Press the power key.

4

Press down Feeder tray lever to [Plastic].

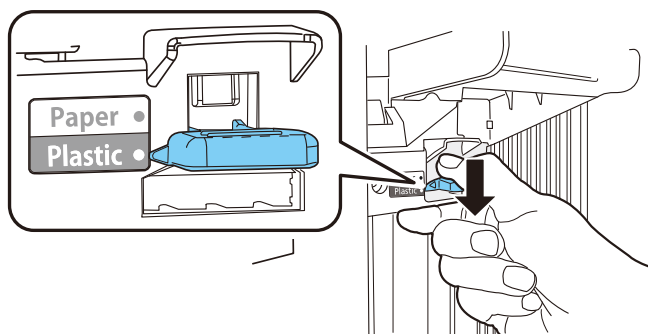

1. Before Using the Printer

Note

- When loading paper media, set Feeder tray lever to [Paper].

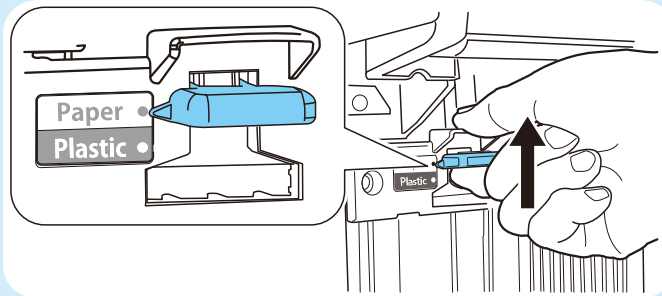

5

Open the [Page Setup] sheet in Printer driver and select [Plastic Card] for [Paper Type].

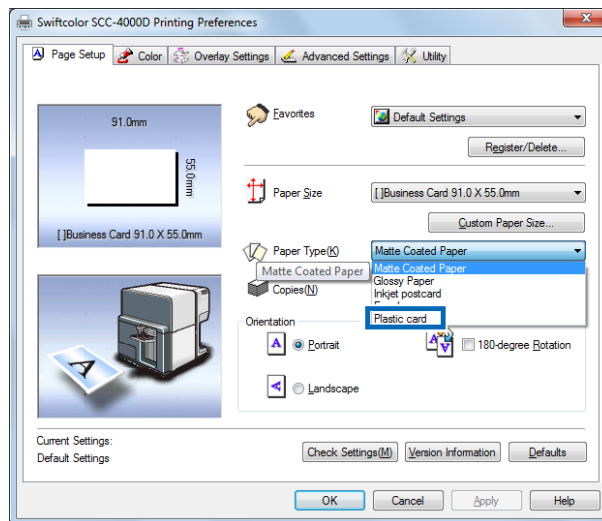

6

Press TRAY key.

The feeder lift tray lowers automatically.

Wait until it stops lowering, and then set the plastic card.

→ 1-4 Paper Loading Procedure (P.16)

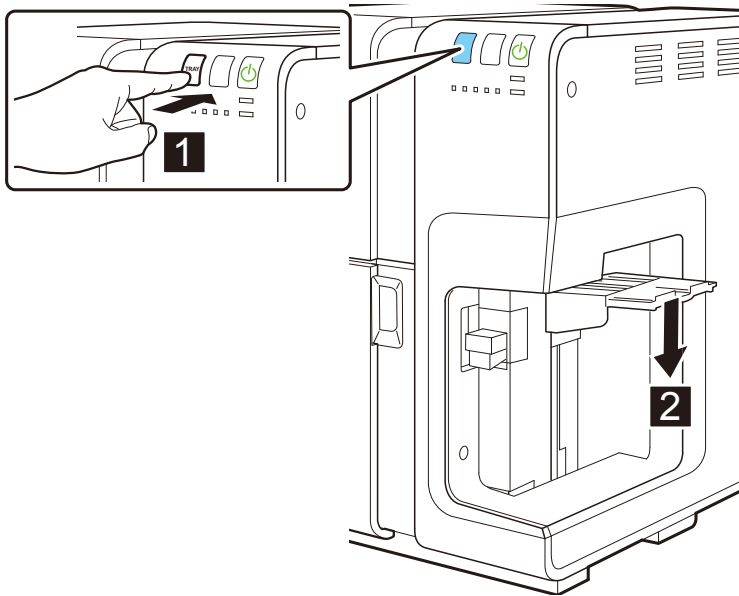

1. Before Using the Printer

Important

■ To those who use plastic card

To use thick paper or plastic card, set [Page setup] of the printer driver to [Card CR80 plastic 85.6x54.0mm][Card 4.25 x 2.5inch][Card 3.5 x 2.5inch] and, pull out the thick paper transport lever at the paper delivery slot.

● Setting the printer driver

On the Page Setup sheet, set [Paper Size] and [Paper Type] to [Plastic card].

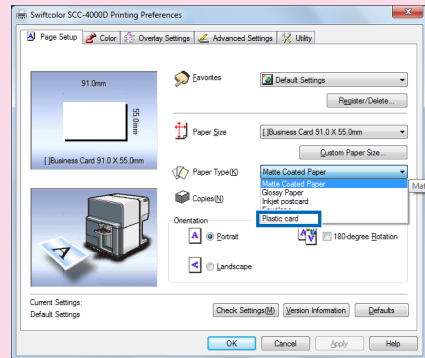
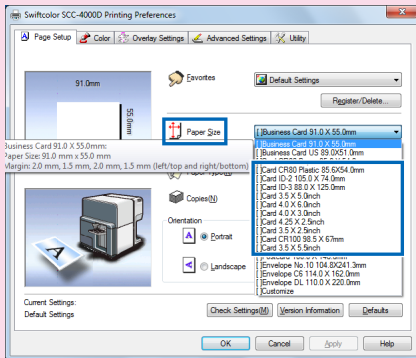

● Setting the thick paper transport lever

- When using plastic card (Paper length is less than 57mm)
 - [Card CR80 plastic 85.6x54.0mm]
 - [Card 4.25 x 2.5inch]
 - [Card 3.5 x 2.5inch]

- When using plastic card (Paper length is 57mm or more)
 - [Card ID-2 105.0 x 74.0mm]
 - [Card ID-3 88.0 x 125.0mm]
 - [Card 3.5 x 5.0inch]
 - [Card 4.0 x 6.0inch]
 - [Card 4.0 x 3.0inch]
 - [Card CR100 98.5 x 67mm]
 - [Card 3.5 x 5.5inch]

Pull out the thick paper transport lever in the paper delivery slot.

Push the thick paper transport lever in the paper delivery slot.

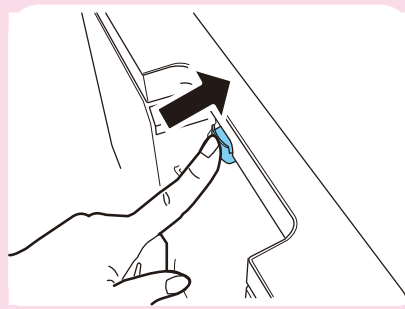
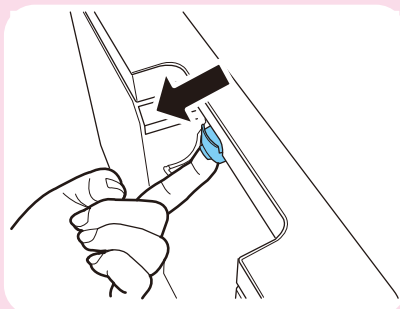

*Settings for both printer driver and thick paper transport lever are required. If these are not set properly, an error message is displayed on the Status Monitor window and the printer does not operate.

■ Paper Feed Direction and Image Orientation

On this printer, paper is fed from the feeder lift tray located at the right and ejected to the auto stacker located at the left. Note that the paper loading direction and image orientation differ depending on the type of paper. Image orientation can be set on the [Page Setup] sheet in the [Printing Preferences] dialog box of the printer driver.

→ 3-2-7.Orientation (P.62)

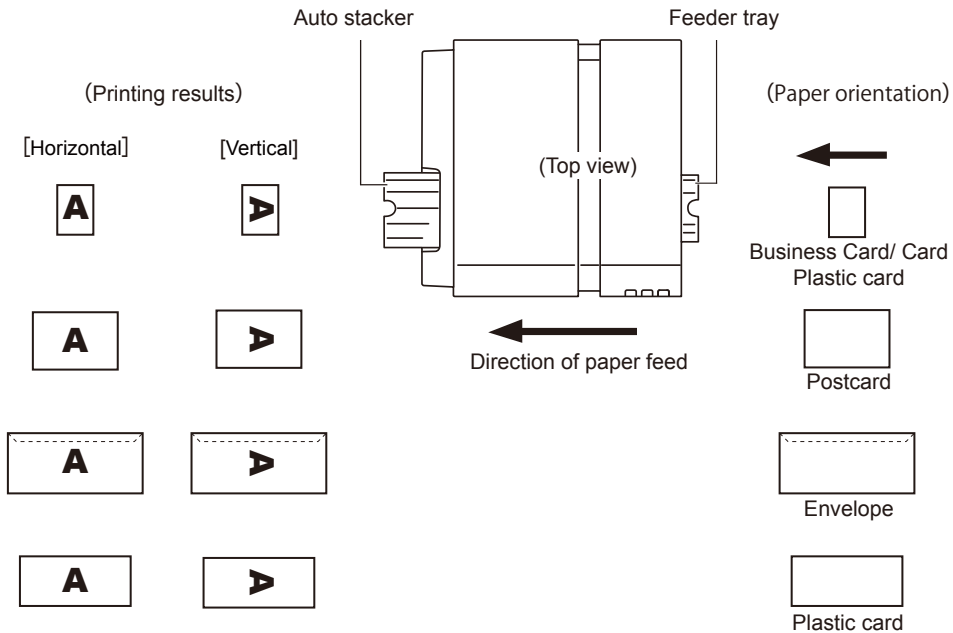

Note

- The set print orientation is shown in the preview window on the [Page Setup] sheet.
- Some types of application software determines the print orientation on its own accord. Be sure to carry out test printing to confirm the print orientation. For more details, refer to the documentation supplied with your application software.

2. How to Print

When the printer is ready to print, create documents using various kinds of application software and print them.

2-1 How to Make of Print Data

When a document is created, start printing from the application software.

Important

- Keep the printer free from vibration or impact while it prints. Paper jams or printing failures might result.

Note

- The printing procedures, Windows button names and so on may differ depending on your application software. Refer to the documentation supplied with your application software as well.
- In printing, set the Windows system standby or the sleep mode setting to “No.” To set this option, select [Control Panel] from the [Start] menu of Windows and select [Power Options] to open the [Power Options Properties] window.

1

Open the [File] menu in the application software, and then click [Print].

“Print” dialog box appears.

2

Check that [Swiftcolor SCC-4000D] has been selected in [Printer Setup].

If any other printer name is displayed, select [Swiftcolor SCC-4000D] in [Printer Setup].

Note

- If your application software supports buttons designed to configure a printer (such as [Advanced Settings] and [Properties]), set the paper type, colors and so on here.

3

Specify the number of copies to print.

The number of copies specified here overrides its setting in the [Print Setup] dialog box for the printer driver.

4

Check that paper is ready, and then click [Print].

Printing starts.

Note

- See “How to Use the Printer Driver” to modify print setting to suit specific purposes.
→ [3. How to Use the Printer Driver \(P.39\)](#)
- If the application software and the printer driver share the same setup items, such as paper size, print orientation and number of copies, the settings of the application software may govern.
- The print settings that have been configured in an application software are used only for the application. Print settings that are commonly used for various kinds of application software must be configured from [Control Panel] in Windows.

2-2 Canceling Print Jobs

Cancel a print job that has been initiated from the computer.

2-2-1. Canceling Print Jobs from the Status Monitor

The print job can be canceled by clicking [Cancel Print] in the status monitor.

- Click [Cancel Print job] in the [Swiftcolor SCC-4000D Status Monitor] window.

The print job is canceled, and the currently printing job and the jobs that are under processing or receiving data in the printer are also abandoned, along with all print data in process in the computer.

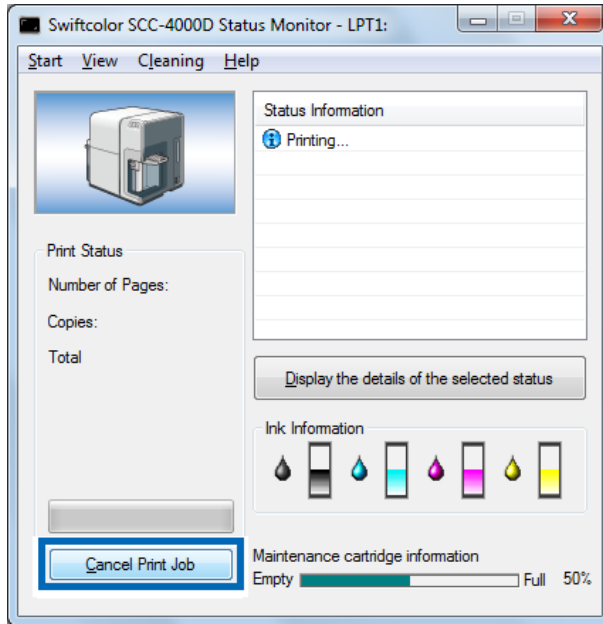

Note

- If the “Status Monitor” window is not displayed, it should either be minimized in the taskbar or placed in the task tray. Click the taskbar or task tray to open the “Status Monitor” window.
→ [4-1 Displaying the Status Monitor \(P.119\)](#)
- A print job can be canceled in the “Print Queue” window (the window in which the order of print jobs is registered), as well as in the “Status Monitor” window. For more information, refer to the Windows documentation.

2-3 Pausing Printing

The pause function is described below.

Printing can be paused by pressing the [PAUSE] key on the operation panel.

2-3-1. Pause from the Operation Panel

Use this function to view the status of printing in progress or perform cleaning.

1

Press the [PAUSE] key on the operation panel while printing is in progress.

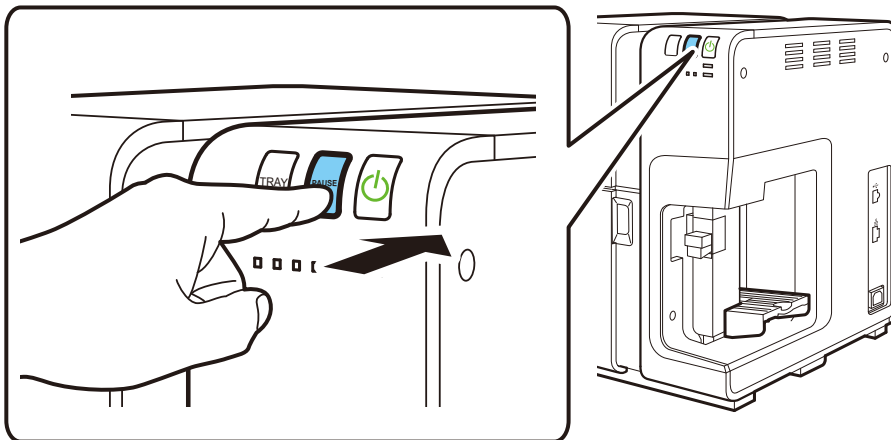

2

The printer pauses.

Press the [PAUSE] key again to release the printer from the pause and resume printing at the point of interruption.

2-3-2.Cleaning During Pause Stop

Important

- Cleaning from the “Status Monitor” window is enabled only while the printer pauses.
- The [Utilities] sheet is not available while the printer pauses.

1

Cleaning can be performed while the printer pauses. Click the [Cleaning] menu in the “Status Monitor” window and select ”Light Cleaning”, “Medium Cleaning” or “Strong Cleaning”select.

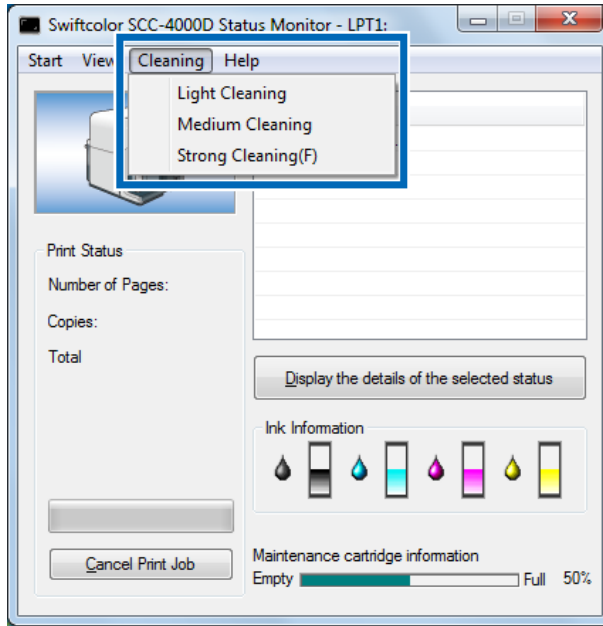

Clean the ink nozzles to prevent them from clogging.
Perform cleaning by selecting ”Light Cleaning”, “Medium Cleaning” or “Strong Cleaning” in considering the print results.

Light Cleaning	Recovery operation performed first when printhead nozzle clogging occurs. (Repeat this operation as required.)
Medium Cleaning	Recovery operation performed when printhead nozzle clogging occurs even after light cleaning is performed. (Repeat this operation as required.)
Strong Cleaning	Recovery operation performed when printhead nozzle clogging occurs even after Medium cleaning is performed. (Repeat this operation as required.)

Important

- While cleaning is in progress, do not perform any other operation.
- Cleaning cannot be done during a print job or when an error is occurring.
- If Strong cleaning fails to solve the problem, the printhead may require replacement, or there could be some other problem. Follow the troubleshooting procedure and if the problem is not solved after it, contact dealer.
- Please remember that cleaning consumes ink. Clean the printhead only when necessary.

3. How to Use the Printer Driver

This section describes the function of the each item in the printer driver dialog box.

3-1 Opening the Printing Preferences Dialog Box

Open the [Printing Preferences] dialog box for the printer driver to configure various print functions. The [Printing Preferences] dialog box can be opened in two ways: open it from application software and from the [Start] menu in Windows.

Note

- The print settings that are set in the [Properties] dialog box opened from application software are only used for that application software.
- Set the print settings that are commonly used for various kinds of application software from the [Start] menu in Windows.

→ [3-1-2. Opening from the Start Menu \(P.41\)](#) [3-1-2. Opening from the Start Menu \(P.41\)](#)

3-1-1. Opening from the Application Software

To open [Printing Preferences] from the application software in use, select [Print] and then [Properties].

- 1** Open the [File] menu in the application software, and click [Print...].
- 2** Select [Swiftcolor SCC-4000D] in [Printer Name] and click [Properties].

3

[Swiftcolor SCC-4000D Printing Preferences] window appears.

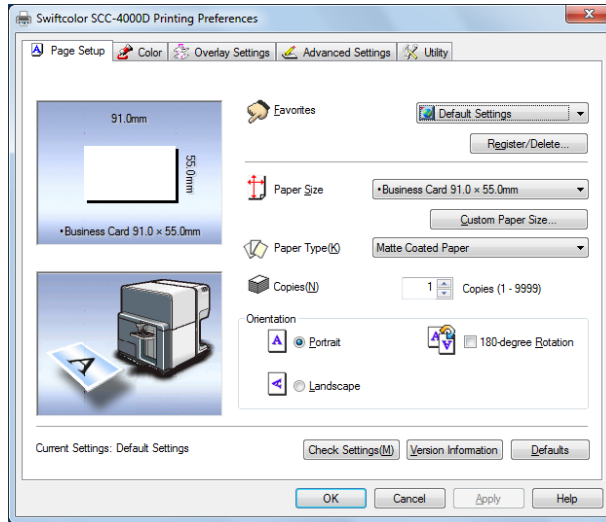

Note

- The method of opening the [Properties] dialog box varies with the kind of application software. For more information, refer to the instruction manual supplied with your application software.
- The [Printing Preferences] dialog box, when opened from the application software, contains the [Utility] tab. Click this tab to open the Utility sheet in which cleaning such as Printhead cleaning can be performed.
- The [Utility] sheet that is opened from the [Printing Preferences] dialog box and the [Utility] sheet that is opened from the [Printer Properties] dialog box differ in the repertoire of items that can be set.

→ 3-7 Using the Utility Dialog box (P.91)

3-1-2. Opening from the Start Menu

To set up print, open the [Printing Preferences] or [Printer Properties] dialog box from the [Start] menu in Windows.

Use this option to register common settings, regardless of the kind of application software used.

1

Click [Start] and then click [Devices and Printers].

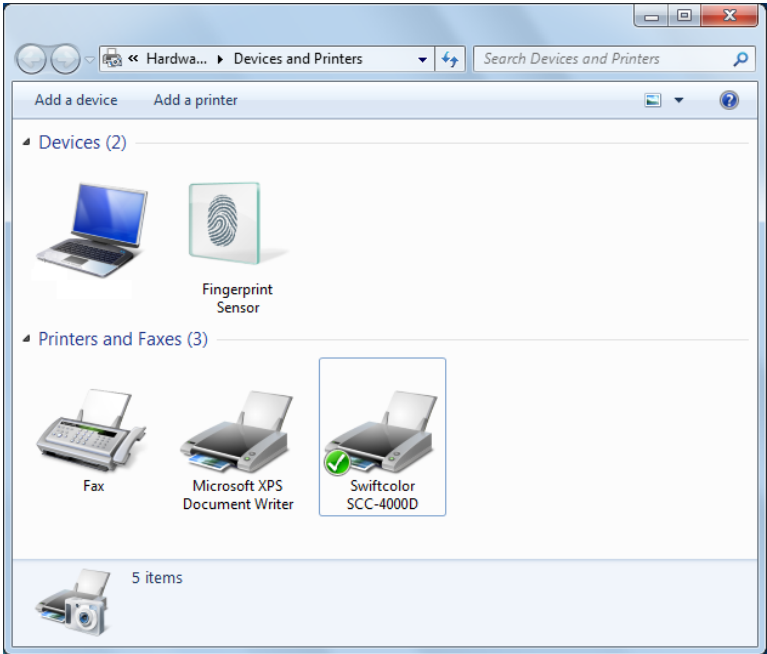

Note

- With Windows Vista, click [Start] and select [Printers] from [Hardware and Sound] in [Control Panel].
- With Windows XP, click [Start] and select [Printer and FAX].

2

Right-click on the [Swiftcolor SCC-4000D] Printer icon and select [Printing Preferences].

[Swiftcolor SCC-4000D Printing Preferences] dialog box appears.

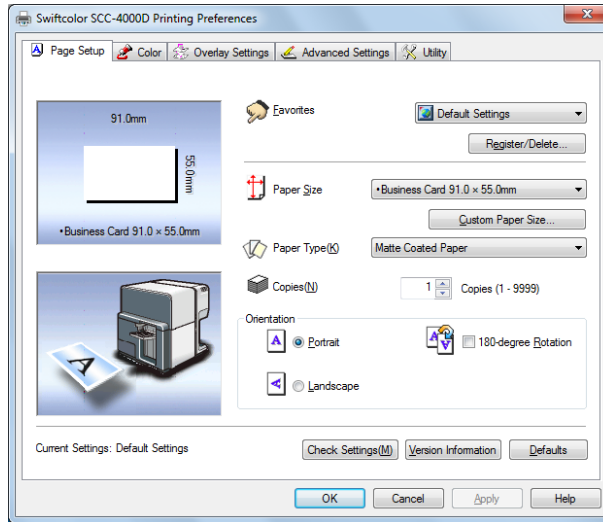

Note

- The [Printing Preferences] dialog box can also be opened by clicking [Preferences] in the [Swiftcolor SCC-4000D Properties] dialog box.

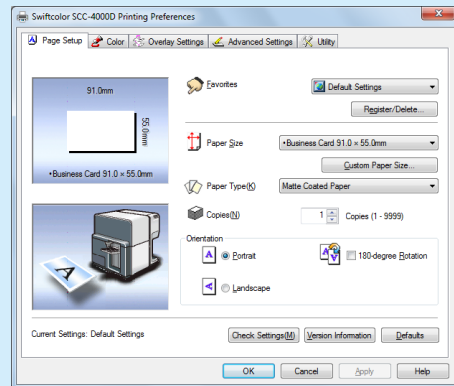
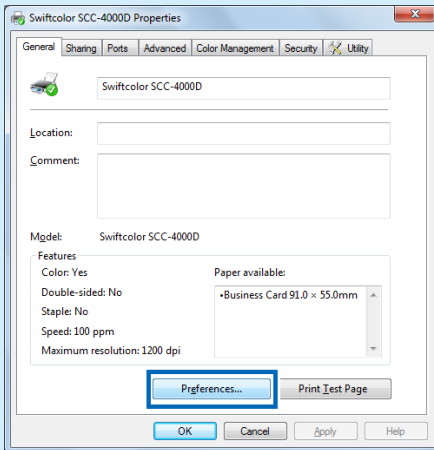

3-2 Using the Page Setup Dialog Box

The [Page Setup] sheet is described below.

The [Page Setup] sheet in the [Printing Preferences] dialog box allows you to set paper settings, such as the number of copies to print and the orientation of printing.

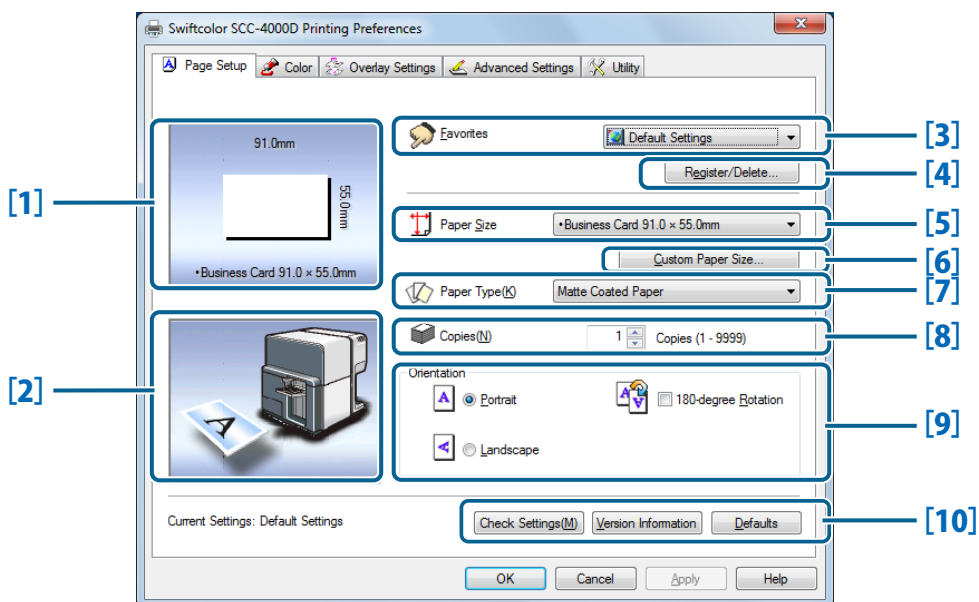

[1] Paper Size Preview

The currently set paper size is displayed in a preview.

[2] Print Orientation Preview

The currently set paper orientation for printing is displayed in a preview.

[3] Favorites

Register commonly used print settings.

→ [3-2-3. Using Print Setting Registered in Favorite \(P.51\)](#)

[4] Register/Delete

Register or delete Favorites.

→ [3-2-1. Registration of Favorites \(P.45\)](#)

→ [3-2-2. Deletion of Favorites \(P.48\)](#)

[5] Paper Size

Set a paper size.

→ [3-2-4. Paper Size \(P.53\)](#)

3. How to Use the Printer Driver

[6] Custom Paper Size

Set an optional paper size.

→ [3-2-5. Custom Paper Size Settings \(P.56\)](#)

[7] Paper Type

Set a paper type.

→ [3-2-6.Paper Type \(P.61\)](#)

[8] Copies

Set the number of copies to print.

[9] Orientation

Set the orientation of printing on the paper.

→ [3-2-7.Orientation \(P.62\)](#)

[10] Check Settings

Displays the current print settings.

→ [3-2-8.Check Settings \(P.64\)](#)

Version Information

Displays version information on the printer driver and the information about the currently connected printer.

→ [3-2-9.Version Information \(P.65\)](#)

Defaults

Reset the [Page Setup] sheet to its defaults.

Note

- If [Printer Properties] has been opened from application software, the settings cannot be registered or deleted. To register or delete settings, open the [Print Setup] dialog box from the [Start] menu in Windows.

→ [3-1-2. Opening from the Start Menu \(P.41\)](#)

3-2-1. Registration of Favorites

Up to 10 Favorites can be registered. Favorites, once registered, are imported by simply selecting them from a list, so that print jobs can always be executed with the same set of print settings.

Note

- If [Printer Properties] has been opened from application software, the settings cannot be registered or deleted. To register or delete settings, open the [Printing Preferences] dialog box from the [Start] menu in Windows.

→ 3-1-2. Opening from the Start Menu (P.41)

1

Set the data to be registered in the [Page Setup] sheet, [Color] sheet and [Advanced Settings] sheet.

Click the [Page Setup] tab, the [Color] tab and the [Advanced Settings] tab to open the respective sheets for setup.

Note

- If a paper size different from the default size needs to be registered in the [Page Setup] sheet, set the desired paper size at user paper setup and have registered beforehand.

→ 3-2-5. Custom Paper Size Settings (P.56)

2

The [Page Setup] sheet appears again.

Check that [Current Settings] has been selected in [Favorites].

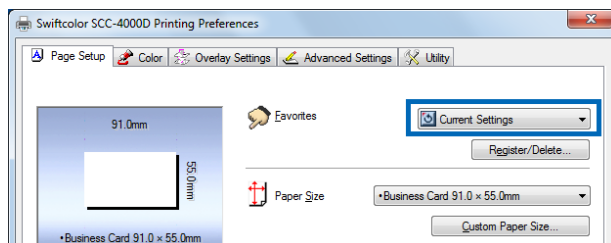

3 Click [Register/Delete].

The [Register and Delete Settings] dialog box appears.

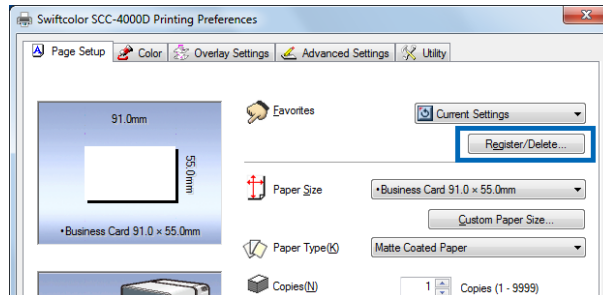

4 Type an optional name in the [Setting File Name] box and, on confirming [setting Contents], click [Register].

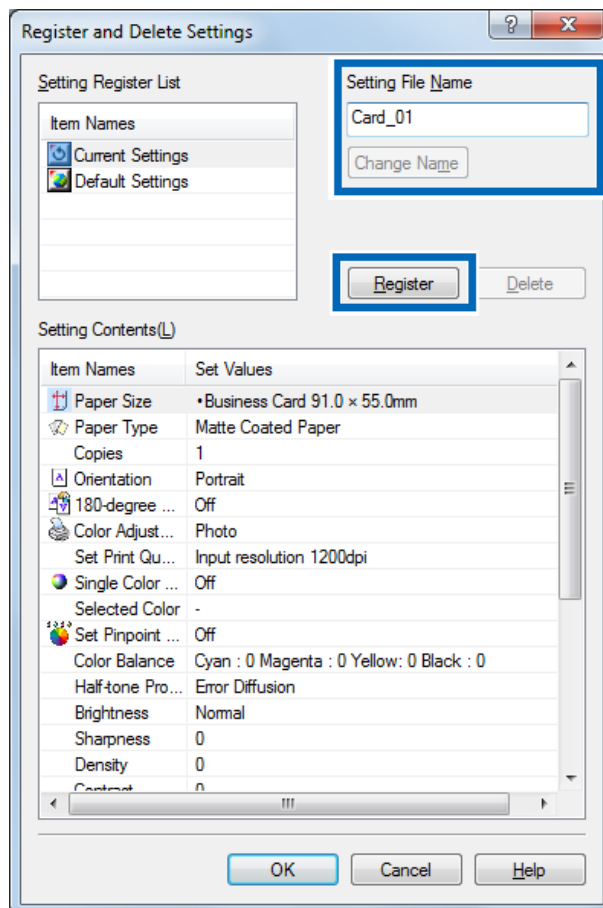

Note

- The entry of a name is required. Space and tab characters are not allowed in the name. The name can be up to 16 single- and double-byte characters long.
- New names cannot be registered at the position in [Current Settings] and [Default Settings]. A new entered name is added.

5 When the registration confirmation dialog box appears, click [Yes].

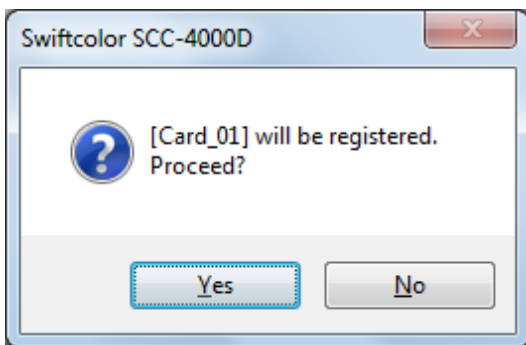

6 Confirm [Setting Contents] and click [OK].

7 Check that the registered name has been added in [Favorites].

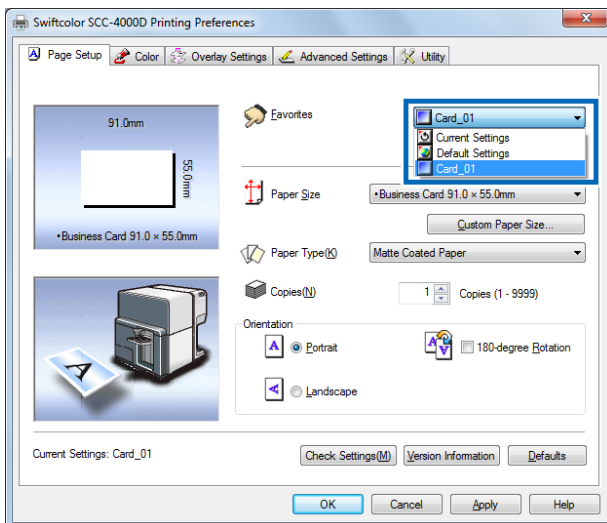

8

Click [Apply] and then click [OK].

The print setting is registered in [Favorites].

Note

- To rename registered print settings, select the name of an item to edit from [Favorites] and click [Register/Delete]. Rename the item in [Set Name] in the [Register and Delete Settings] dialog box and click [Register].

3-2-2. Deletion of Favorites

Delete the settings registered in [Favorites].

1

Click [Register/Delete] in [Favorites].

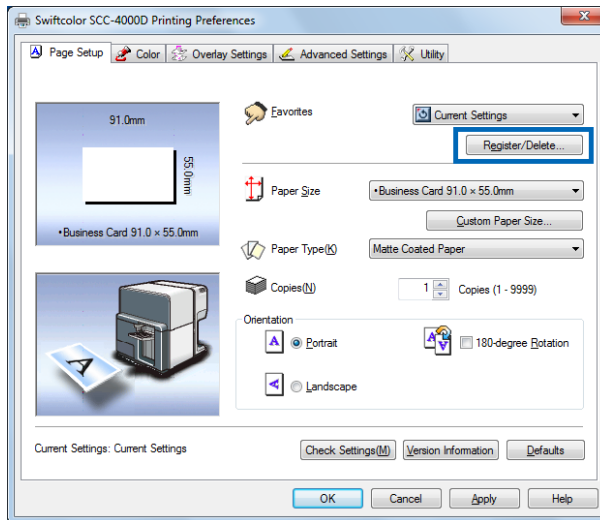

2

Select the setting to delete from the [Setting Register List] in the [Register and Delete Settings] dialog box and click [Delete].

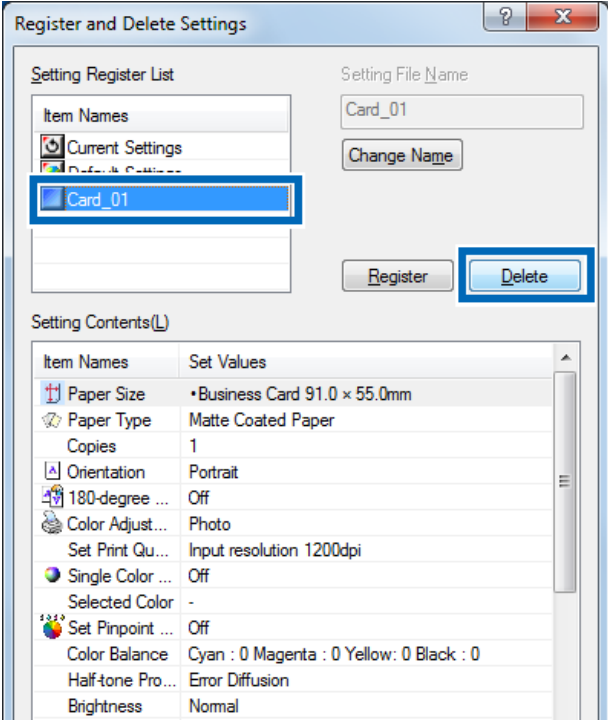

3

When the confirmation window opens, click [Yes].

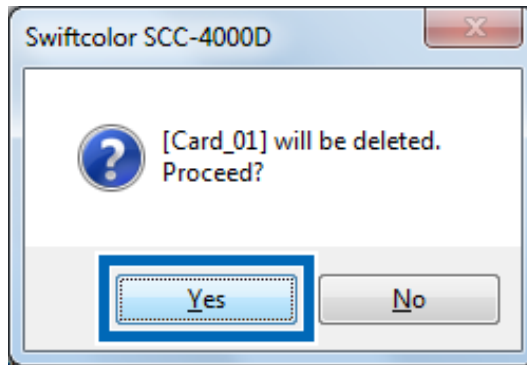

4

The registered setting is deleted from [Setting Register List].

Check that the print setting has been deleted and click [OK].

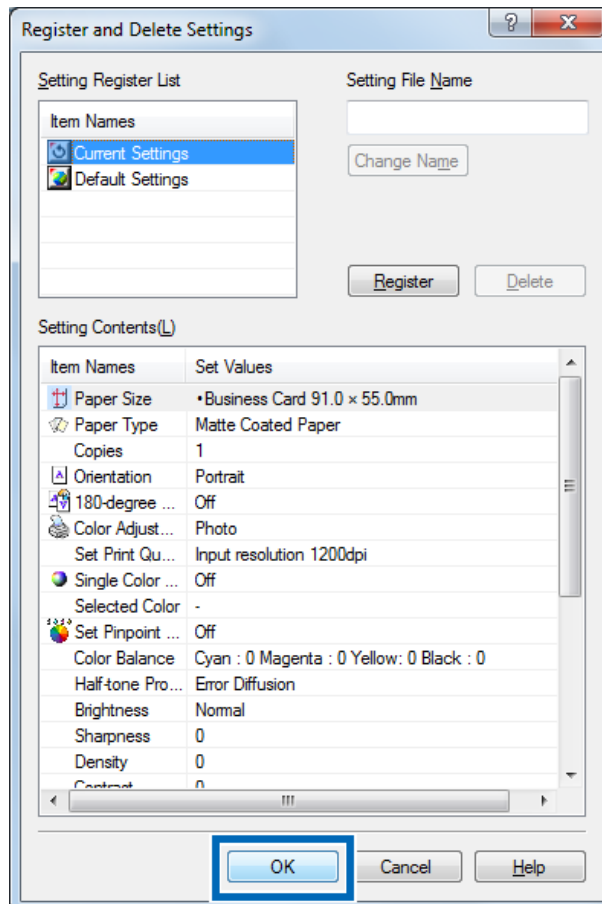

3-2-3. Using Print Setting Registered in Favorite

Printing can be performed using the print settings registered in [Favorites]. The print settings registered in [Favorites] are imported by simply selecting them from a list, so that print jobs can always be executed with a desired set of print settings.

1 Select the print settings to use from [Favorites] and click.

Imports print settings.

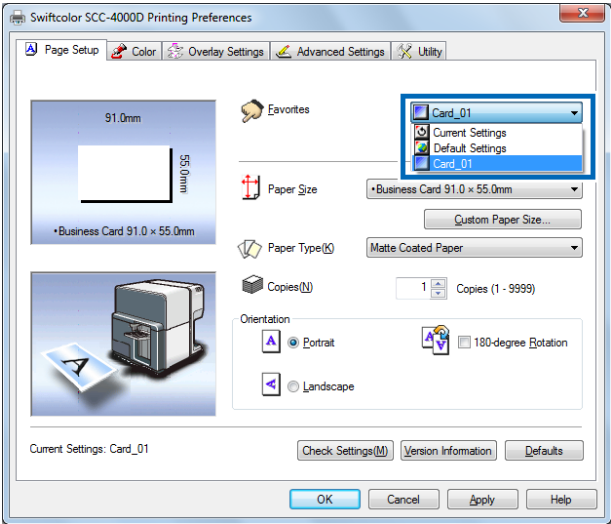

Note

- Click [Check Settings] to view the current print settings.
- Select [Default Settings] to reset the printer to the state in which it had been when the printer driver was installed (or the state in which no changes have been made to the settings).

3. How to Use the Printer Driver

- Default Settings

Sheet	Item	Settings
Page Setup	Favorites	Default settings
	Paper Size	Business Card 91.0 × 55.0 mm
	Paper Type	Matte Coated Paper
	Copies	1
	Orientation	Portrait
	180-degree	Off
Color	Color Adjustment	Photo
	Set Print Quality	Input resolution 1200dpi
	Single color Settings	Off
	Selected Color	-
	Pinpoint Color Matches	Off
	Color Balance*	Bk/C/M/Y All 0
	Half-tone Process*	Error Diffusion
	Brightness *	Normal
	Sharpness*	0 (None)
	Density *	0
	Contrast *	0
Overlay Settings	Level Correction*	Off
	Overlay	Off
	Print Mode	-
	Preview	-
	Comment	-
	Print the overlay with simple setting	-
Advanced Settings	Layout	None
	Frame Printing	Off
	Print Order	Ascend
	Paper feed interval	0 sec

*Items in the [Detailed Settings] dialog box.

3-2-4. Paper Size

1

In [Paper Size], select the size of paper on which to print.

[Paper Size] is selectable from the following choices:

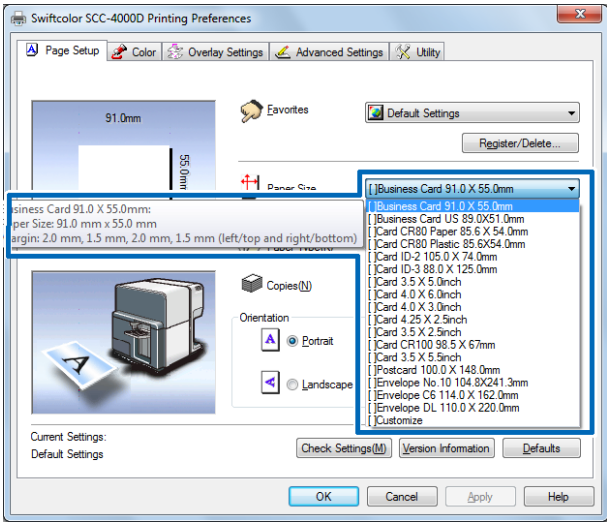

[Standard label paper]

Paper Size	Shape of Media	Paper Size (W×L) mm	Margins (mm)			
			Top Margin	Bottom Margin	Left Margin	Right Margin
Business Card 91.0 × 55.0mm	Card	91.0 × 55.0	1.5	1.5	2.0	2.0
Business Card US 89.0 × 51.0mm	Card	89.0 × 51.0	1.5	1.5	2.0	2.0
Card CR80 Paper 85.6 × 54.0mm	Card	85.6 × 54.0	1.5	1.5	2.0	2.0
Card CR80 Plastic 85.6 × 54.0mm	Card	85.6 × 54.0	1.5	1.5	2.0	2.0
Card ID-2 105.0 x 74.0mm	Card	105.0 x 74.0	1.5	1.5	2.0	2.0
Card ID-3 88.0 x 125.0mm	Card	88.0 x 125.0	1.5	1.5	2.0	2.0
Card 3.5 x 5.0inch	Card	88.9 x 127.0	1.5	1.5	2.0	2.0
Card 4.0 x 6.0inch	Card	101.6 x 152.4	1.5	1.5	2.0	2.0
Card 4.0 x 3.0inch	Card	101.6 x 76.2	1.5	1.5	2.0	2.0
Card 4.25 x 2.5inch	Card	108.0 x 63.5	1.5	1.5	2.0	2.0

3. How to Use the Printer Driver

Card 3.5 x 2.5inch	Card	88.9 x 63.5	1.5	1.5	2.0	2.0
Card CR100 98.5 x 67mm	Card	98.5 x 67.0	1.5	1.5	2.0	2.0
Card 3.5 x 5.5inch	Card	88.9 x 139.7	1.5	1.5	2.0	2.0
Postcard 100.0 × 148.0 mm	Postcard	100.0 × 148.0	1.5	1.5	2.0	2.0
Envelope No.10 104.8 × 241.3mm	Envelope	104.8 × 241.3	1.5	1.5	2.0	2.0
Envelope C6 114.0 × 162.0mm	Envelope	114.0 × 162.0	1.5	1.5	2.0	4.2
Envelope DL 110.0 × 220.0 mm	Envelope	110.0 × 220.0	1.5	1.5	2.0	2.0

*Seven standard paper sizes are registered in advance.

Note

- The current paper size can be identified in a preview.

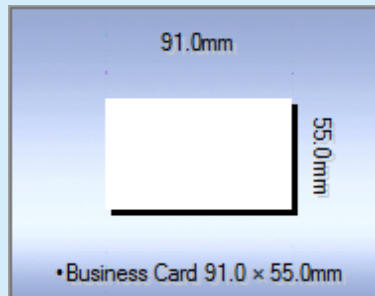

■ **Customize**

Any paper size of your choice can be set.

Unlike user-definable paper sizes, paper sizes can be set temporarily from the [Print Setup] dialog box, though the paper names cannot be changed.

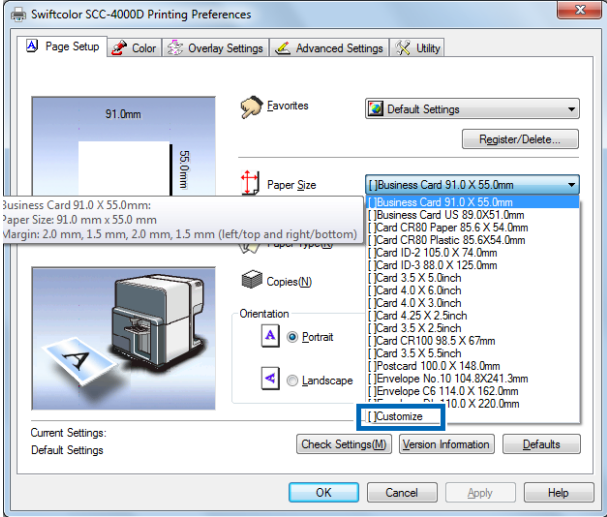

Paper Size	Shape of Media	Paper Size (W×L) mm	Margins (mm)			
			Top Margin	Bottom Margin	Left Margin	Right Margin
Customize		100.0 × 148.0	1.5	1.5	2.2	2.2

Note

- The setting of [Customize] that has been entered by opening the [Printing Preferences] dialog box from application software is erased at the same time as the software is closed.

3-2-5. Custom Paper Size Settings

If the desired paper size is not found in [Paper Size], set a new paper size in [Custom Paper Size Settings].

Up to 50 different paper sizes can be registered in [Custom Paper Size Settings]. In addition, preregistered standard label paper sizes may also be modified as desired and newly registered.

Note

- “Paper Size Name”, “Width”, “Length”, “Display Unit”, “Paper Shape” and “Margins” can be registered.
- Because the standard paper name cannot be changed, register the custom paper under a different name.

1

Select the basic paper size from [Paper Sizes List].

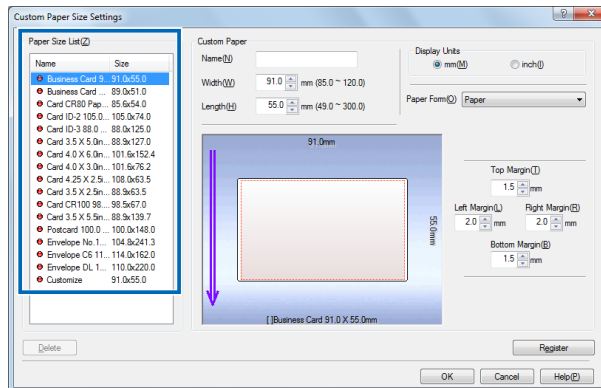

2

Enter or select the “Name,” “Width,” “Length,” “Margin,” “Display Unit” and “Paper Form” items in the [Custom Paper] field.

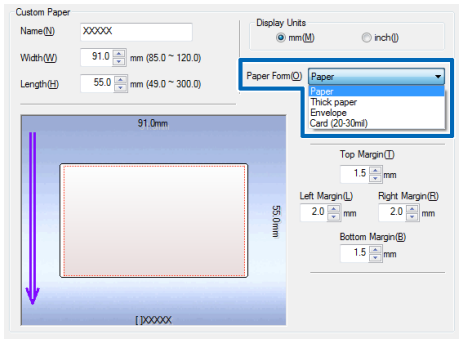
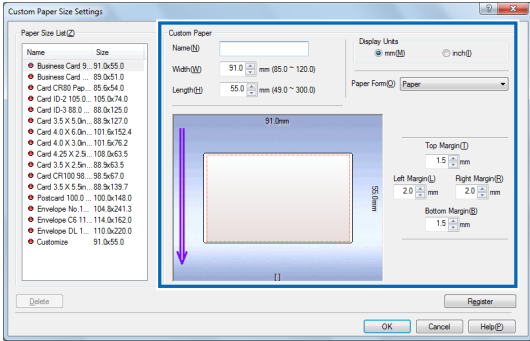

Name	Enter a new paper name. The name can be up to 15 single-byte and double-byte characters long.		
W x L	Enter a numeric value within the allowable range.		
Display Unit	Either mm or inch can be set.		
Shape of Media	Paper	Thickness: 0.21 mm - 0.27mm	Business Card/ Business Card US/ Card/ Postcard
	Card(20-30mil)	Thickness: 0.5 mm - 0.75mm	Plastic card
	Envelope	Maximum overall paper thickness: 0.28 mm - 0.45mm	No.10/C6/DL
	Thick paper	Thickness 0.76mm	Business Card/ Business Card US/ Card/ Postcard
Margins	Enter top and bottom and left and right margins.		

3. How to Use the Printer Driver

[Acceptable custom paper size range]

Shape of Media	Paper/Thick paper/Card(20-30mil)		Envelope	
	Minimum	Maximum	Minimum	Maximum
Paper Width mm (inch)	85.0	120.0	85.0	120.0
	(3.2)	(4.7)	(3.2)	(4.7)
Paper Length mm (inch)	49.0	300.0	73.0	270.0
	(1.9)	(11.8)	(2.9)	(10.6)
Top margin mm (inch)	1.5	Paper Length - 3mm - Bottom margin	1.5	Paper Length - 3mm - Bottom margin
	(0.06)		(0.06)	
Bottom margin mm (inch)	1.5	Paper Length - 3mm - Top margin	1.5	Paper Length - 3mm - Top margin
	(0.06)		(0.06)	
Left margin mm (inch)	2.0	Paper Width - 3mm - Right margin	2.0	Paper Width - 3mm - Right margin
	(0.06)		(0.1)	
Right margin mm (inch)	2.0	Paper Width - 3mm - Left margin	2.0	Paper Width - 3mm - Left margin
	(0.06)		(0.1)	

■ Paper setup confirmation diagram

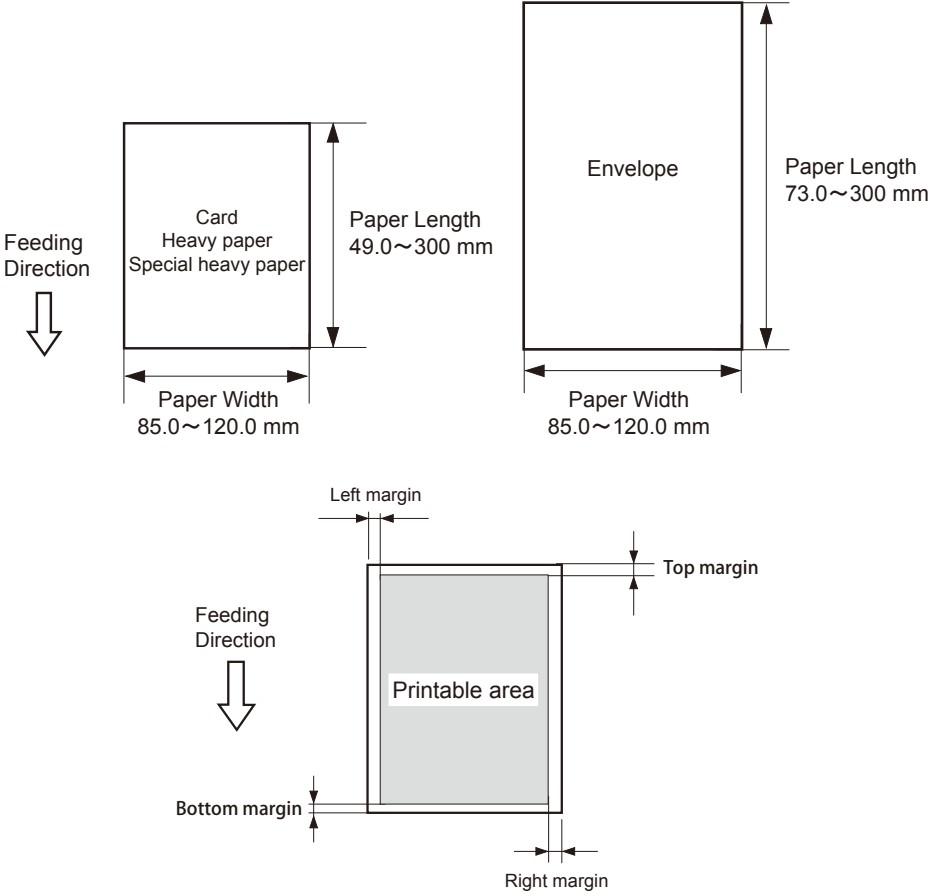

Note

- Using a wrong size of paper can stain the transport area for ink.

3. How to Use the Printer Driver

3

When entire entry is completed, click [Register].

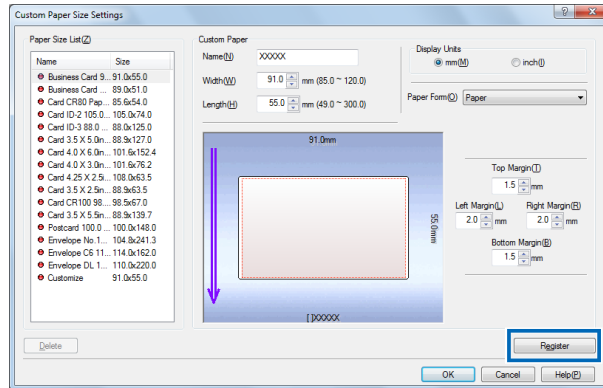

4

Click [Yes].

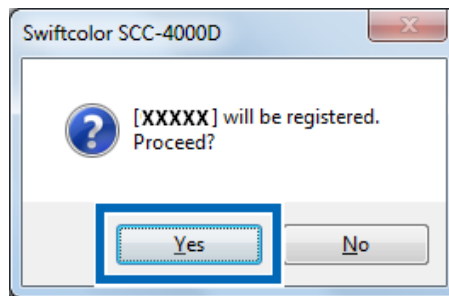

5

Check that the paper name as entered is displayed in the list in [Paper Size List] and click [OK].

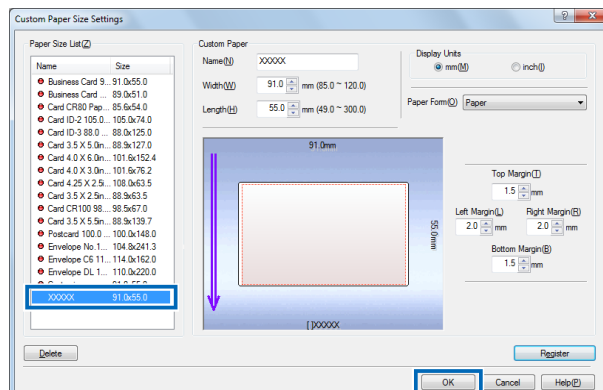

3-2-6.Paper Type

In [Paper Type], select the type of paper to print on.

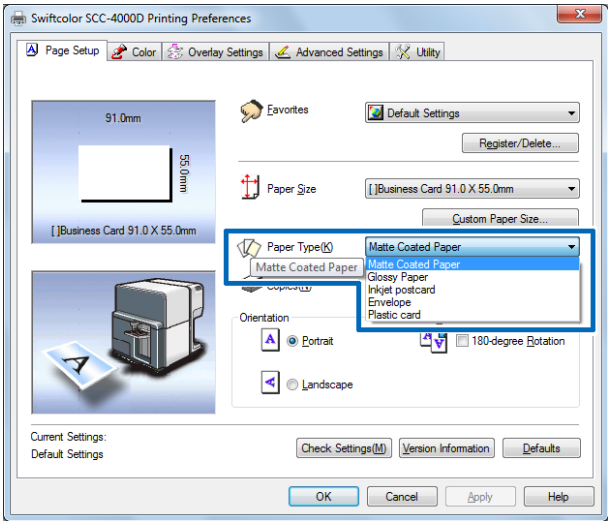

Matte Coated Paper	Non-glossy paper that fits into a broad range of applications, such as regular printing.
Glossy paper	Choose when you select Glossy paper to print.
Inkjet postcard	Choose when you select Inkjetpostcard to print.
Envelope	Choose when you select Envelope to print.
Plastic Card	Choose when you select Plastic card to print.

Note

- Remember that, if a paper type that is not supported by the printer is selected in [Paper Type], correct print results would be unpredictable.

3-2-7.Orientation

In [Orientation], select the direction in which to print documents.

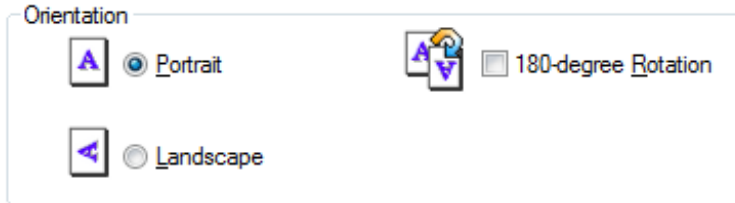

The results of printing of the following kind of document are assumed in the descriptions of the settings that follow.

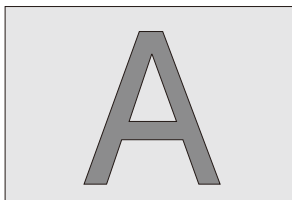

Portrait

Select this option to print the document rotated 90 degrees to the right in relation to the direction of paper feeding.

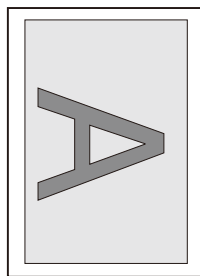

Direction of paper feed

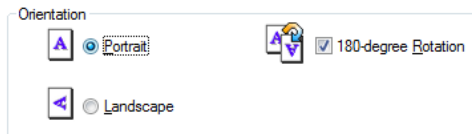
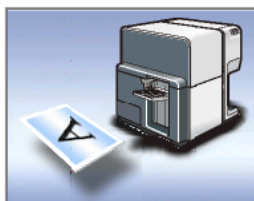

Landscape

Select this option to print the document horizontally in relation to the direction of paper feeding.

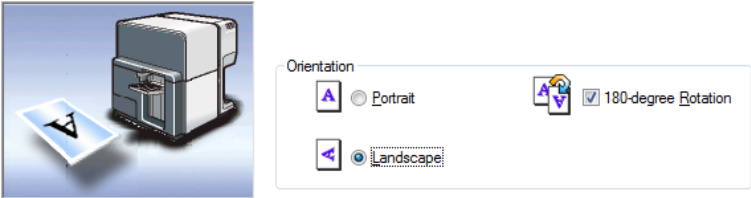
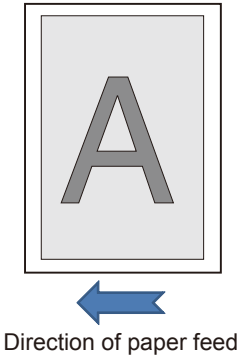

180-degree Rotation

Check this check box to print a document set for [Portrait] or [Landscape] rotated 180 degrees.

Portrait/rotated 180 degrees

Landscape/rotated 180 degrees

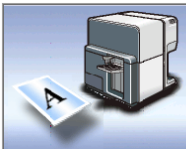
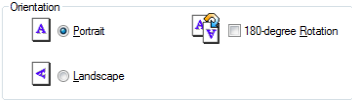
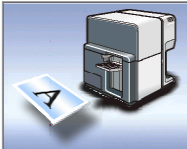
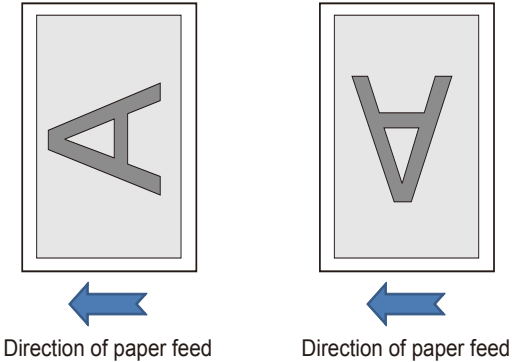

3. How to Use the Printer Driver

Note

- The current printing direction can be identified in a preview.

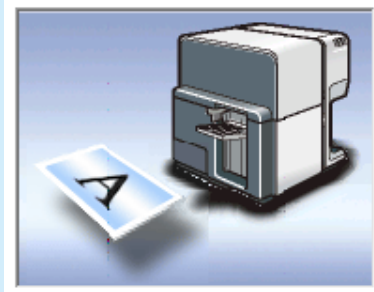

3-2-8. Check Settings

Click [Check Settings] to confirm the current paper settings.

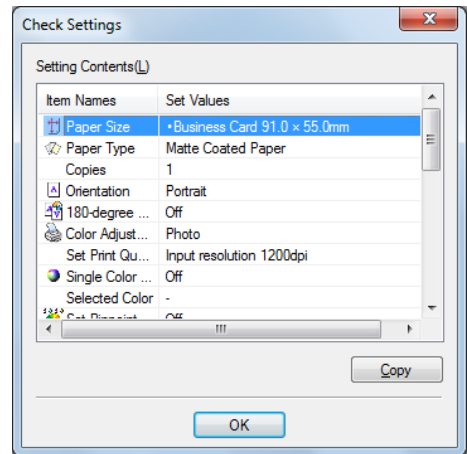
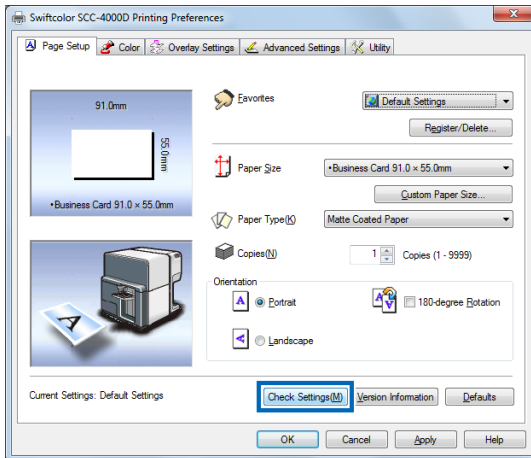

Note

- The [Copy] in [Check Settings] is used to copy the current settings to the clipboard in the OS.

3-2-9. Version Information

Information such as version and copyright on the printer driver can be confirmed.
Click [Version Information] to open the [Version Info] dialog box.

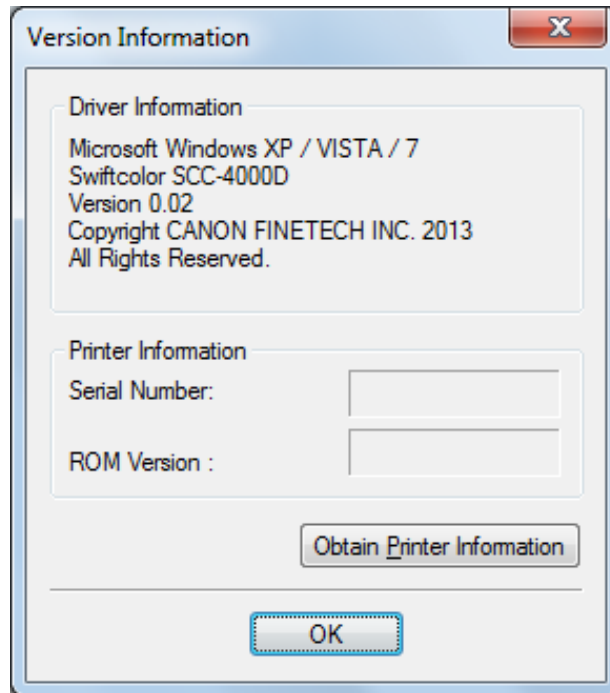

Click [Obtain Printer Information] to get information on the printer connected.

Note

- Serial number: Printer serial number
- ROM Version: Printer ROM version
- Printer information may not be collected depending on the status of printer connection.
 - Not connected to the printer.
 - Telecommunications lines or networks are busy.

3-3 Using the Color Dialog Box

The [Color] sheet is described below.

The [Color] sheet is used to set print picture quality and colors.

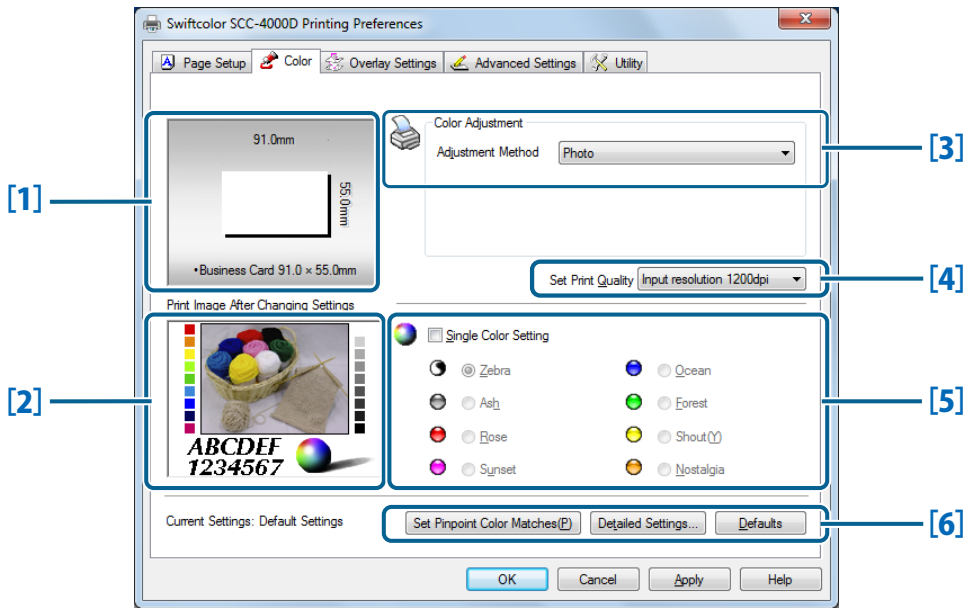

[1] Paper Size Preview

The currently set paper size is displayed in a preview.

[2] Print image of print data reflecting changes to the settings

A print image of the print data that has been subjected to color adjustment is displayed in a preview.

[3] Color Adjustment

Specify the optimal method of color processing using the driver's color correction function.

→ [3-3-1.Color Adjustment \(P.67\)](#)

[4] Set Print Quality

Select an input resolution between [Input resolution 1200dpi] and [Input resolution 600dpi].

→ [3-3-2.Set Print Quality \(P.69\)](#)

[5] **Single Color Setting**

Prints color image data in a specified single color. → 3-3-3.Single Color Setting (P.70)

[6] **Set Special Color**

Special Color Registration must have been completed in the [Utility] sheet to import. → 3-7-3. Pinpoint Color Matches (P.99)

Detailed Setting

Set [Color Balance], [Brightness], [Density], [Contrast], [Halftone Process], [Level Correction] and [Sharpness]. → 3-4 Using the Detailed Settings Dialog Box (P.72)

Defaults

Reset [Color] to its defaults.

3-3-1.Color Adjustment

[Color Adjustment] adjusts the tint to suit documents. When printing a landscape or portrait picture, select “Photo” in [Color Adjustment].

[Color Adjustment] is selectable from the following four items:

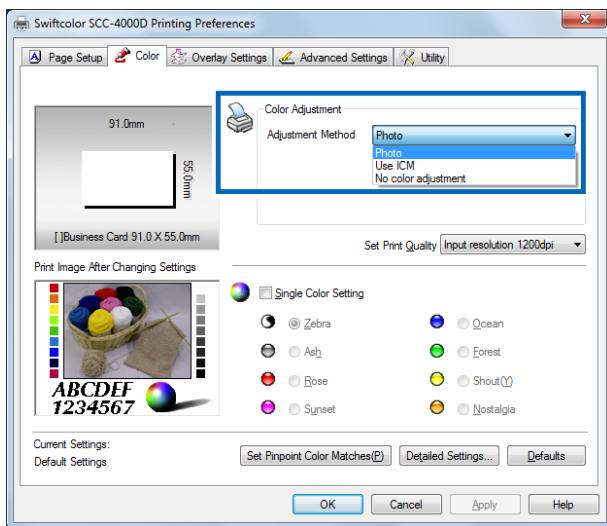

3. How to Use the Printer Driver

Photo

Select for printing photographic images.

Use ICM

Select this option to correct colors using the Windows color correction function of ICM (Image Color Management).

No color adjustment

No color adjustment.

Important

- When [Color Adjustment] is set to [Use ICM], [Set Pinpoint Color Matches] in the [Utility] sheet cannot be used. To use [Set Pinpoint Color Matches], select an option other than [Use ICM].

→ [3-7-3. Pinpoint Color Matches \(P.99\)](#)

Note

- If print data includes both photographs and graphics, select “Photo.”
- If [Use ICM] has been selected in [Color Adjustment], [Brightness] in [Detailed Settings] would appear grayed and would not be functional.

3-3-2.Set Print Quality

Set the print quality.

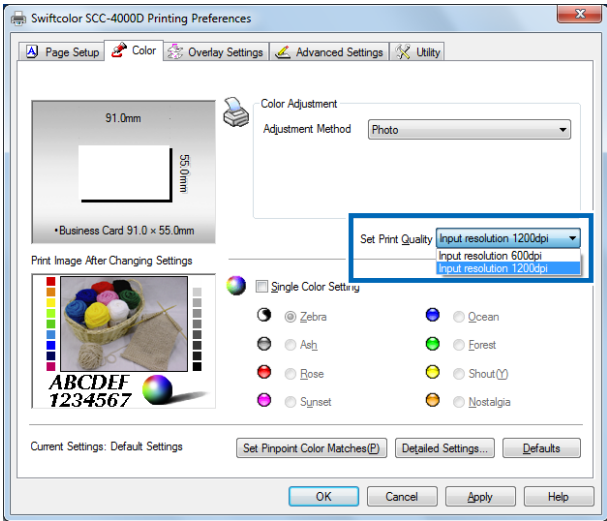

Input resolution 1200dpi	Prints at 1200X1200dpi	Prints data after processing it for a resolution of 1200 × 1200 dpi.
Input resolution 600dpi	Prints at 600X600dpi	Prints data after processing it for a resolution of 600 × 600 dpi. (Speed priority)

3-3-3. Single Color Setting

[Single Color Setting] prints multi-colored documents in a single color.

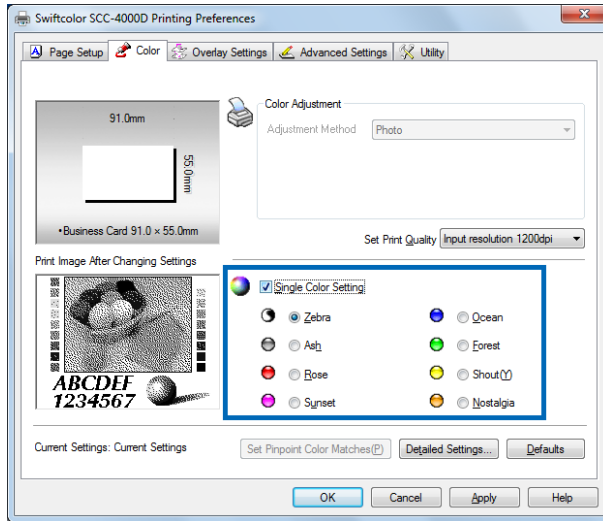

To print in a single color, click the [Single Color Setting] check box and check-select the color to use. To cancel the single color option, uncheck [Single Color Setting].

Zebra	Prints in Black and White only.	Prints using Black ink only.
Ash	Prints in a Gray single color.	Prints using all the four-color inks.
Rose	Prints sin a Red single color.	
Sunset	Prints in a Purple single color.	
Ocean	Prints in a Blue single color.	
Forest	Prints in a Green single color.	
Shout	Prints in a Yellow single color.	
Nostalgia	Prints in a Sepia single color.	

Note

- If [Zebra] is selected, [Color Adjustment] in “Color” sheet and [Color Balance], [Density], [Contrast] and [Level Correction] in [Detailed Settings] would appear grayed and would not be functional.
- All the selections for single color setting become dimmed and disabled after you remove the checkmark of the Single Color Setting checkbox.

Important

- If [Use ICM] is selected in "Color Adjustment" or [Zebra] is selected in "Single Color Setting", a warning is displayed and [Register Special Color] cannot be used. To use [Register Special Color], select an option other than [Use ICM] and [Zebra] when setting colors using the printer driver.

→ [3-7-3. Pinpoint Color Matches \(P.99\)](#)

3-4 Using the Detailed Settings Dialog Box

Use the [Detailed Settings] dialog box to enter more detailed settings in the [Color] sheet.

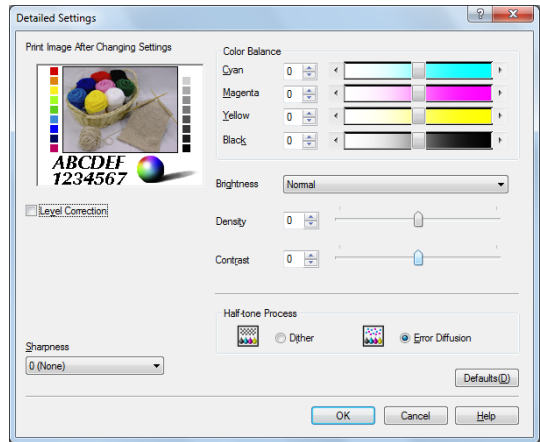
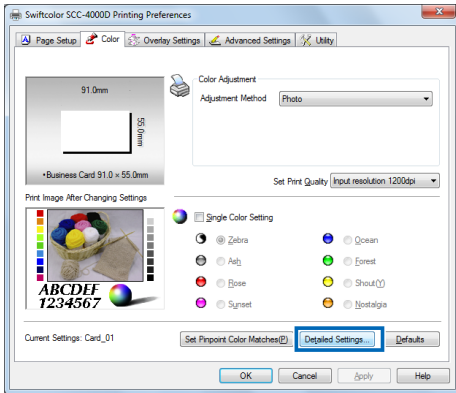

3-4-1. Color Balance

[Color Balance] adjusts the density of Cyan, Magenta, Yellow and Black.

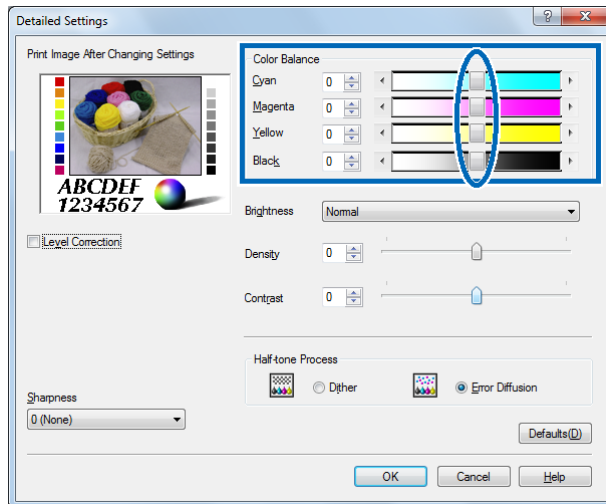

Either drag the slider or type a value directly to adjust the density.

Set the density between -50 and +50.

The slider represents the standard density setting (0) at the middle. Drag the slider to the left for

a lighter image and to the right for a darker image. When the adjustment process is complete, click [OK].

Note

- A value can be also entered by clicking the entry box on the left side of the slide bar. Further, click the buttons at both ends of the slide bar to increment or decrement the current value by one.
- Click [Defaults] to initialize the printer to the factory defaults.
- The setting result is displayed in the [Output image after setting change] preview window.

3-4-2. Brightness

[Brightness] adjusts brightness if the print results appear too dark or bright as a whole. This adjustment adjusts the brightness of intermediate colors without varying the shading of the darkest and brightest portions.

[Brightness] is selectable from the following three choices:

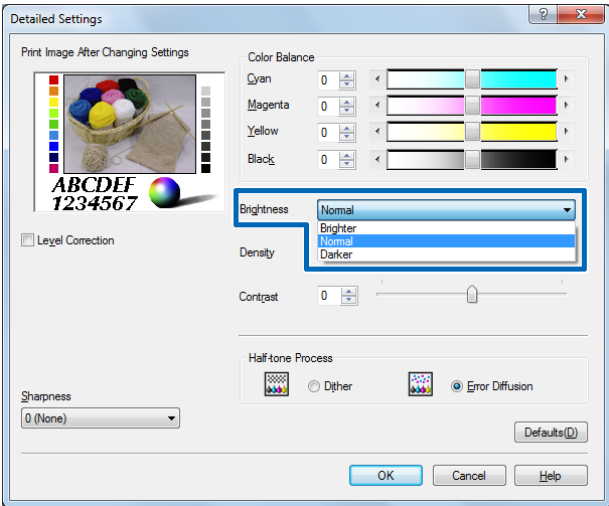

Brighter

- **Nears a monitor having a gamma function of 1.4.**
- Prints the data bright.
- Select this option when the print results are felt too dark.

3. How to Use the Printer Driver

Normal

Nears a monitor having a gamma function of 1.8.

Prints with regular brightness.

Print with this setting first. Then, select [Bright] or [Dark] to suit the print results as needed.

Darker

Nears a monitor having a gamma function of 2.2.

Prints the data dark.

Select this option when the print results are felt too bright.

After the setup, click [OK].

Note

- The Brightness control is dimmed and disabled after selecting [Use ICM] or [No color adjustment] for Color Adjustment.
- The setting result is displayed in the [Output image after setting change] preview window.

3-4-3. Density

Drag the [Density] slider to determine over all density.

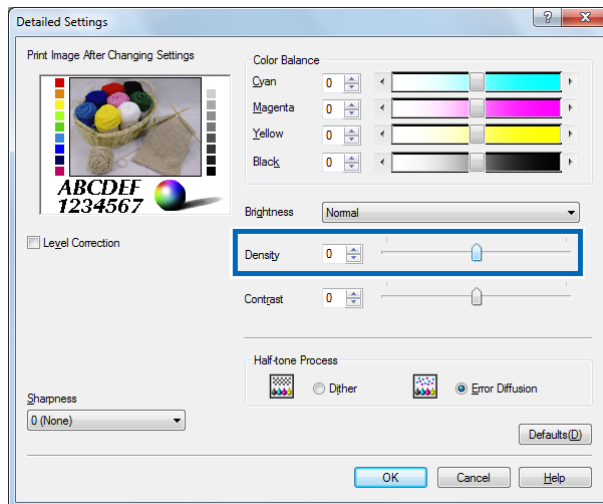

Set the density between -50 and +50.

The slider represents the standard density setting (0) at the middle. Drag the slider to the left for a lighter image and to the right for a darker image. When the adjustment process is complete, click [OK].

Note

- A value can be also entered by clicking the entry box on the left side of the slide bar.
- Click [Defaults] to initialize the printer to the factory defaults.
- The setting result is displayed in the [Output image after setting change] preview window.

3-4-4. Contrast

Drag the [Contrast] slider to determine overall contrast.

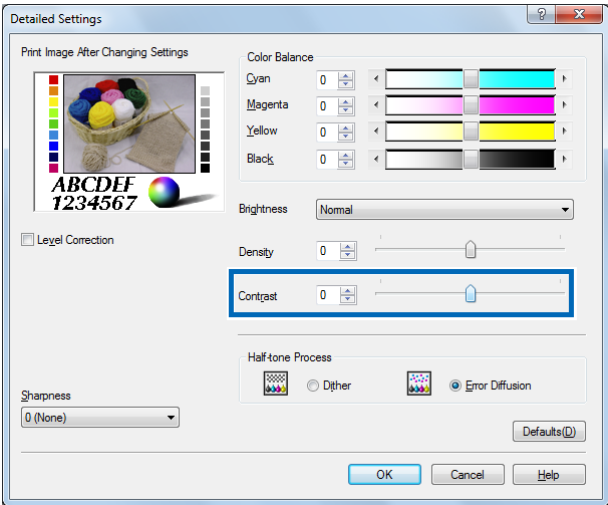

Set the contrast between -50 and +50.

The slider represents the standard contrast setting (0) at the middle. Drag it to the left to get a smoother tone representation with a broader width between the dark and bright edges. Dragging the slider too far will make images look blurred.

The farther the slider is dragged to the right, the darker dark portion of image will appear. Or the whiter, white portion of image will appear. But the tone of colors will be lost. After setting up, click [OK].

Note

- Contrast refers to the width (tolerable) from the Black portion of an image to the White portion.
- A value can be entered by clicking the entry box on the left side of the slide bar.
- Click [Reset to Defaults] to initialize the printer to the factory defaults.
- The setting result is displayed in the [Output image after setting change] preview window.

3-4-5. Halftone Process

Click either the dither or error diffusion check box.

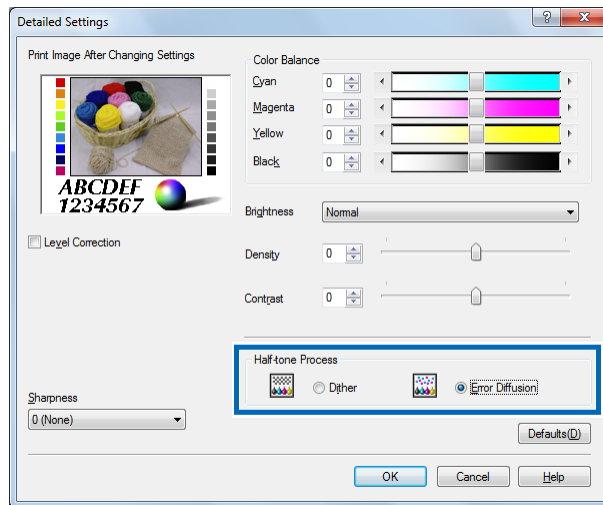

Dither

Arranges dots regularly to represent halftones. This is suitable for printing graphics or similar materials in which color boundaries need to appear crisp.

Error diffusion

Arranges dots randomly to represent halftones. This is suitable for printing pictures that dictate delicate gradation.

After the setup, click [OK].

3-4-6. Level Correction

[Level Correction] enhances the contrast of images when they appear to have low contrast (lacking clear distinction between darkness and brightness) in the print results. Level correction prints the bright portion of a document brighter and the dark portion darker.

To carry out level correct, click-select the [Level Correction] check box. If level correction is not required, uncheck the [Level Correction] check box.

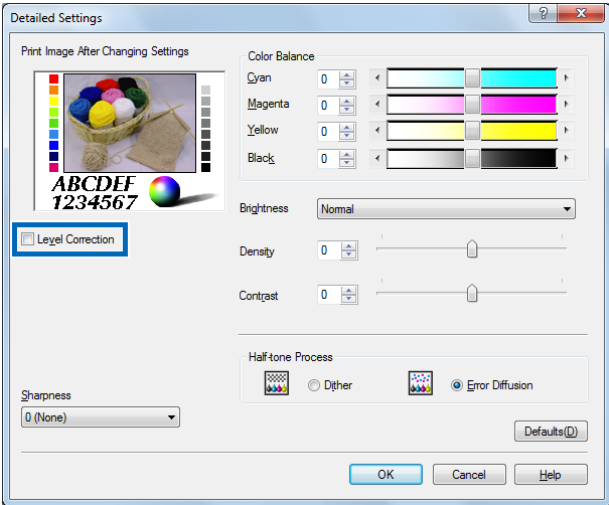

After the setup, click [OK].

Note

- The setting result is displayed in the [Output image after setting change] preview window.

3-4-7. Sharpness

[Sharpness] sharpens images when they appear blurred as a whole in the print results. Sharpness is selectable in a pulldown menu from among 0 (No), 1 (Small), 2 (Medium) and 3 (Large).

The setting is displayed on the left side of the slider.

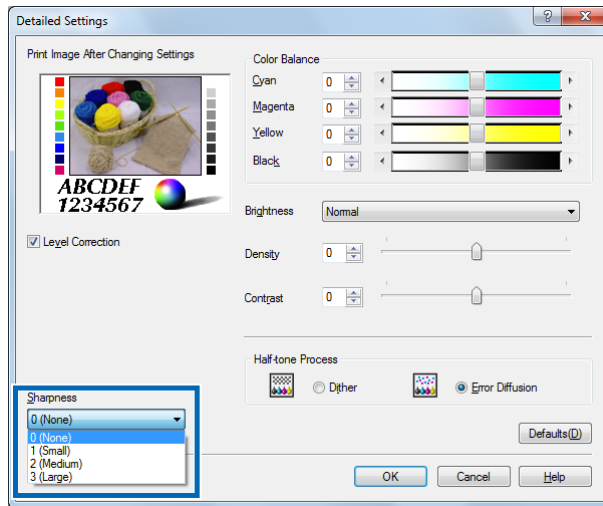

0 (None)	Sharpness correction is not applied..
1 (Small)	Sharpness processing is done.
2 (Medium)	Sharpness processing is done.
3 (Large)	Sharpness processing is done.

After the setup, click [OK].

Note

- The setting result is displayed in the [Output image after setting change] preview window.

3-5 Using the Overlay Settings Dialog Box

The [Overlay Settings] sheet is described below.

In overlay printing, a background image that has been created as a form file beforehand can be overlaid with a foreground image or text on printing.

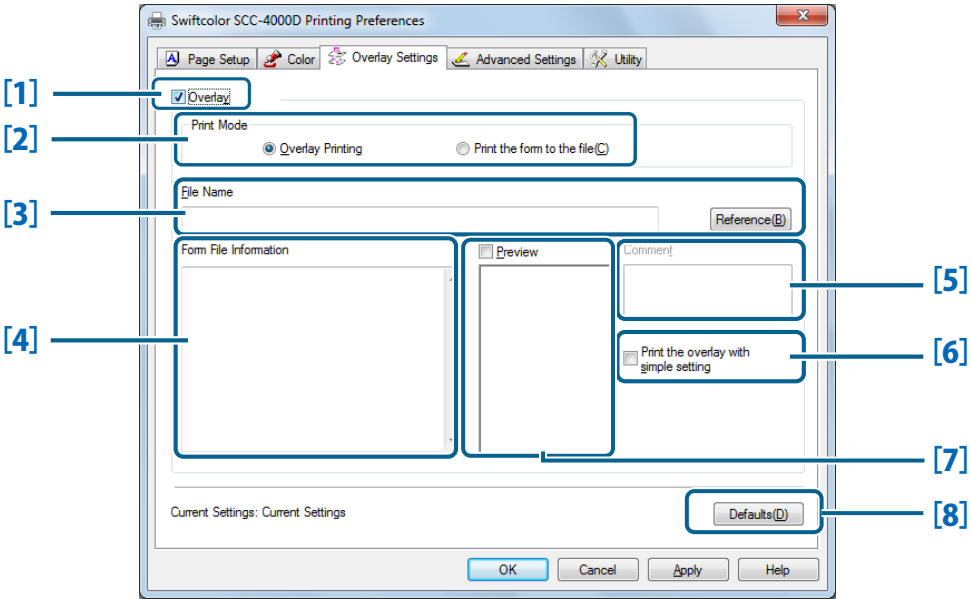

[1]	Overlay	If this option is checked, overlay printing is enabled.
[2]	Print Mode	Set up for overlay printing or form file creation.
[3]	File Name	Set the file path of a form file used for overlay printing or where to save the form file.
[4]	Form File Information	Displays print setup information about the form file that has been selected in [File Name].
[5]	Comment	Displays the title of the form file that has been selected in [File Name].
[6]	Print the overlay with simple setting	Set whether to perform masking or overlaying on the form file and print data.
[7]	Preview	If this option is checked, the file that has been selected in [File Name] is displayed in a preview.
[8]	Defaults	Reset the overlay setting to the default.

3. How to Use the Printer Driver

Note

- This function will not work properly if the printer driver of the server is configured for shared use and a client uses that shared printer server to perform printing.

3-5-1. Create Form

To create a form file, check that the printer is in the online mode.
Create a form file (background image) to be used for overlay printing.

1 Select [Print] from the application which image data has been created, select "Swiftcolor SCC-4000D" as a printer name and select [Properties], [Advanced Settings] and so on.

2 Click the [Overlay Settings] tab in the [Swiftcolor SCC-4000D Properties] dialog box in the printer driver to open the [Overlay Settings] sheet.

Check [Overlay].

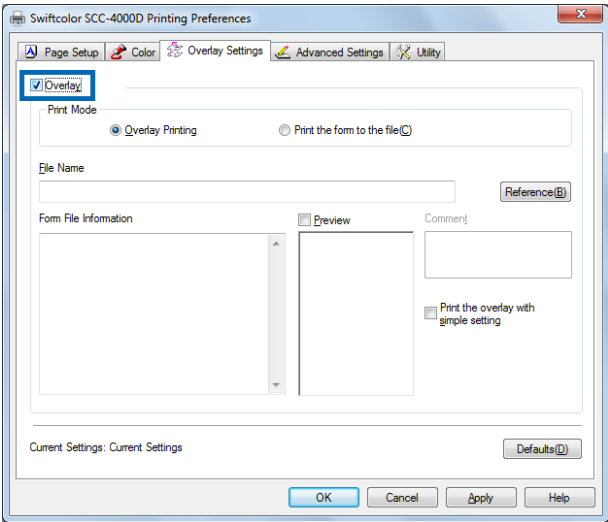

3

Next, check [Print the form to the file] in [Print Mode].

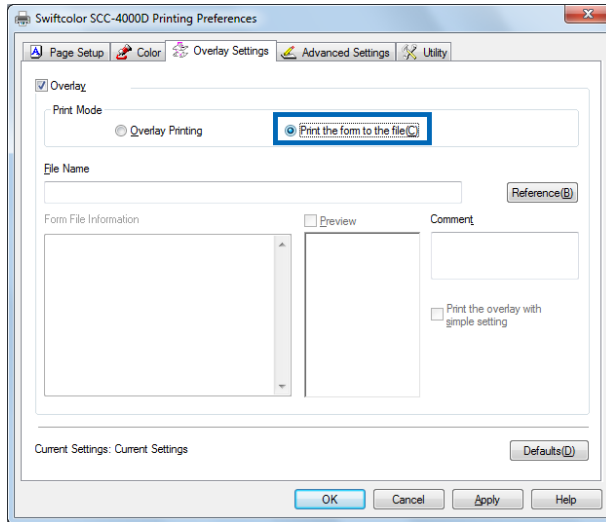

4

Specify [File Name] and location to save the file.

Click [Reference] and set a file name and location to save the form file.

File Name: Set any name.

Location to save file: Decide a location to save and create a folder with a name.

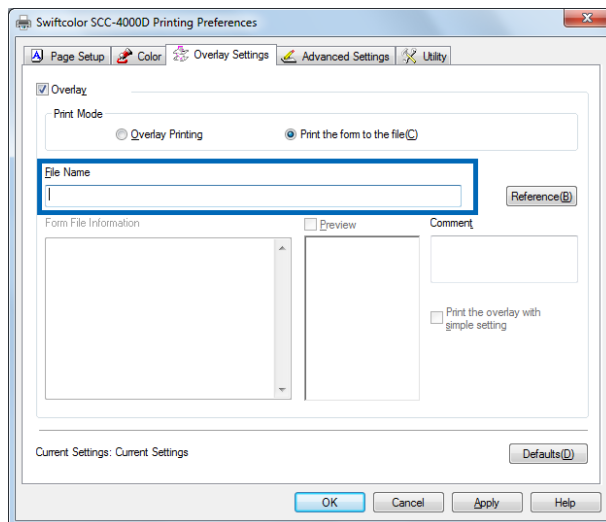

5

Enter [Comment].

The comment can be up to 31 single-byte and double-byte characters long, but its entry can be safely omitted.

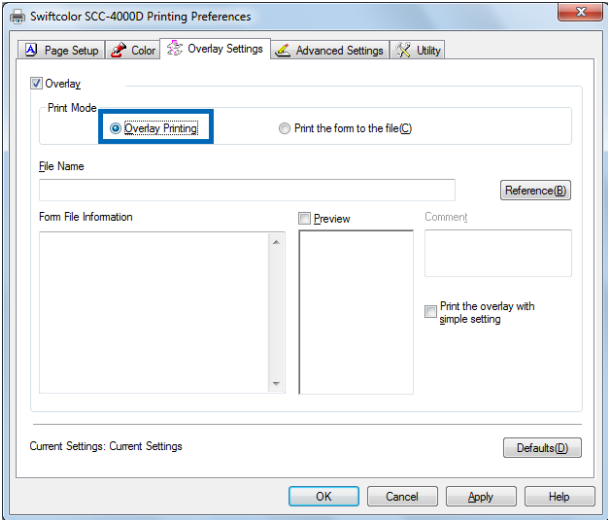

6

When the setup is complete, click [OK].

7

When the print execution window appears again, click [Print].

Prints data to be used as a form file.

8

The data is saved in the folder created in Step 4 as a form file.

Note

- Even if multi-page print data is created as a form file, it is also saved as a single file.

3-5-2. Overlay Printing

Uses the form file created for overlay printing.

1

Check [Overlay Printing] in [Print Mode].

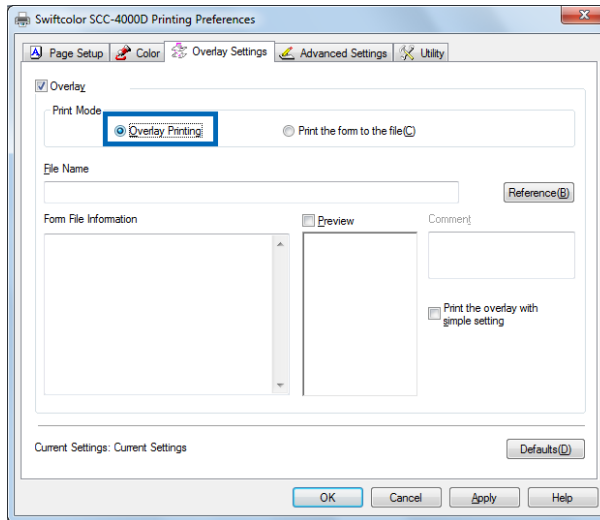

2

Click [Reference] to select the form file that has been created.

Check the selected form file in [Form File Information] and [Preview].

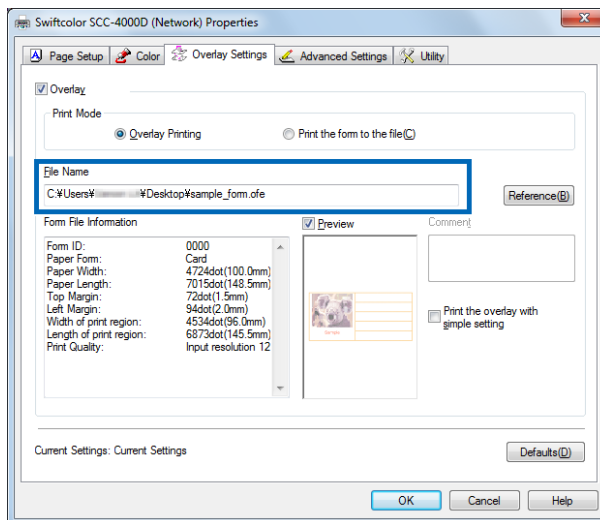

3

Click [OK].

Note

- If a print job is executed with [Print the overlay with simple setting] checked, the form file and print data are overlaid with each other (foundation preserved).

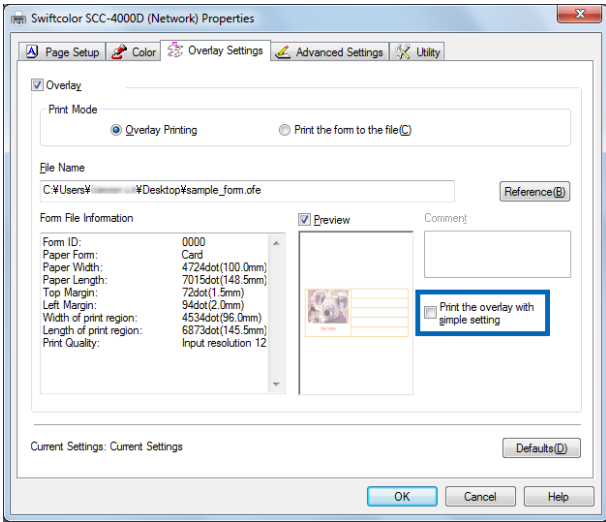

	Print the overlay with simple setting	Handling	Content
[1]	Check Off	Prints data overlaid with a form file by masking (void foundation).	Overlay printing with a void foundation helps preserve the original image colors.
[2]	Check On - If checked, a warning will be displayed.	Prints data overlaid with a form file with the foundation preserved.	Because of overlay printing with the foundation preserved, the image is discolored as its colors overlap the foundation. Processing is made faster than [Standard].

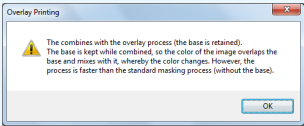

4 Executes a print job.

Print data is printed overlaid with the form file.

Note

- Overlay printing would be disabled if the print setup information differs between the print data and the form file.
- When a document is printed in single color zebra, it can be overlaid with form data even if it varies in the number of colors.
- Overlay printing may not work if the printer driver with which the form has been created has an invalid version or the like. In this case, create a form file with the printer driver to be used for overlay printing.
- [Form File Information] or [Preview] may not be displayed depending on the form file.

3-6 Using the Advanced Dialog Box

The [Advanced Settings] sheet is used to set a print Order, Paper feed interval and so on.

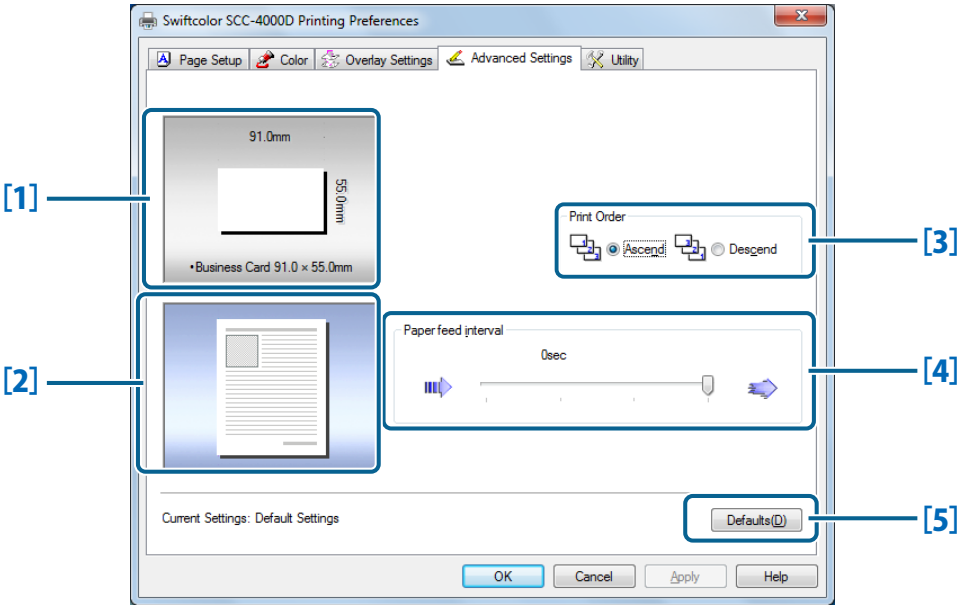

- [1] **Paper Size Preview**
The currently set paper size is displayed in a preview.
- [2] **Form File Information Display**
The result of Layout setting and Frame Printing setting is displayed in the preview window.
- [3] **Print Order**
Set the order of printing. → [3-6-1. Print Order \(P.89\)](#)
- [4] **Paper feed interval**
Set the paper feed interval. → [3-6-2. Paper Feed Interval \(P.89\)](#)
- [5] **Defaults**
Resets [Advanced Settings] to the defaults.

3. How to Use the Printer Driver

Important

- The setting of [Print Order] is disabled unless [Enable advanced printing features] is checked in the [Advanced Settings] sheet in the [Swiftcolor SCC-4000D Properties] dialog box.

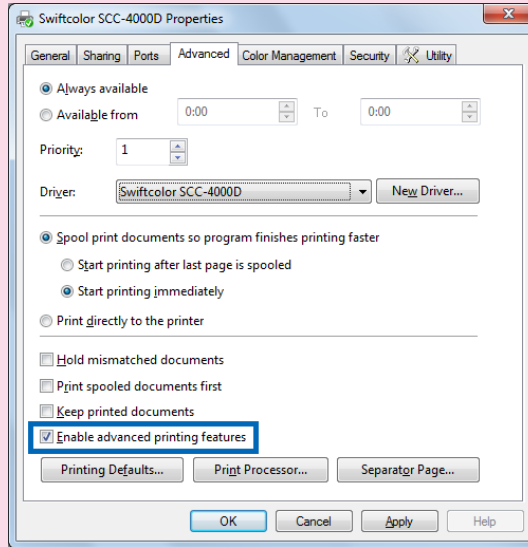

3-6-1. Print Order

Decide on whether to start printing from the first or last page.
To print from the first page afterwards, select [Ascend]; to print from the last page upward, select [Descend].

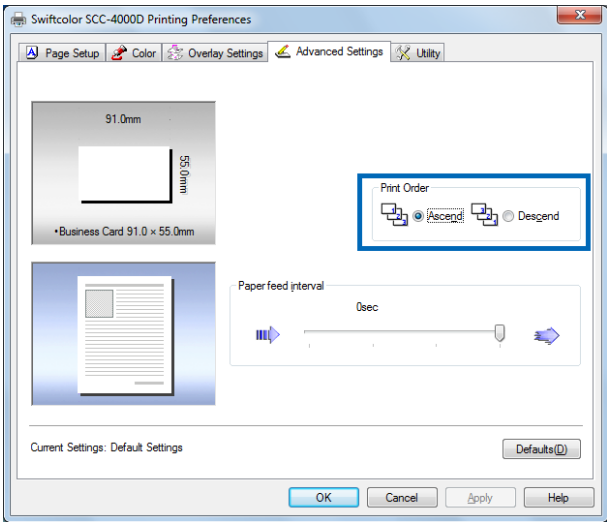

3-6-2. Paper Feed Interval

Setting the paper feed interval prevents a printed image to be copied to the back of the next paper.
The default has been set to the "0 sec".

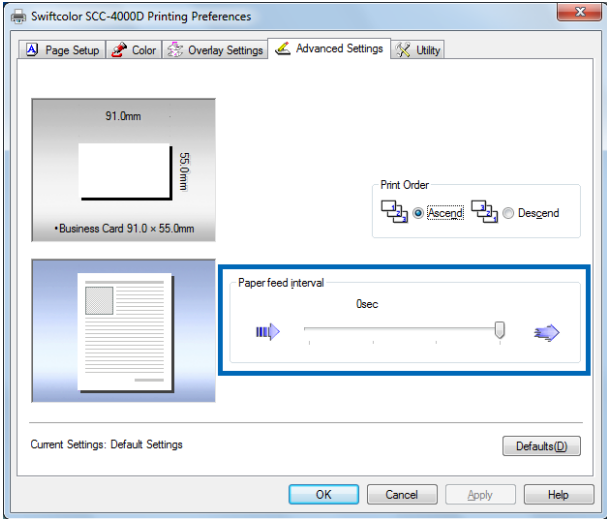

3. How to Use the Printer Driver

Note

- Normally, the slider is at the rightmost position.
Three scale marks representing 0 sec, 1 sec, 2 sec, and 3 sec are arranged from right.

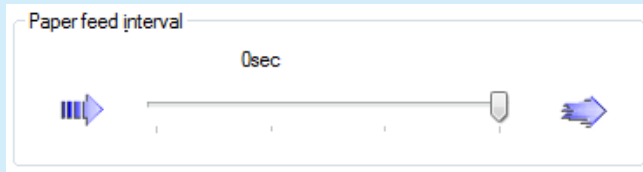

*When performing high-density printing on glossy paper, increase the paper feed interval.

3-7 Using the Utility Dialog box

The [Utility] sheet is used to configure settings for the printer maintenance, power saving and so on. Open the [Utility] sheet also when starting the Status Monitor.

- 1** Select [Devices and Printers] from the Start menu in Windows.
- 2** Select and right-click on [Swiftcolor SCC-4000D].
- 3** Select [Printer Properties] and click the [Utility] tab.

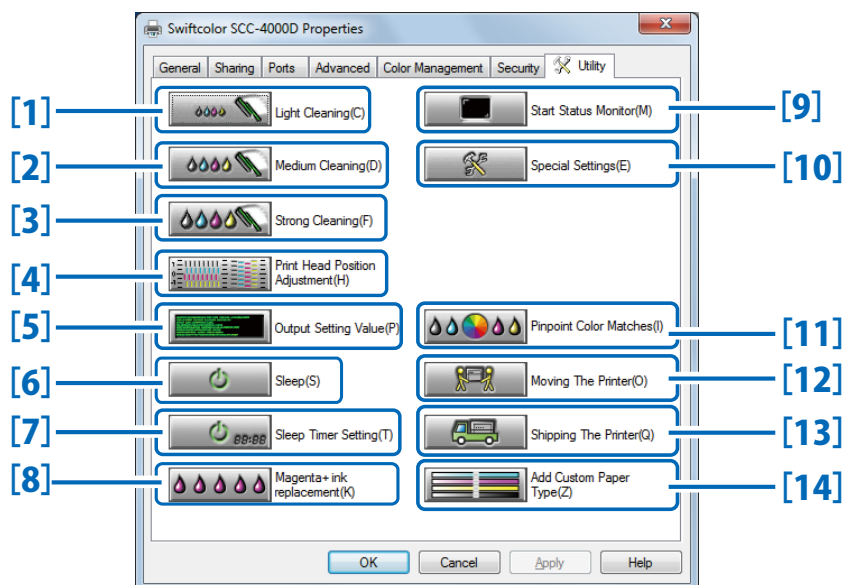

[1] Light Cleaning

Cleans the Printheads.

→ [5-1 Cleaning the Printhead \(P.135\)](#)

[2] Medium Cleaning

Performs cleaning somewhat stronger than Light Cleaning.

→ [5-1 Cleaning the Printhead \(P.135\)](#)

[3] Strong Cleaning

Performs cleaning somewhat stronger than Medium Cleaning.

→ [5-1 Cleaning the Printhead \(P.135\)](#)

3. How to Use the Printer Driver

[4] **Print Head Position Adjustment**

Adjusts the Printhead positions. → [5-2 Adjusting the Printhead Position \(P.137\)](#)

[5] **Output Setting Value**

Prints the current settings of the printer. → [5-4 Check the Output Setting Value \(P.162\)](#)

[6] **Sleep**

Switches the printer to the sleep mode. → [3-7-1. Sleep \(P.94\)](#)

[7] **Sleep Timer Setting**

Sets the interval of time to elapse to switch to the sleep mode and the power-off state. → [3-7-2. Sleep Timer Setting \(P.96\)](#)

[8] **Magenta+ ink replacement**

It is used when changing ink to New Magenta Ink [SCC-D400M+].
(This function is not used if [SCC-D400M+] ink has already been used.)

[9] **Start Status Monitor**

Displays the Status Monitor window. → [4-1-1. Starting the Status Monitor \(P.108\)](#)

[10] **Special Settings**

Configure custom printer settings. → [3-7-4. Special Settings \(P.111\)](#)

[11] **Pinpoint Color Matches**

Prints an image with colors close to the desired colors. → [3-7-3. Pinpoint Color Matches \(P.99\)](#)

[12] **Moving The Printer**

Prepares for relocating the printer on the same floor or to another floor in the same building. → [7-1 Moving the Printer \(P.188\)](#)

[13] **Shipping The Printer**

Prepares for long-haul transport, as on truck or aboard aircraft. → [7-2 Shipping the Printer \(P.192\)](#)

[14] **Add Custom Paper Type**

Allows the user to adjust ink jetting amounts and register them along with the paper type of new paper. → [3-7-5. Add Custom Paper Type \(P.114\)](#)

Important

- The printer must be turned on and connected to the computer to set items in the [Utility] sheet.
- To use [Print Head Position Adjustment], [Sleep Timer Setting], [Special Settings], [Register Special Color], [Moving The Printer], or [Shipping The Printer] displayed on the utility sheet, log in with the Administrator privilege.

If you log in using an authority other than Administrator, you cannot perform the operation. However, you can perform the operation by getting the Administrator privilege temporarily.

<To perform the above-mentioned operation using an authority other than the Administrator privilege.>

Windows 7: Open [Printer Properties], and then click [Change Properties] on the [General] sheet. If the “User Account Control” screen appears, enter the Administrator password, and then click [Yes].

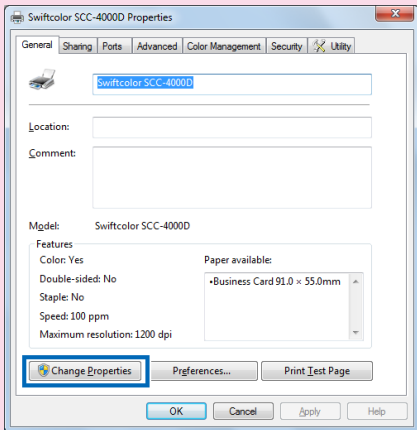

Windows Vista: Right-click on the printer driver icon, and then select [Run as administrator]→[Properties]. If the “User Account Control” screen appears, enter the Administrator password, and then click [Yes].

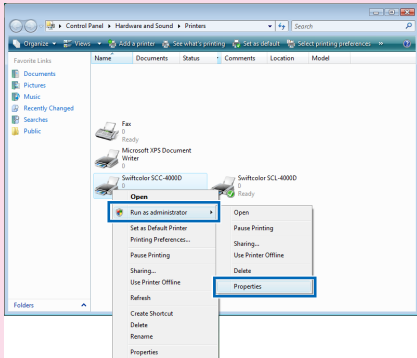

3-7-1. Sleep

Click [Sleep] to switch the printer to the sleep mode.

Note

- The printer cannot be switched to sleep mode while it is printing.
- The printer enters the sleep mode automatically when it has been left idle for a certain period of time under normal conditions of operation.
- The printer emerges from the sleep mode and enters the normal state (ready to print) automatically in the following situations:
 - The [POWER] key is pressed.
 - A print job has been initiated from the computer.
 - Cleaning or any other operation has been initiated from the computer.

1

Check that the printer is in the online mode.

Check that the status lamp is lit.

2

Click [Sleep].

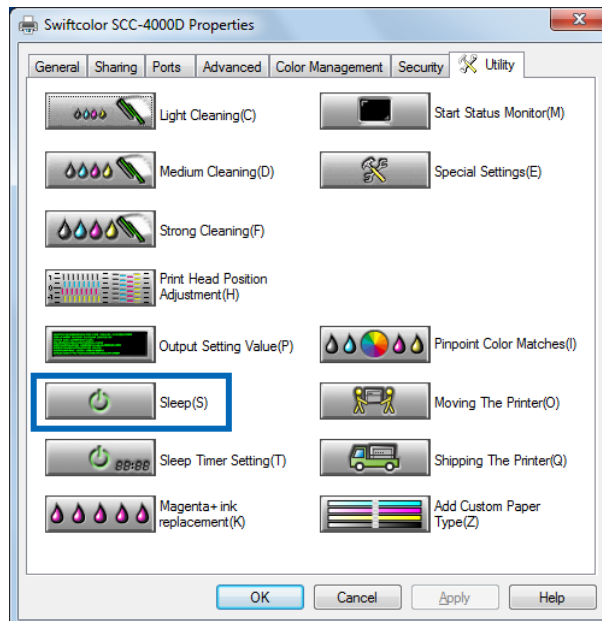

3

The confirmation dialog box appears, then click [Yes].

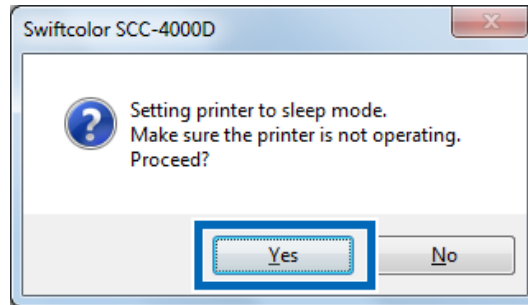

The printer enters the sleep mode with the power lamp blinking.

Note

- The printer would be inoperable if it is turned off. If so, press the [POWER] key to turn on the printer.

3-7-2. Sleep Timer Setting

[Sleep Timer Setting] allows you to set the time for the printer to enter the sleep mode automatically when the printer has been left idle for a certain period of time or when no print data has been received from the printer, and the time for the printer to be turned off subsequently.

Note

- The time interval setting of the sleep timer cannot be changed while printing is in progress or an error persists.
- [Sleep Timer Setting] defaults to 4 minutes.
- Off Timer Setup defaults to 240 minutes. The setting can be turned “ON” or “OFF.”
- Two kinds of setup are available: “Sleep Timer Setup” and “Off Timer Setup.”

Important

- If a warning is issued when you press the [Sleep Timer Setting], refer to the following:

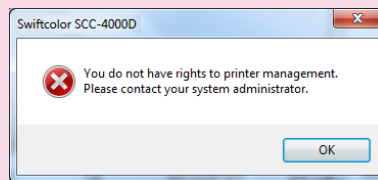

→ To perform the above-mentioned operation using an authority other than the Administrator privilege (P.93)

1

Check that the printer is in the online mode (POWER key lit in Green).

If the printer is not in the online mode, press the POWER key to place it into the online mode.

2

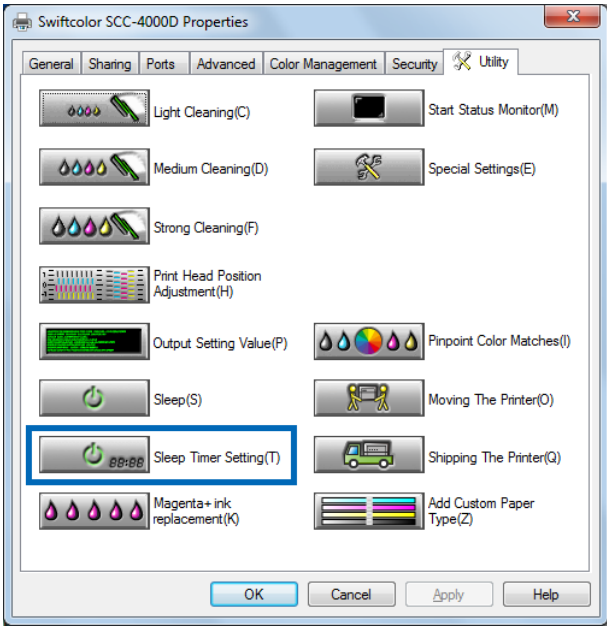

Click [Sleep Timer Setting].



The [Sleep Timer Setting] dialog box appears.

3

Enter time then click [Send].

Enter times for the sleep timer and the off timer from the keyboard or using the ,  buttons to the right of the entry box.

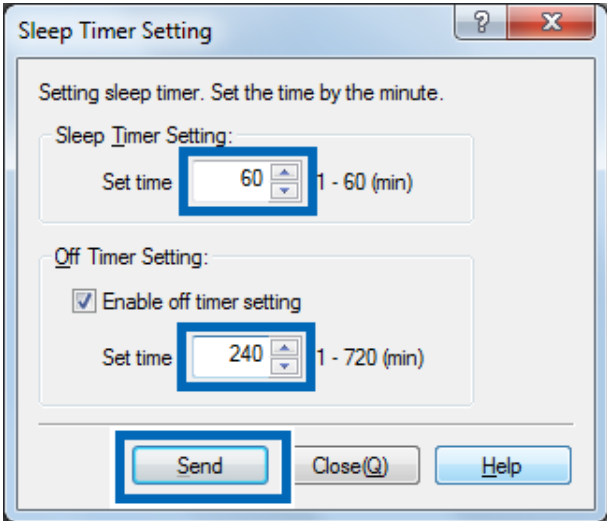

3. How to Use the Printer Driver

Name	Setting range (min.)	Addressable resolution (min.)	Function
Sleep timer setting	1 - 60	1	Setting to enter the sleep mode.
Off timer setting	1 - 720	1	Setting to enter the power-off state (Set the time longer than that for the sleep timer).

Note

- Off timer setting can be toggled between “Checked (enabled)” and “Unchecked (disabled)” as needed.

4

The confirmation dialog box appears, then click [Yes].

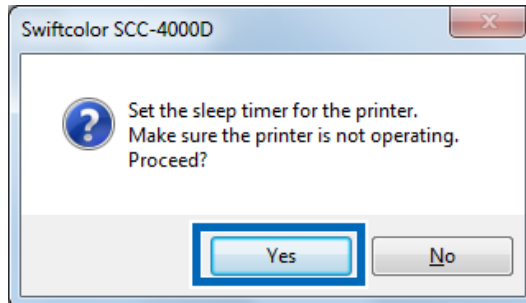

The time set for the sleep timer changes.

3-7-3. Pinpoint Color Matches

[Pinpoint Color Matches] allows you to create and register colors for special color matching, as for logo marks.

This setup method matches the printer colors with the colors in need.

Note

- [Pinpoint Color Matches] is a tool to create a color as similar as possible to the target color when the color of the printed image is different from the target color.

Determine the RGB value (one of 256 tones) of your desired color using Paint. Next, determine the color of the image to be printed using [Pinpoint Color Matches].

- Be sure to determine one target color. [Pinpoint Color Matches] cannot be used for images created through gradation.
- If an image created using the same RGB value as that of the target color exists in the same data, the registered color is also reflected in this image.

Important

- If a warning is issued when you press the [Pinpoint Color Matches], refer to the following:

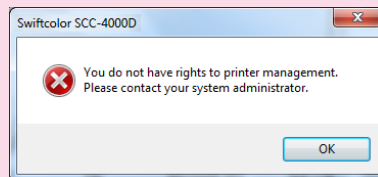

→ To perform the above-mentioned operation using an authority other than the Administrator privilege (P.93)

1

Click [Pinpoint Color Matches].

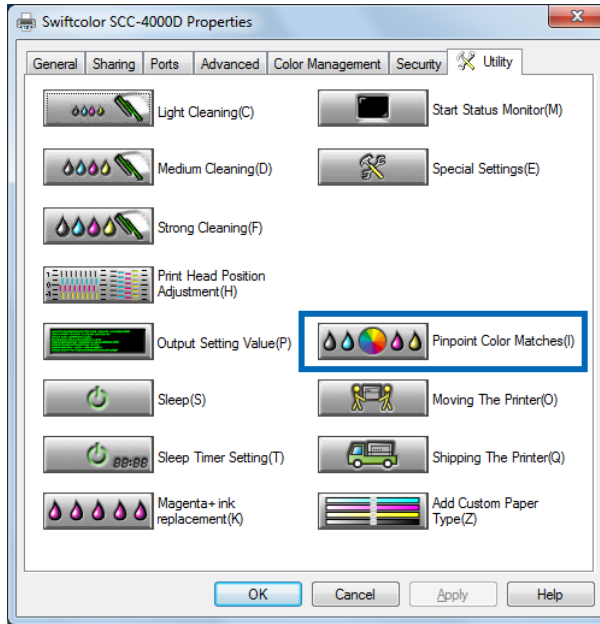

Important

- If [Use ICM] is selected in "Color Adjustment" or [Zebra] is selected in "Single Color Setting", a warning is displayed and [Pinpoint Color Matches] cannot be used.
 - [3-3-1.Color Adjustment \(P.67\)](#)
 - [3-3-3.Single Color Setting \(P.70\)](#)

2

[Pinpoint Color Matches] window appears.

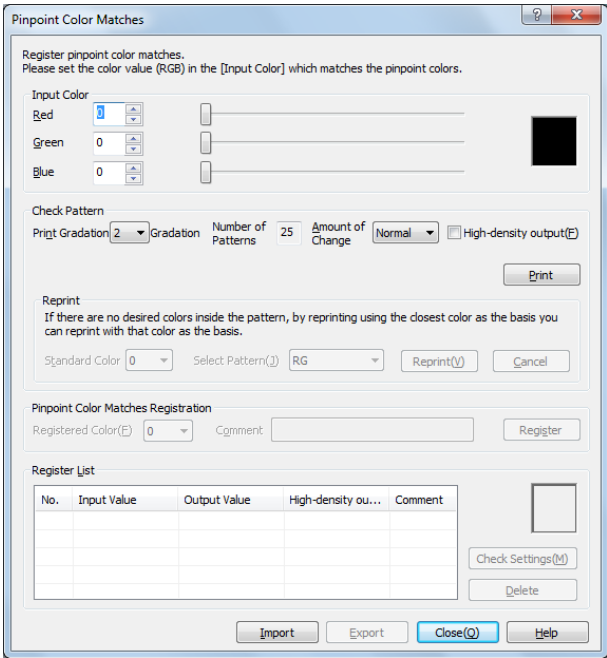

3

Read the values of R/G/B from the source image.

3. How to Use the Printer Driver

Note

- To read the R/G/B values from a source image that is subject to color matching, such as a logo mark, use an image processing program, such as “Paint,” which comes standard with Windows.

■ R/G/B value reading procedure (when using “Paint”)

1. Start “Paint,” which comes standard with your computer (Windows).

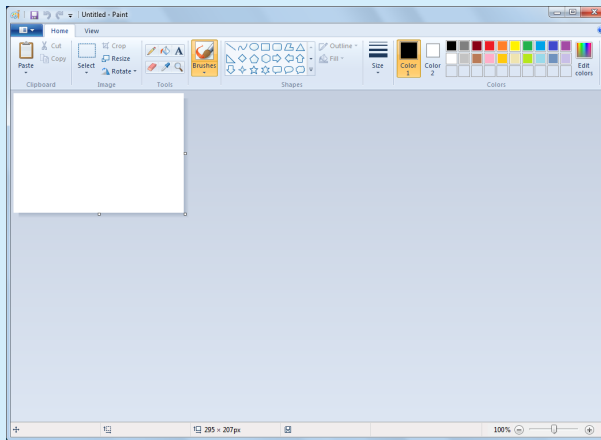

2. Open an image for color matching in “Paint.”

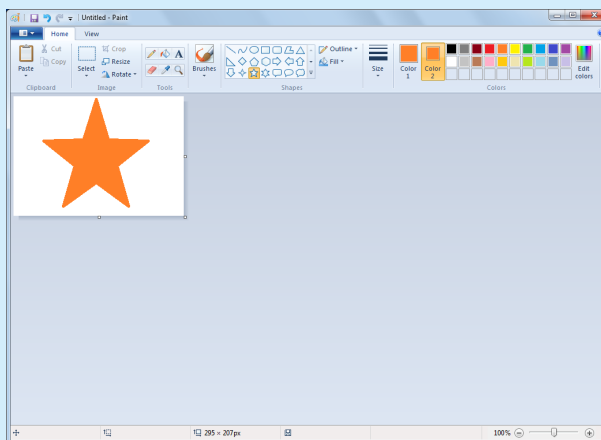

3. Click the image with the [Eyedropper] tool.

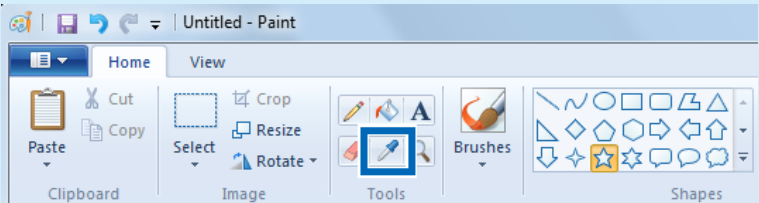

4. Next, click [Edit Colors].

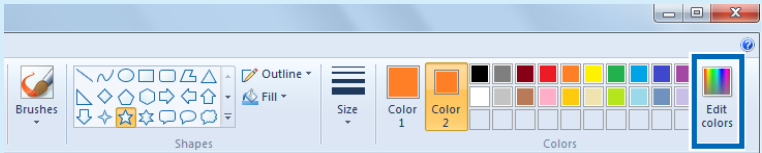

5. [Color/Pure Color] displays the colors captured with [Eyedropper], with [Red/Green/Blue] serving as R/G/B values.

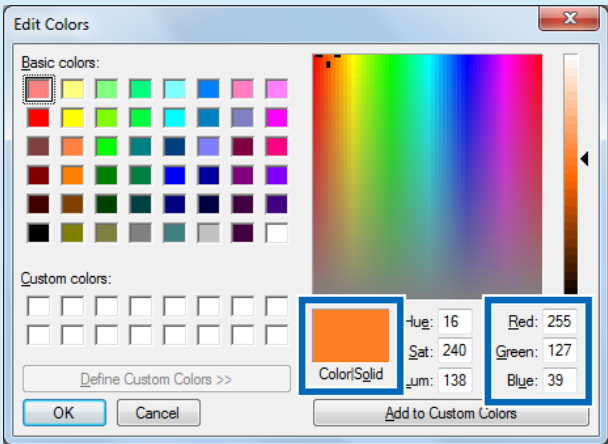

6. Enter the values of [Red/Green/Blue] into Red, Green and Blue in [Input Colors].

4

Enter the values of [Red/Green/Blue] into Red, Green and Blue in [Input Colors].

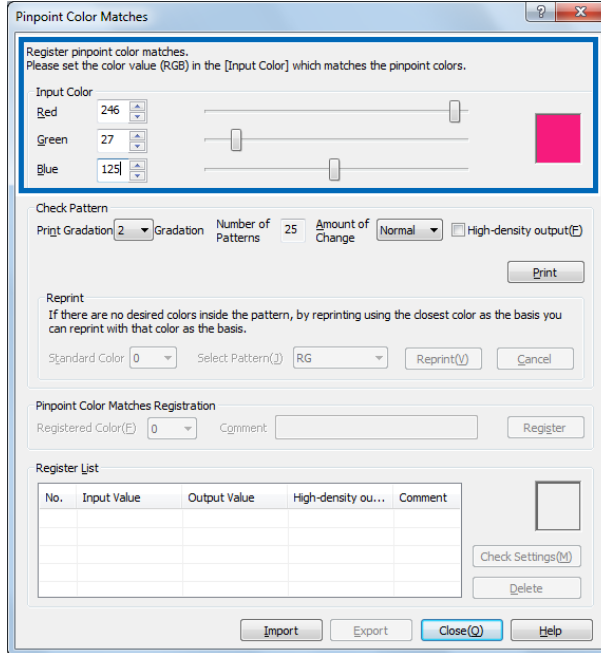

5

Print color pallets to designate color samples that represent approximate values 0 to 24.

Click [Print].

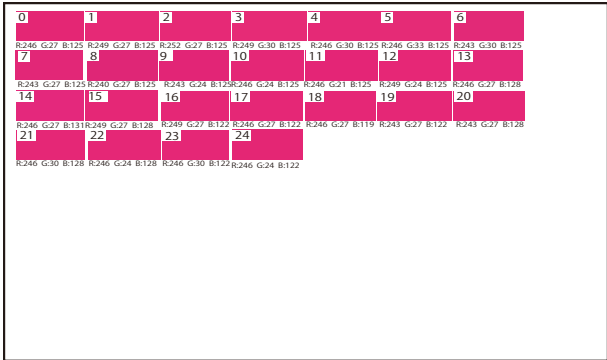
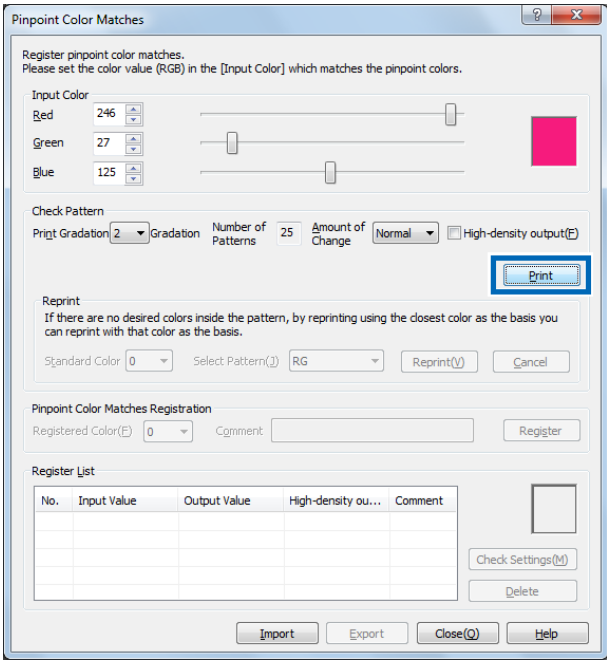

3. How to Use the Printer Driver

Note

- Before printing a color sample, checking the "High-density output" check box prints the color sample in deeper color.

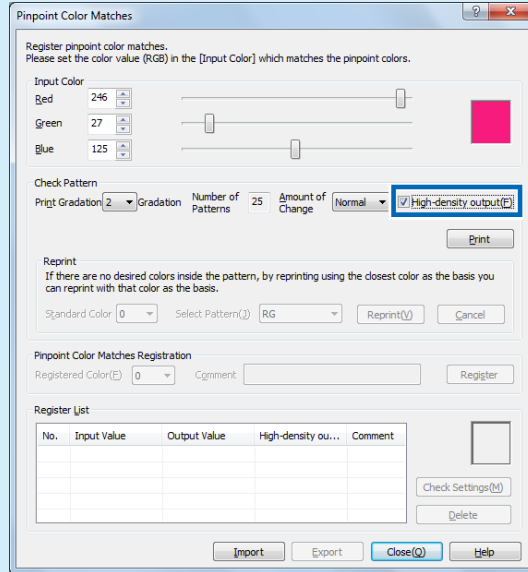

Note

- If the target color is not found, create a color close to it by performing [Reprint].

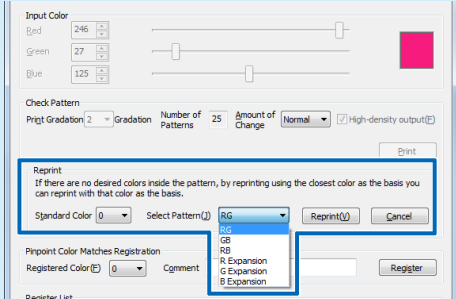

1 Enter the number of the color closest to the target color in [Base Color].

2 Select a color pattern in [Pattern Selection].

Select a color pattern by determining which of RGB needs to be enhanced with regard to the target color.

RG	Change the values of 2 colors, Red and Green, but not Blue.
GB	Change the values of 2 colors, Green and Blue, but not Red.
RB	Change the values of 2 colors, Red and Blue, but not Green.
R Expansion	Change the values of 3 colors across the board and then increase or decrease the value of Red.
G Expansion	Change the values of 3 colors across the board and then increase or decrease the value of Green.
B Expansion	Change the values of 3 colors across the board and then increase or decrease the value of Blue.

3 Click [Reprint].

4 If the target color is found in the color samples printed, select a number in [Registered Color] and click [Register].

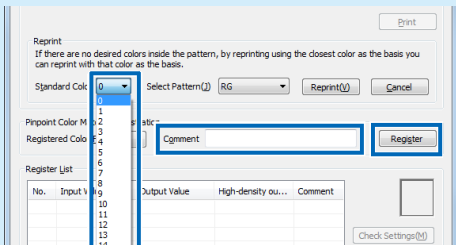

6

Check the printed color pallet and select the number of the color that is closest to "Input Color" from among 0 to 24, enter any name in the "Comment" field and click [Register].

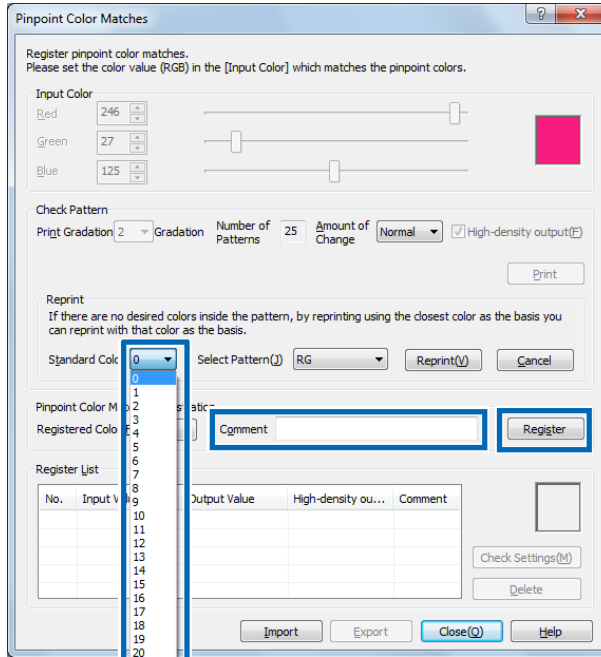

7

Displayed in the “Register List.”

Click the registered cell to preview it

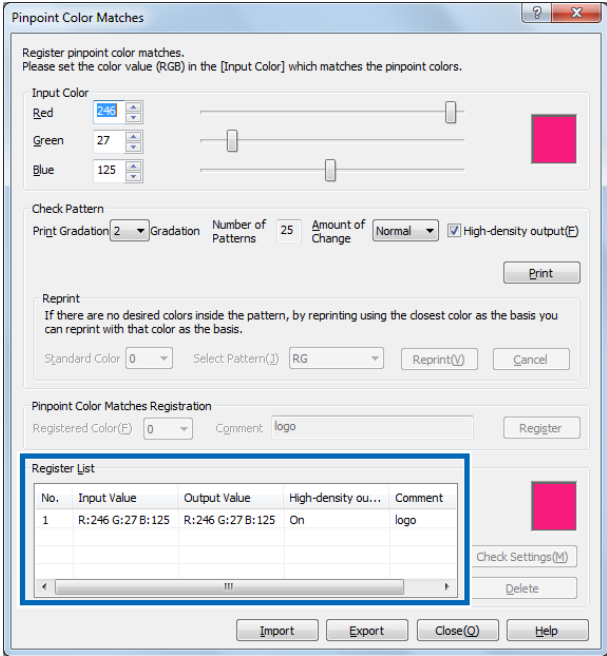

3. How to Use the Printer Driver

Note

- Use [Import] and [Export] to print created special colors on any other printer and to print special colors that have been created on any other computer.
- To check to see if a color has been registered or not, click [Printing Preferences]→[Color]→[Set Pinpoint Color Matches] and view [List of registered color].

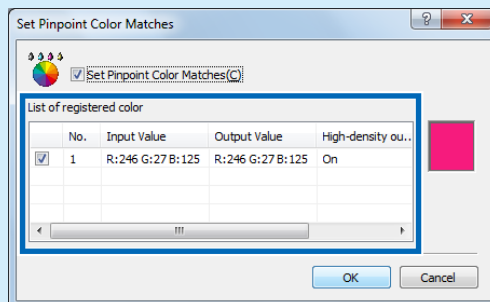
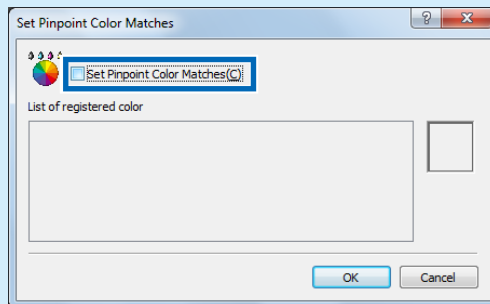
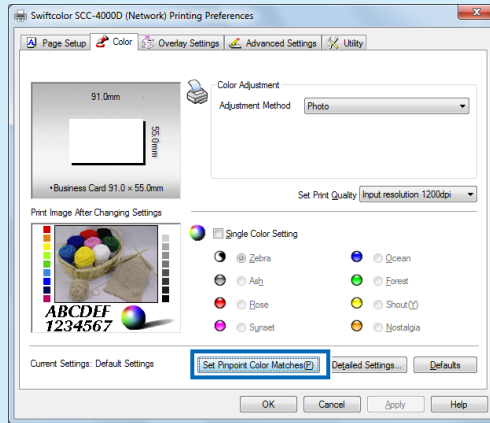

3-7-4. Special Settings

[Special Settings] is not necessary use. Set it when using the printer in an extraordinary environment or fanfold paper and so on.

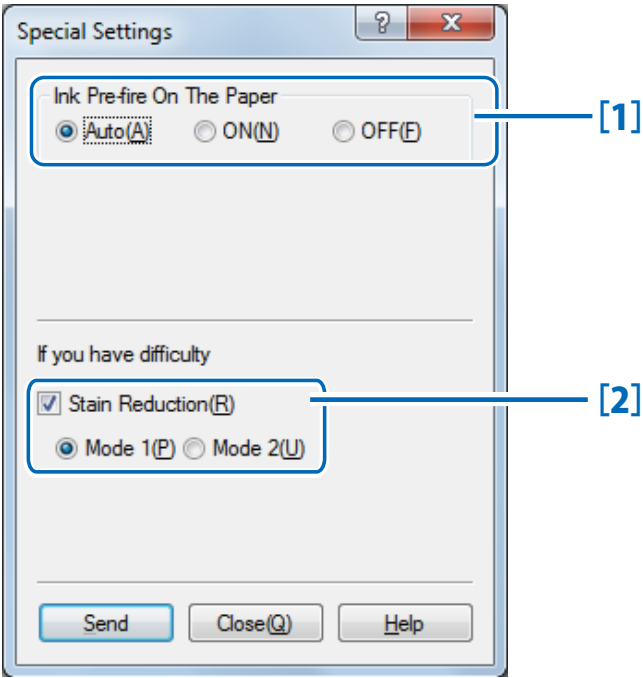

[1]	Ink Pre-fire On The Paper	Discharges negligible amounts of inks on the paper surface to keep the Printheads running at all times so that inks will not be stuck in the Printheads (nozzles) for unused colors, thereby preserving Printhead performance. The Auto is default.
	Auto	When the paper length is 95 mm or less, "Ink Pre-fire On The Paper" is not performed. When the paper length is 95.1mm or more, "Ink Pre-fire On The Paper" is performed.
	ON	"Ink Pre-fire On The Paper" is performed irrespective of the paper length.
	OFF	"Ink Pre-fire On The Paper" is not performed. (Additional printhead cleaning operation will be made during printing when [Ink Pre-fire On The Paper] is "OFF", causing duration of the print longer.)

3. How to Use the Printer Driver

[2]	Stain Reduction	Reduces stains on the back of paper. (Select this mode when printing a high-density image.) Check this check box, and then check the “Mode 1” or “Mode 2” check box. By default, this check box is not checked.
	Mode 1	The paper suction force during paper transport is reduced and height of the printhead is increased.
	Mode 2	The paper suction force is further reduced compared to Mode 1.

Note

- [Special Settings] cannot be set while printing is in progress or an error persists.

Important

- If a warning is issued when you press the [Special Settings], refer to the following:

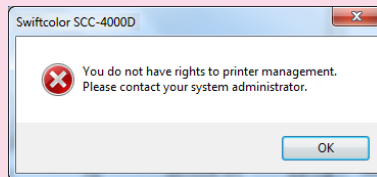

→ To perform the above-mentioned operation using an authority other than the Administrator privilege (P.93)

1

 Click [Special Settings].

[Special Settings] dialog box appears.

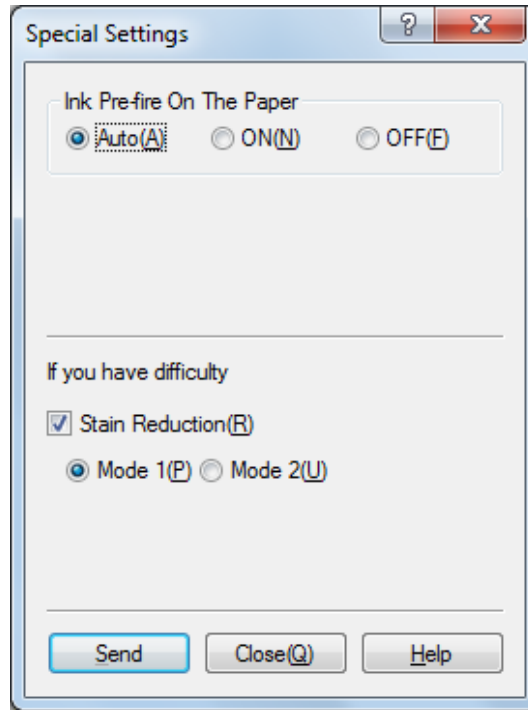

2

 Click the [Special Settings] to use and select or deselect them.

3

 Click [Send].

The confirmation dialog box appears.

4

 Click [Yes].

The settings are transmitted to the printer to take effect.

5

 Click [Close].

3-7-5. Add Custom Paper Type

Up to 10 custom paper types can be added, and ink jetting amounts can be set for respective paper types.

1 Click [Add Custom Paper Type].

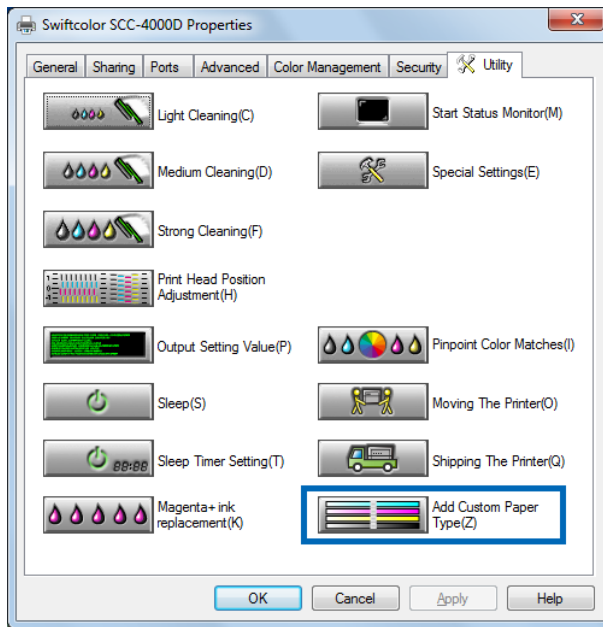

2 The [Add Custom Paper Type] dialog appears.

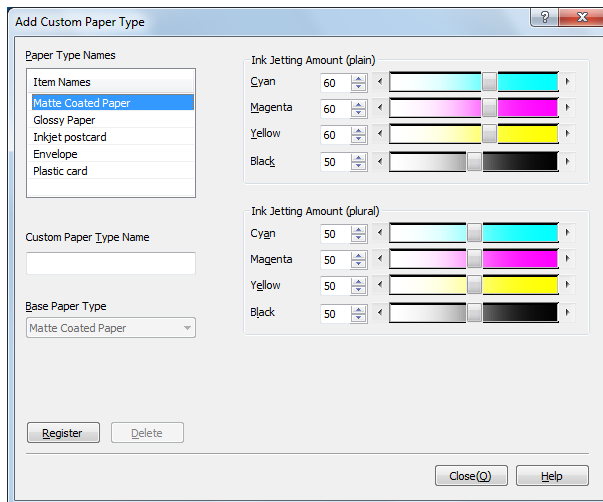

3

Type a desired name in the [Custom Paper Type Name] textbox.

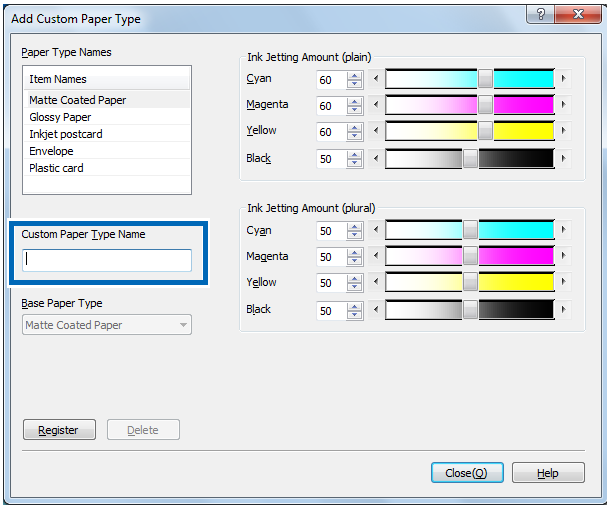

For example, type "User 1" as a desired name.

4

After typing a desired name, click [Register].

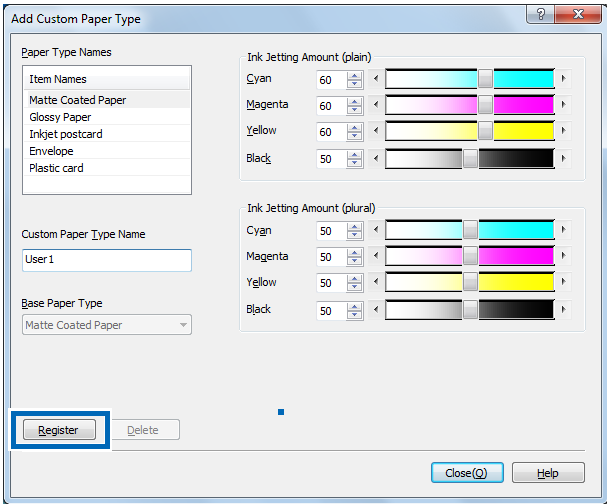

When a confirmation window appears, click [Yes].

5

“User 1” has been registered.

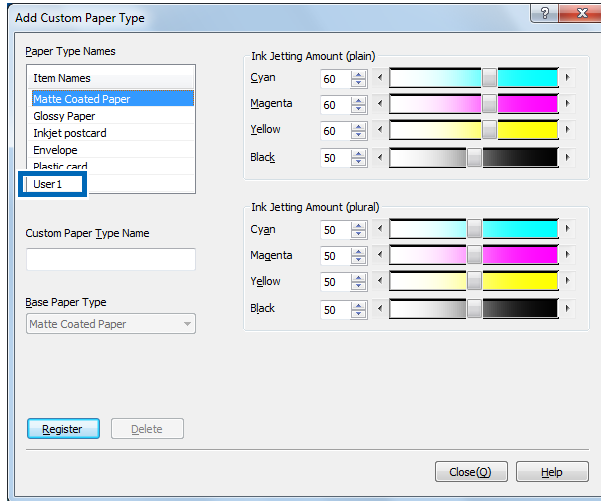

6

Select [User 1], and then select a paper type from [Base Paper Type].

Select from [Matte Coated Paper], [Glossy Paper], [Inkjet Postcard], [Envelope] and [Plastic card].

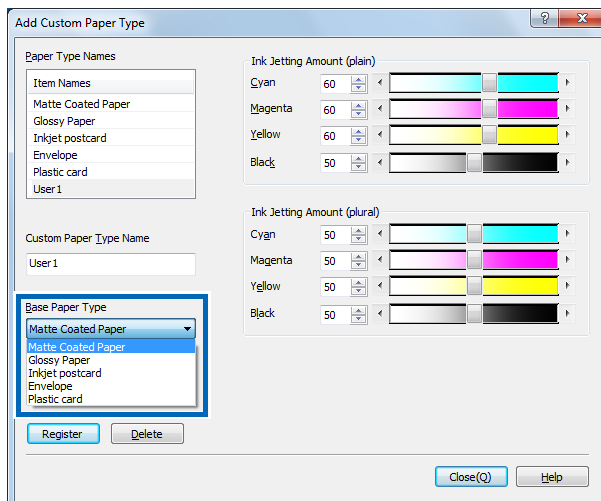

7

After selecting a paper type, set ink jetting amounts for respective colors.

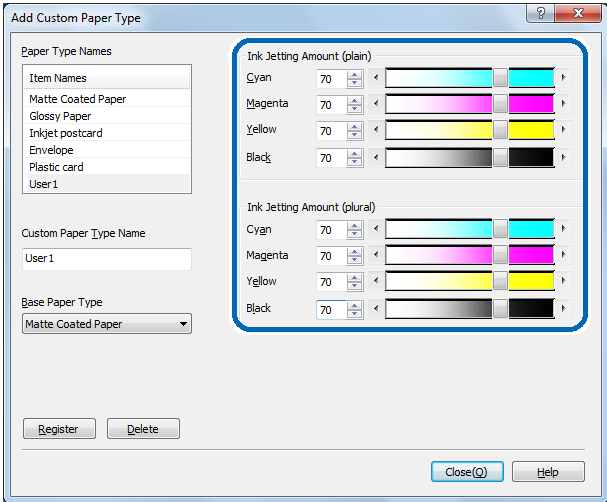

Important

- Moving the slide bar to the left decreases the ink jetting amount, and moving the slide bar to the right increases the ink jetting amount.
- Determine the ink jetting amounts optimum for the selected type of paper after conducting the print test several times.

8

Click [Register].

Thus, registration is completed.

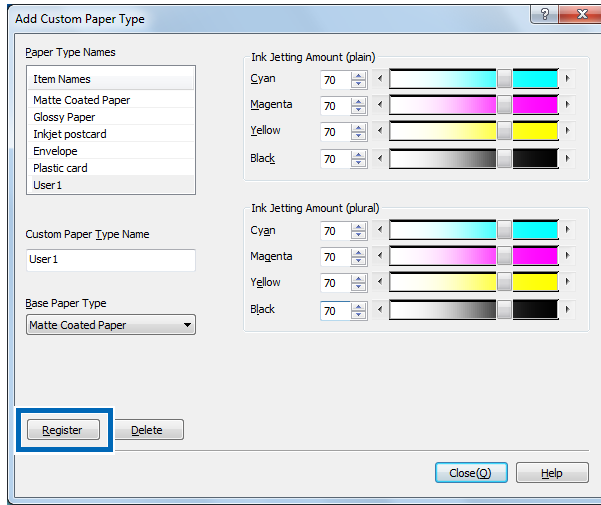

9

The registered paper type can be confirmed by selecting [Printing Preferences] → [Paper Type] of the printer driver.

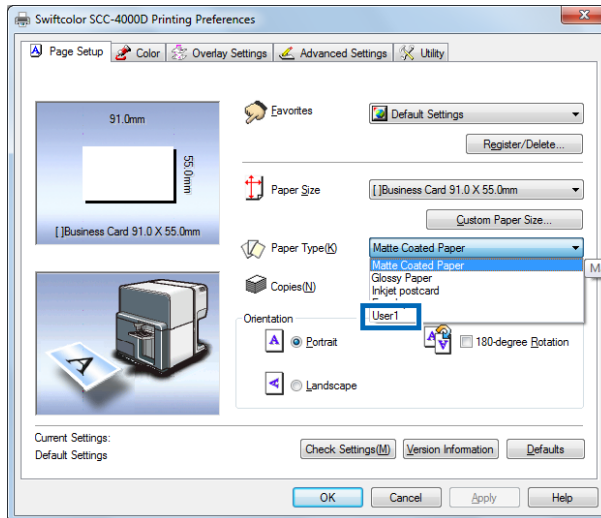

4. How to Use the Status Monitor

Use the Status Monitor to monitor the status of the printer and status of print jobs in progress.

4-1 Displaying the Status Monitor

This section describes how to start and display the Status Monitor.

4-1-1. Starting the Status Monitor

Follow the procedure below to start the Status Monitor.

Note

- With default, Status Monitor starts automatically every time a print job starts.
- You can also start the Status Monitor as soon as Windows starts up by selecting the specific function in a menu.
- You can store the Status Monitor normally in the taskbar or the task tray and display it only when an error occurs.

➔ [4-1-2. How to Start and Display the Status Monitor \(P.121\)](#)

1

Display the [Utility] sheet in the Swiftcolor SCC-4000D Properties dialog box then click Start Status Monitor.

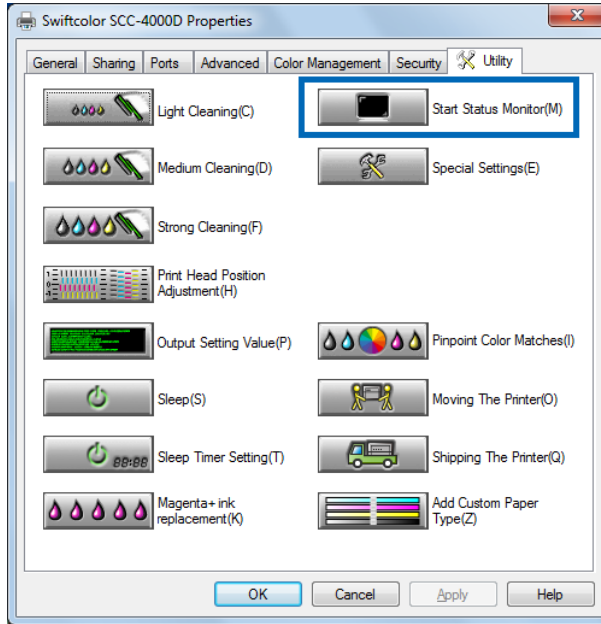

2

The Status Monitor starts.

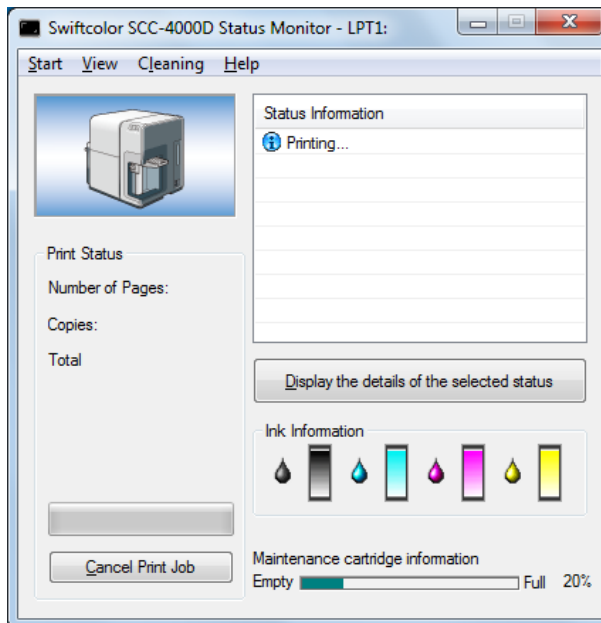

4-1-2. How to Start and Display the Status Monitor

The method to start and display the Status Monitor can be set.

■ Start Options

Use either method described below to set the start method.

[Start During Printing]

The Status Monitor automatically starts and displays when a print job starts.

The Status Monitor closes automatically when the print job ends. (This is the default setting.)

[Start With Windows]

The Status Monitor starts when Windows starts.

1

Open the Start menu and select the desired start option.

Click either Start During Printing or Start With Windows. A dot symbol (●) marks the currently selected item.

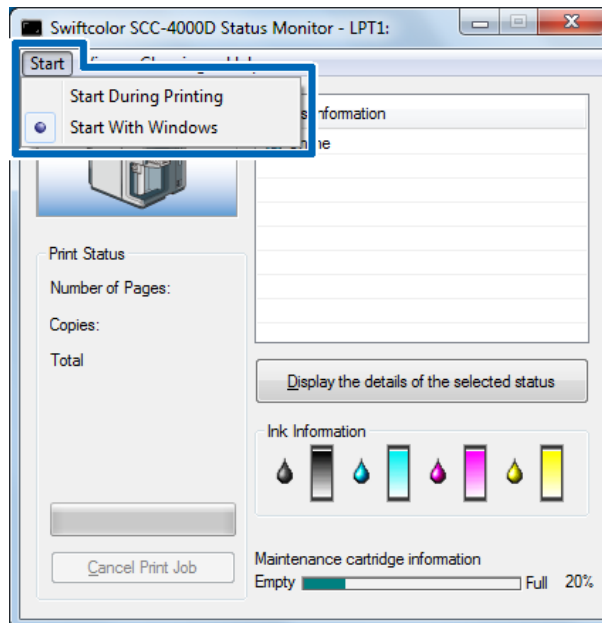

■ View Options

Use one of the methods described below to set the display method.

[Start With Popup]

Open and display the Status Monitor window. (This is the default setting.)

[Minimize at Start]

Minimize and store the open Status Monitor window on the taskbar.

[Start at Task Tray]

Create an icon for the open Status Monitor window and stores the icon in the task tray.

[Always Show on Top]

Always display the open Status Monitor window in the foreground even when the windows of other software applications are open.

1

Open the View menu and select the desired option.

Click Start With Popup, Minimize at Start, or Start at Task Tray. A dot symbol (●) marks the currently selected item.

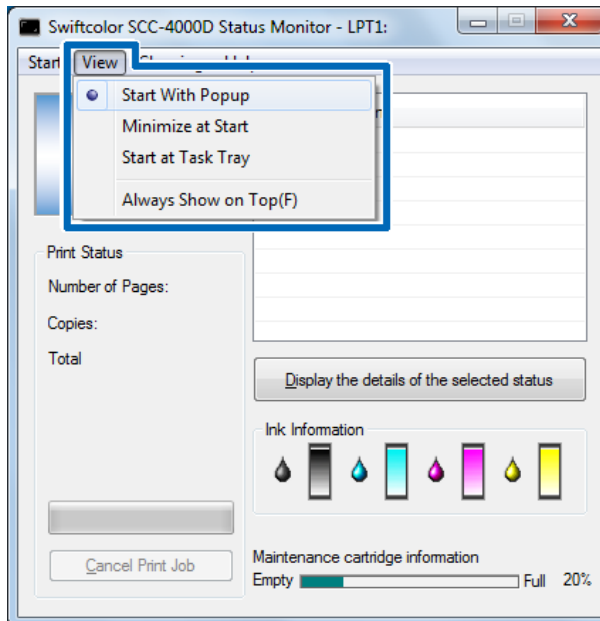

Note

- If you want the window to display always on the top, click Always Show On Top by attach the checkmark at the beginning of the name of this selection. This setting has no connection with the other settings on the View menu.
- If you select Always Show on Top, the Status Monitor will appear semi-transparent on the screen.
- Even if you select Minimize at Start or Start at Task Tray, the Status Monitor will pop up and display a message when an error occurs. If you click the minimize button in the pop-up window, you can restore Status Monitor to the task bar.

4-2 Using the Status Monitor

Use the Status Monitor to not only monitor the status of print jobs in progress but also monitor the status of the printer and the level of the ink supply and quantity of ink collection of the maintenance cartridge.

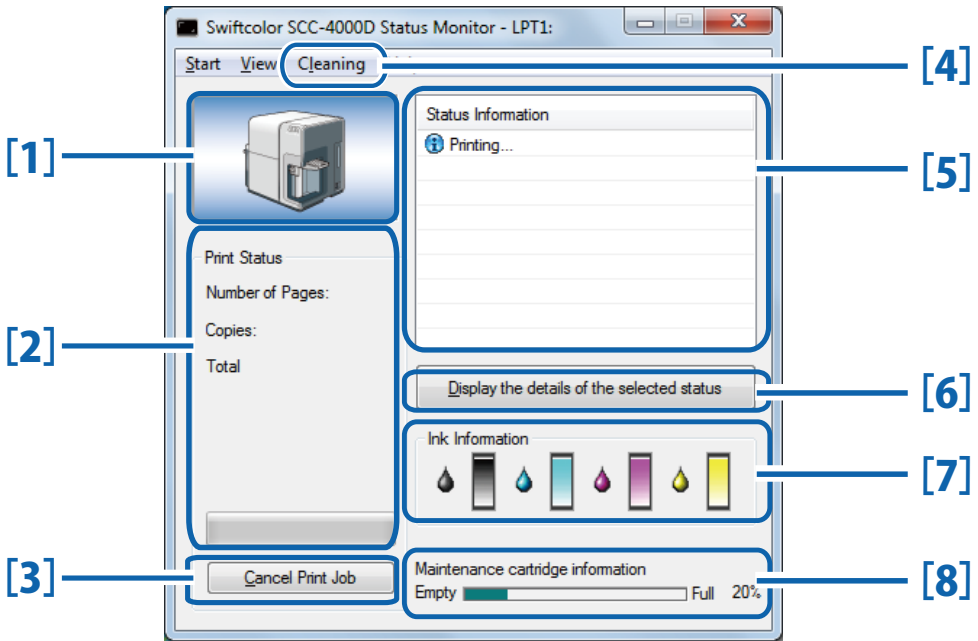

- [1] **Graphic image of the printer status**
Graphic image showing the current status of the printer.
- [2] **Print Status**
Current printing status will be displayed with numerical value and indicator ➔ 4-2-1. Viewing the Print Status (P.125)
- [3] **Cancel Print Job**
Cancel print job in progress.
- [4] **Cleaning**
This option is only effective when the Pause key of the printer is pressed for temporary stop. ➔ 2-3-2.Cleaning During Temporary Stop (P.31)
- [5] **Status Information**
Messages to inform you about the current status of the printer. ➔ 4-2-2. Viewing the Printer Status (P.127)

[6] Display the Details of the Selected Status

Open a separate window to display more information about the status of the printer.

[7] Ink Information

Display the amount of ink remaining.

➔ [4-2-3. Viewing Ink Information \(P.131\)](#)

[8] Maintenance Cartridge Information

Display the amount of ink collected in the maintenance cartridge.

➔ [4-2-4. Viewing Maintenance Cartridge Information \(P.133\)](#)

4-2-1. Viewing the Print Status

Progress of printing can be checked.

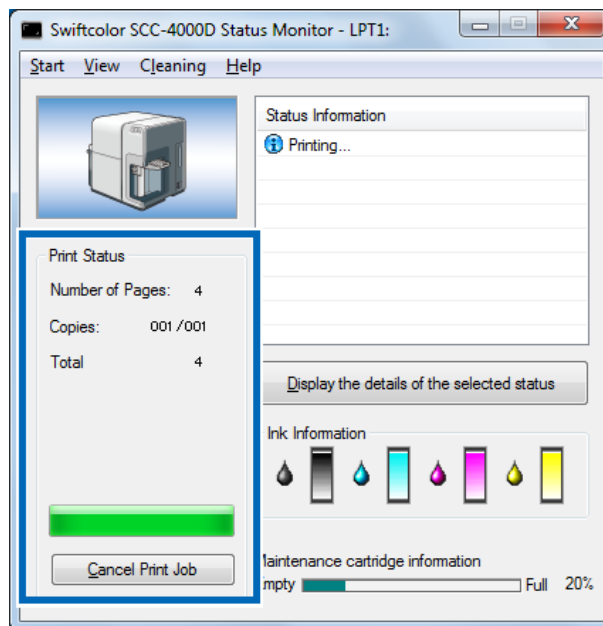
**[Number of Pages]**

Displays the number of pages of the document specified for printing.

[Copies]

The status of printing of the specified number of copies in progress appears.

4. How to Use the Status Monitor

For example, If the printing of a three-page document in 10 copies is set, “0001/0010” to “0010/0010” appears while the first page is printed. The progress bar represents the status of printing of the number of copies by page in progress.

[Total Copies]

A total count of the specified number of copies printed appears.

[Cancel Print Job]

Click to cancel a print job in progress. The printer stops after the current print job is completed.

Note

- If the print job does not stop even after clicking [Cancel Print Job], press the power key for at least 1 second.

4-2-2. Viewing the Printer Status

Use these features to monitor the status of the printer.

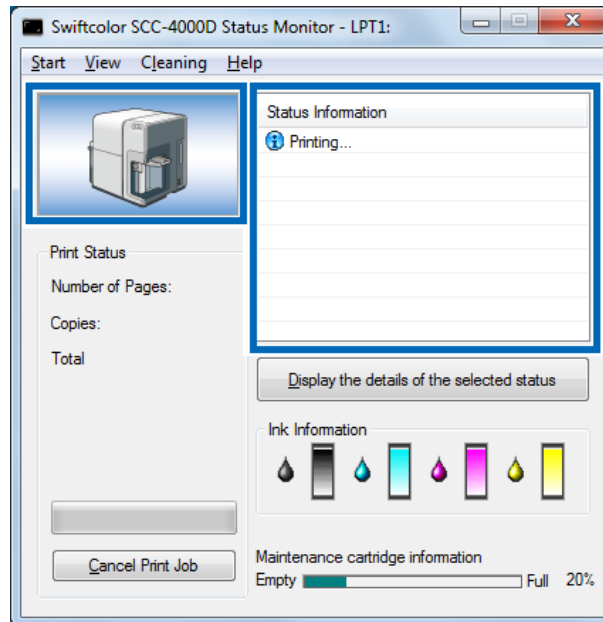

There are Four types of images to keep you informed about the status of the printer.



Displayed to indicate the normal mode. (Background is blue)
The printer is in the online mode and ready to print.

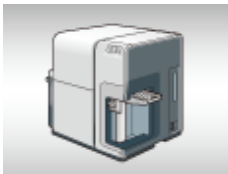

Displayed when a Offline has been issued. (Background is gray)



Displayed when a warning has been issued. (Background is yellow)
A warning message is displayed for the Status Information but printing can continue. Troubleshoot the problem as required.



Displayed when a error has been issued. (Background is red)

An error message is displayed for the Status Information, and printing cannot be done in this status. Troubleshoot the problem as required.

Note

- If the Status Monitor has been minimized, or if it has been placed in the task tray, the Status Monitor will open only when an error occurs.

■ Viewing the Status Information

The Status Information indicates the status of the printer by displaying the following four icons and messages.



Information

Display printer related information. Please confirm the content of the messages displayed here.



Warning message

Indicate that a warning is being issued for a problem occurred. Read and confirm the content of the message. Printing continues.



Operator Call Error

These errors are issued for a problem that requires your attention. Confirm the content of the message, and follow the required troubleshooting procedure.



Fatal Error

These errors are issued for problems that cannot be solved by the user. Please turn the main power switch off. If the error occurs again after switching the printer off and on, make a note of the 4-digit error code, and look for the error code in the troubleshooting section (or any place where the error code is), and to perform troubleshoot by following the instruction. If the error code still appears after troubleshooting, contact dealer.

Note

- If several errors occur at the same time, the most important error is displayed on the top of the list.

After you read the message displayed in the Status Information, follow the procedure below if you want to open another window to learn more details.

1

Select the message to read, and click the [Display the details of the selected status] button.

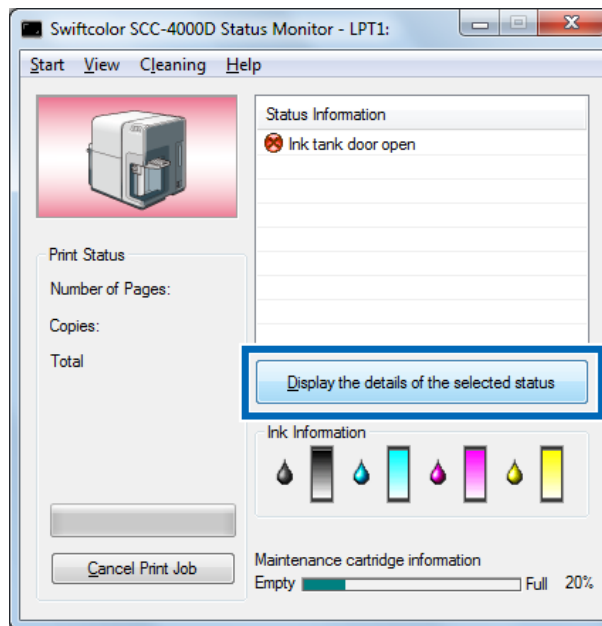

The description window opens and displays a description of the message and provides some troubleshooting advice.

4. How to Use the Status Monitor

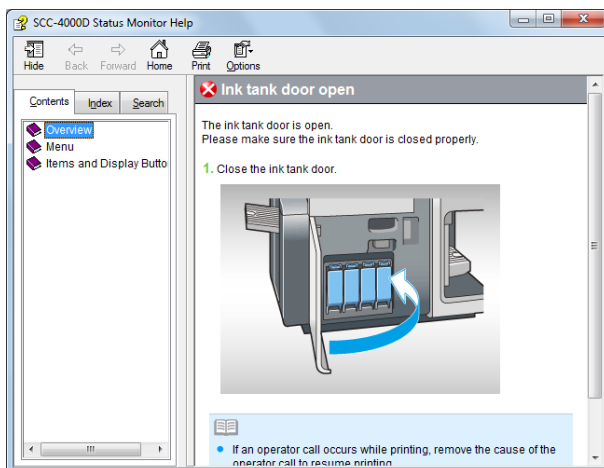

Note

- You can also double-click the item in the Status Information list to open the same information window.

4-2-3. Viewing Ink Information

Use these features to monitor the level of the ink in the ink tanks.

There are four colors of ink tanks; Black (BK), Cyan (C), Magenta (M), and Yellow (Y) .

Icons are used to indicate the level of ink in each ink tank.



Remaining ink level : Ink Full

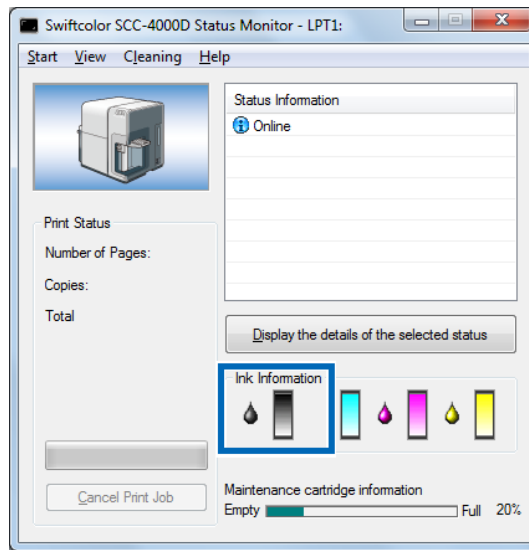

Remaining ink level : Less than about 20%

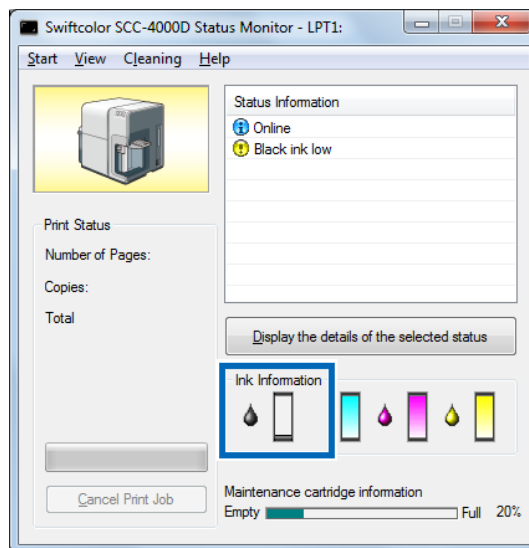

4. How to Use the Status Monitor

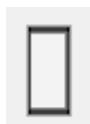

Empty

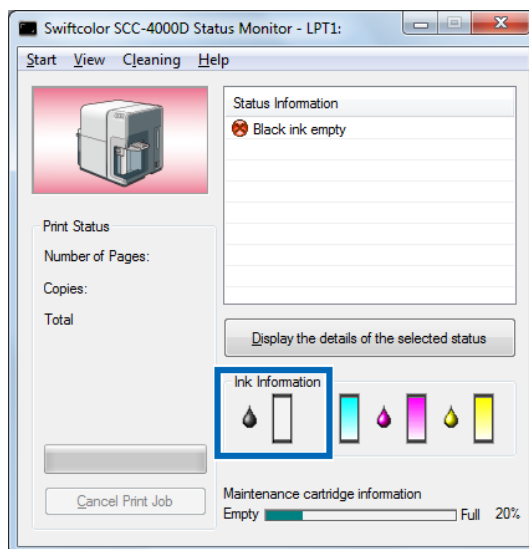

➔ 5-5 Replacing Ink Tanks (P.152)

Important

- Do not remove an ink tank unless you must replace it. This could shorten the life of the consumable.
- When replacing an ink tank, do not leave the printer without an ink tank for long periods of time.

Note

- If "XXXX ink low" is displayed, prepare a new ink tank before "Out of XXXX ink" is displayed, and replace the tank. For how to get a new ink tank, contact the dealer.

4-2-4. Viewing Maintenance Cartridge Information

Use this feature to monitor the amount of the ink collected in the maintenance cartridge.

Note

- The maintenance cartridge is used to collect the ink used for printhead cleaning, etc.
- The [Maintenance Cartridge Level] indicator at the bottom of the [Status Monitor] dialog box indicates the space currently left in the maintenance cartridge.

[Maintenance cartridge near full]

When the space left in the maintenance cartridge becomes 20%, a message, "Maintenance cartridge near full," is displayed in the [Status Information] field.

Note that printing continues without interruption.

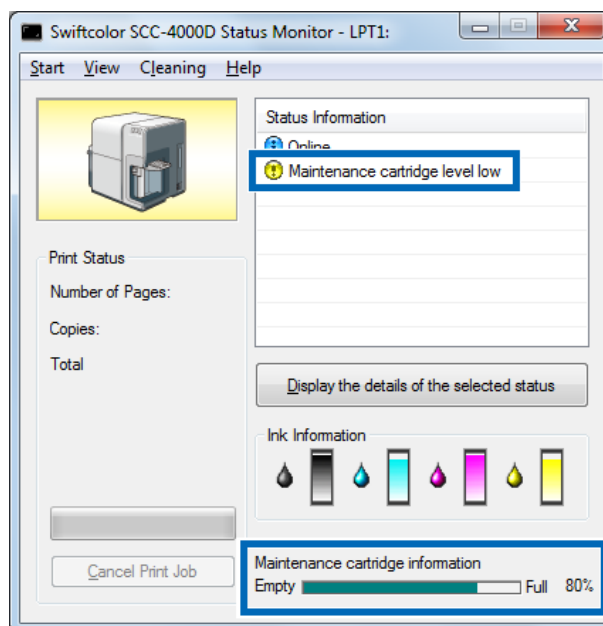

[Maintenance cartridge full]

When there remains no maintenance cartridge space to collect ink, a message, “Maintenance cartridge full,” is displayed and printing stops after finish printing the on going job. When this message appears, replace the maintenance cartridge with a new one.

➔ [5-7 Replacing the Maintenance Cartridge \(P.160\)](#)

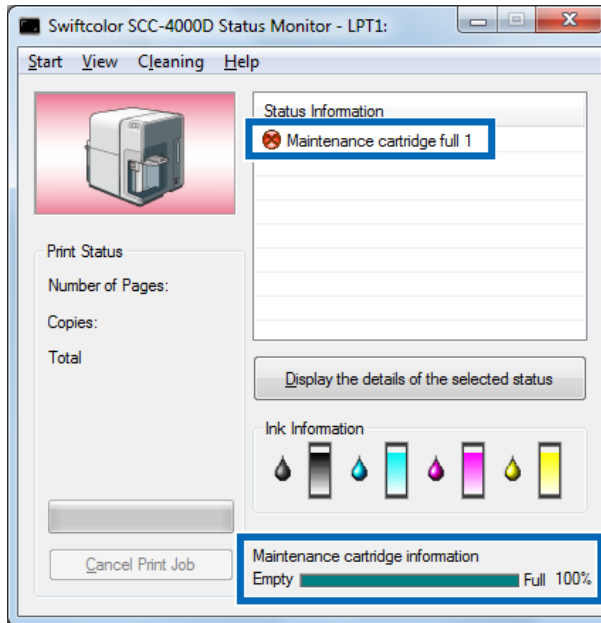

5. Printer Maintenance

This chapter describes how to maintain the printer and keep it in good operating condition.

5-1 Cleaning the Printhead

If your prints appear faint, this could mean that dust and paper dust have clogged the printhead. Clean the printhead to clear clogged nozzles.

5-1-1. Cleaning

Clean the clogged Printhead nozzles.

Select light, medium, or strong cleaning according to the printing result.

Light Cleaning	Recovery operation performed first when printhead nozzle clogging occurs. (Repeat this operation as required.)
Medium Cleaning	Recovery operation performed when printhead nozzle clogging occurs even after light cleaning is performed. (Repeat this operation as required.)
Strong Cleaning	Recovery operation performed when printhead nozzle clogging occurs even after Medium cleaning is performed. (Repeat this operation as required.)

Note

- During cleaning is in process, do not perform any other operation.
- Cleaning cannot be done during a print job or when an error is occurring.
- If Strong cleaning fails to solve the problem, the printhead may require replacement, or there could be some other problem. Contact your local dealer or call the Tech support.
- Please remember that cleaning consumes ink. Clean the printhead only when necessary.

1

Open the [Utility] sheet in the [Swiftcolor SCC-4000D Properties] dialog box, select [Light Cleaning], [Medium Cleaning] or [Strong Cleaning] and click it.

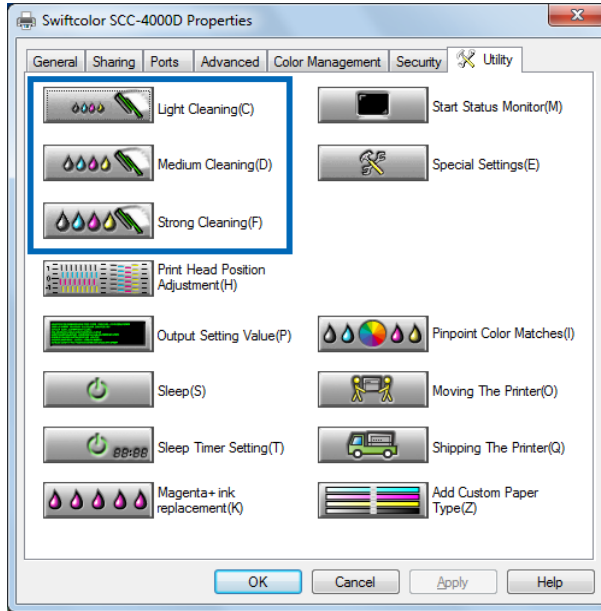

The confirmation dialog box appears.

2

Click [Yes].

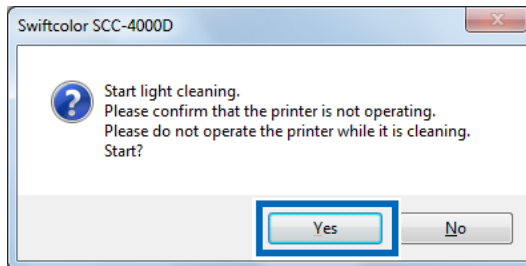

The cleaning begins.

5-2 Adjusting the Printhead Position

Although the printer has already been adjusted for optimum performance upon installation, please adjust printhead position if you experience unexpected colors or other problems in your print results.

The printhead adjustment procedure consists of printing a Printhead Position Adjustment Pattern, reading the pattern, and then making some simple adjustments to change the position of the printhead.

Important

- Adjustment patterns change depending on the size of the paper being set to printer, although the adjustment method is the same.
- The printhead adjustment cannot be done while the printer is printing or after an error has occurred.
- If a warning is issued when you press the [Adjusting the Printhead Position], refer to the following:

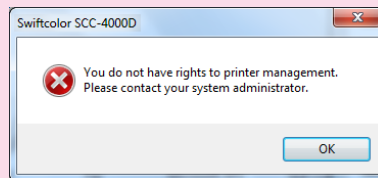

→ <To perform the above-mentioned operation using an authority other than the Administrator privilege.> (P.93)

1

Opening the [Utility] sheet in the [Swiftcolor SCC-4000D Properties] dialog box and click [Printhead Position Adjustment].

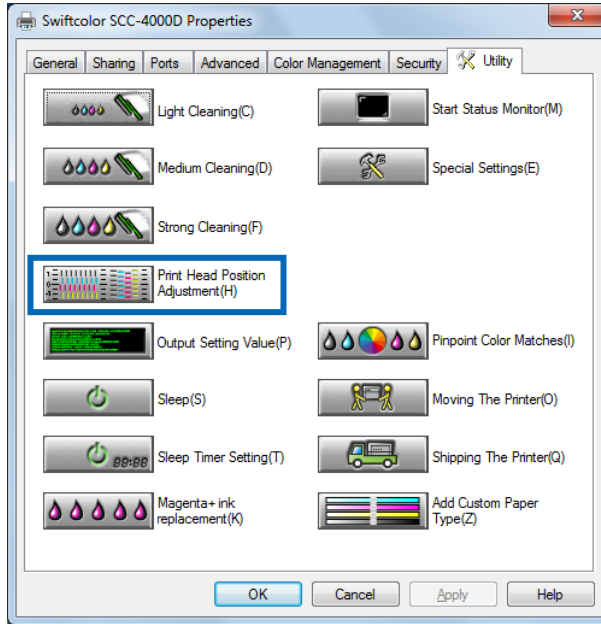

2

The [Printhead Position Adjustment] dialog box appears.

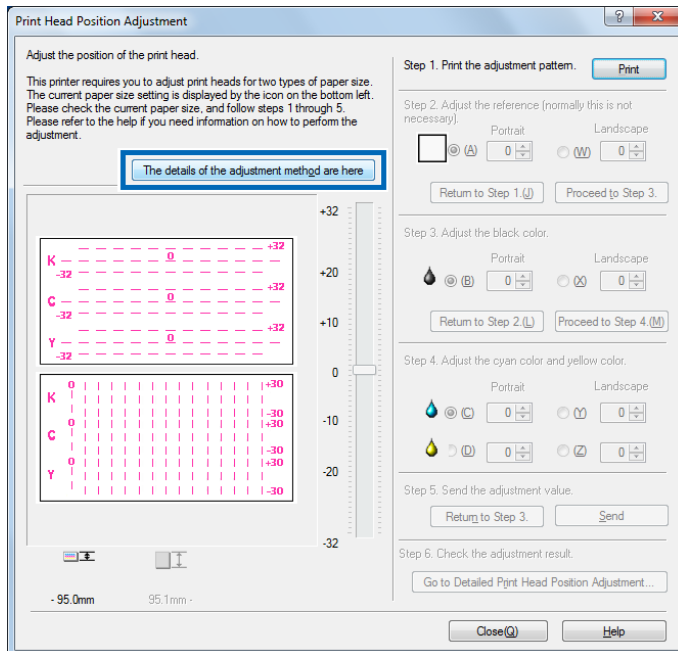

Click “The details of the adjustment method are here” to view operating procedures from [Help].

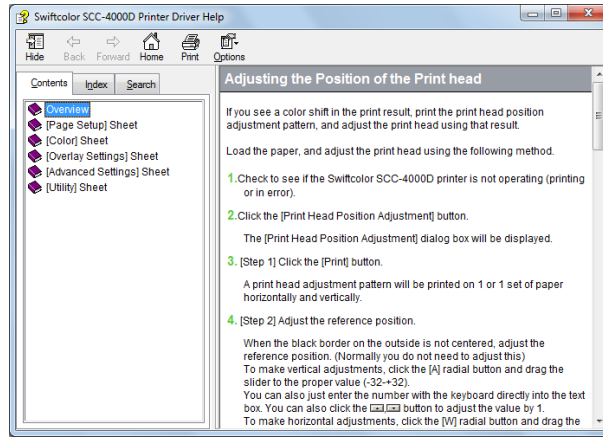

3

Check that the printer is not running and perform Step 1 “Print the adjustment pattern.”

Click [Print].

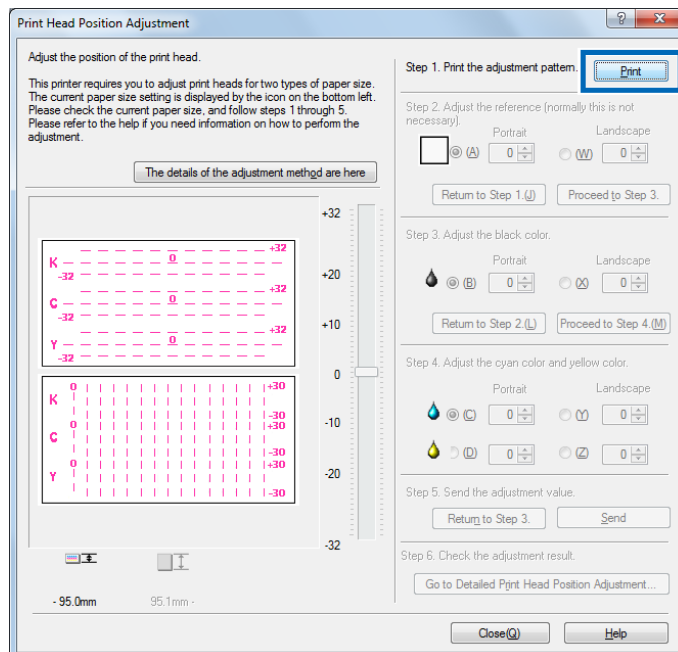

4

When the confirmation window appears, click [Yes].

An adjustment pattern is printed.

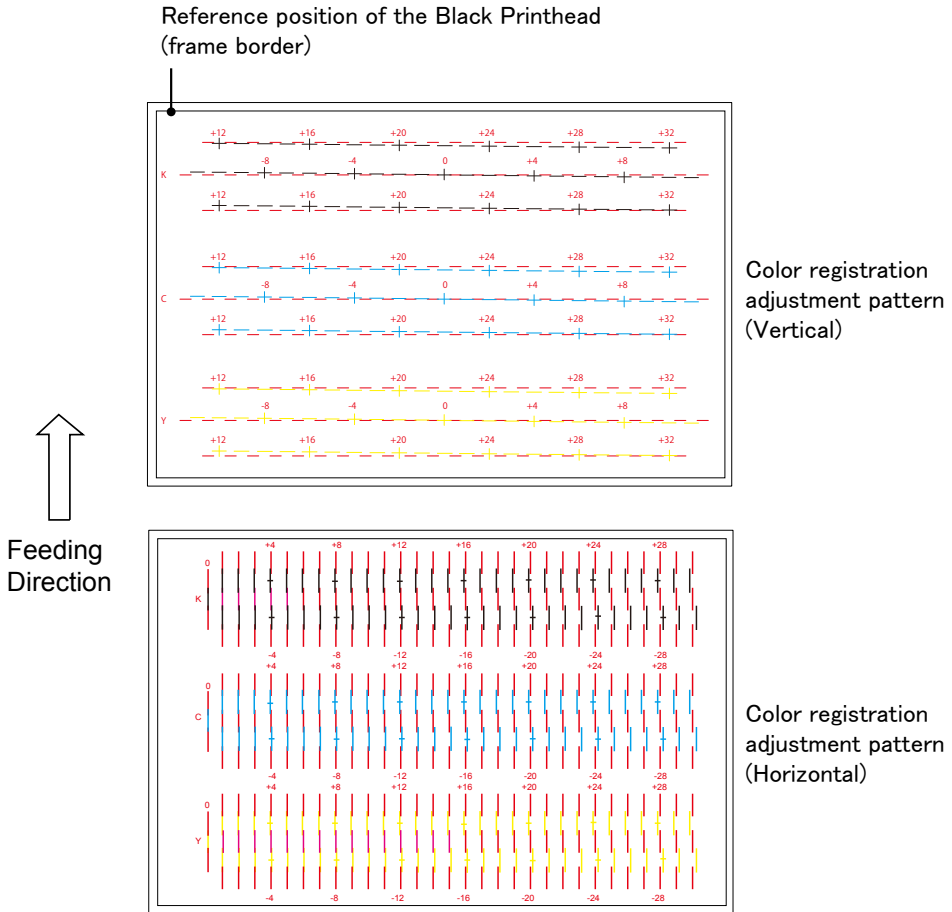

5

The confirmation window appears for you to check to see if the adjustment pattern has been printed correctly or not.

Click [Yes].

Clicking [No] prints the adjustment pattern again.

6

On confirming successful printout, click [Proceed to Step 3].

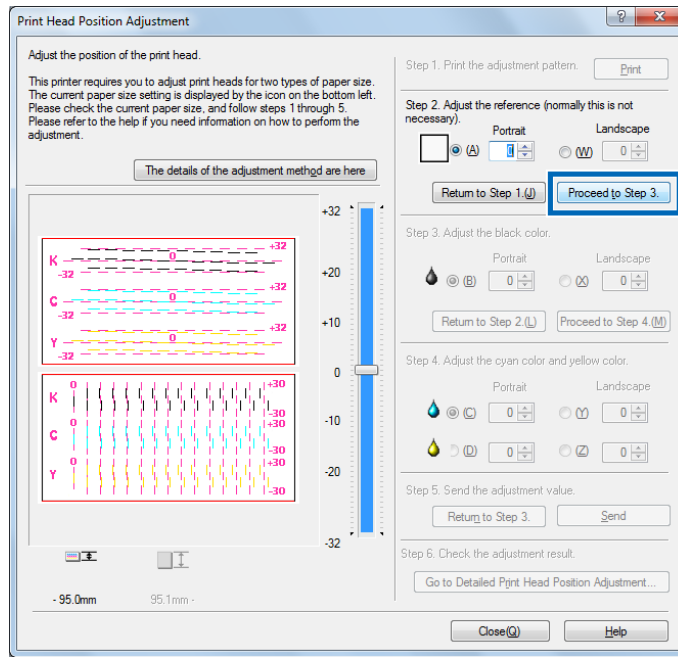

Note

- [Step 2] covers the procedure for adjusting the reference position of the Black Printhead (frame border), but it normally does not require changes.
 - The reference position can be identified from a frame border drawn in the circumference of the Printhead position adjustment pattern. Normally, this frame border is drawn 2.0 mm above the top end of the paper and 2.0 mm from the leftmost end. It should require adjustment if it is found significantly out of position.

Note

- Step 2 Adjust the reference position of the Black Printhead (frame border)





■ **Adjusting the Vertical Direction**

If the Black border for K (Black) reference position adjustment is shifted upward, set the value to negative (-). If it is shifted downward, set the value to positive (+). Click [A] (Black) in [Vertical Direction] and drag the slider in the middle to increase or decrease the value.

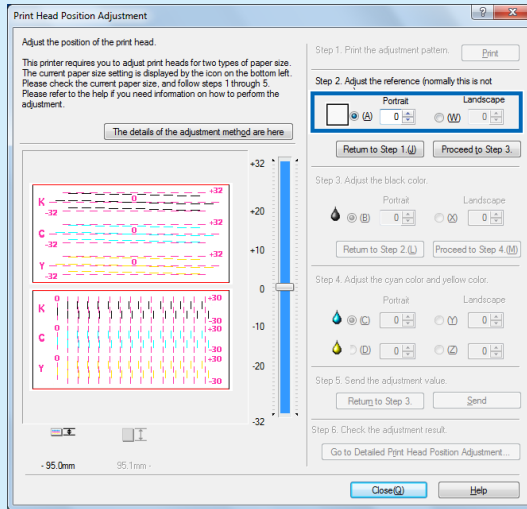
■ **Adjust the Horizontal Direction**

If the Black border for K (Black) reference position adjustment is shifted leftward, set the value to positive (+). If it is shifted rightward, set the value to negative (-). Click [W] (Black) in [Landscape Direction] and drag the slider in the middle to increase or decrease the value.



- A value can be entered in the entry box from the keyboard after clicking the entry box.
- Click the  ,  and buttons to increment and decrement the current value by one.
- As the value is incremented or decremented by one, the Black border moves to the left or right by 0.0212 mm.
- The vertical adjustment range is [-32 to +32] and the horizontal adjustment range is [-30 to +30]; however, each value may not be selected within the overall range depending on the current setting. Select a value between the  mark and the  mark displayed on the slider scale.

7

Step 3. Adjust Black color.

Check [B] Vertical Direction and [X] Horizontal Direction in adjustment pattern [K] (Black) and read and enter the value at the point of their intersection with the Magenta line.

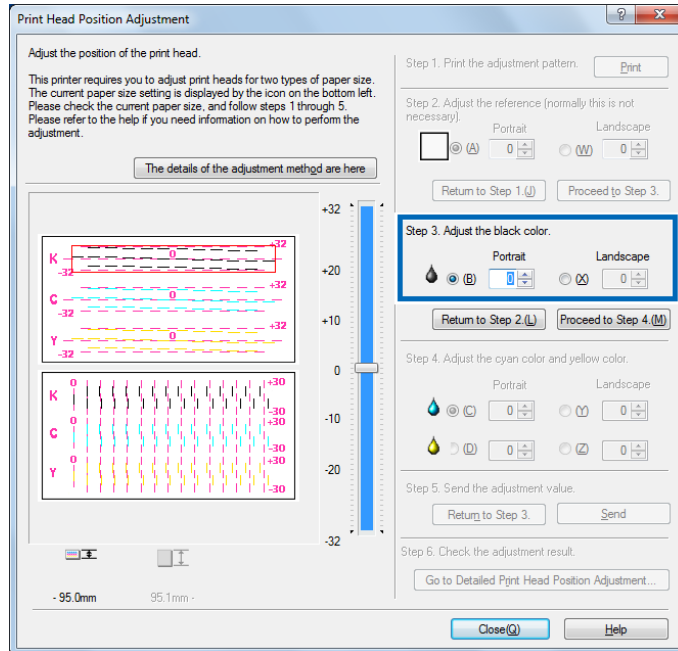
**Note**

- If [B] Vertical Position or [X] Horizontal Direction is selected, the visible point in the adjustment pattern in [Head Position Adjustment] dialog box is marked in a Red border.
- To review the last setting entered, click [Return to Step 2].

■ Adjust the Vertical Position

Read the value of the apparently smoothest (stepless) interconnection of the Magenta and Black lines in the head position adjustment pattern.

In the following case, for example, the adjustment value is "0":

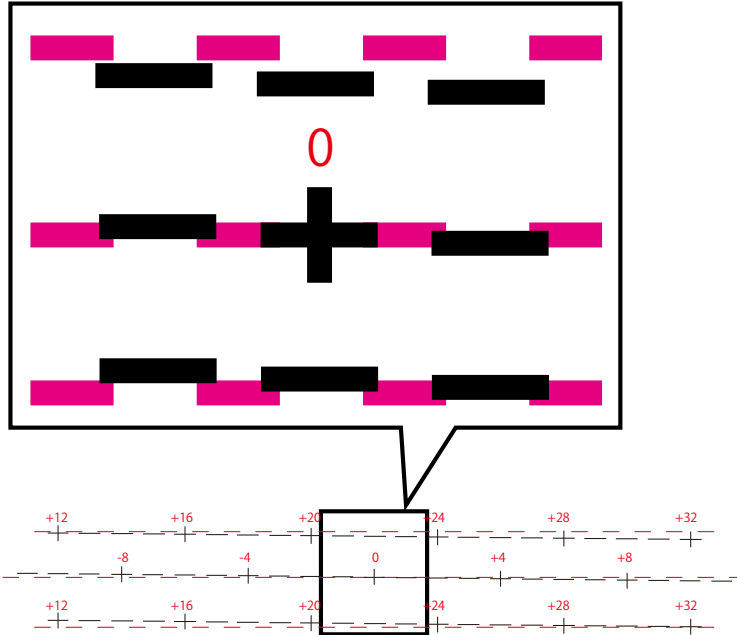

Check (B) in [Vertical Direction] in Step 3 in the [Head Position Adjustment] sheet and enter "0."

■ Adjust the Horizontal Position



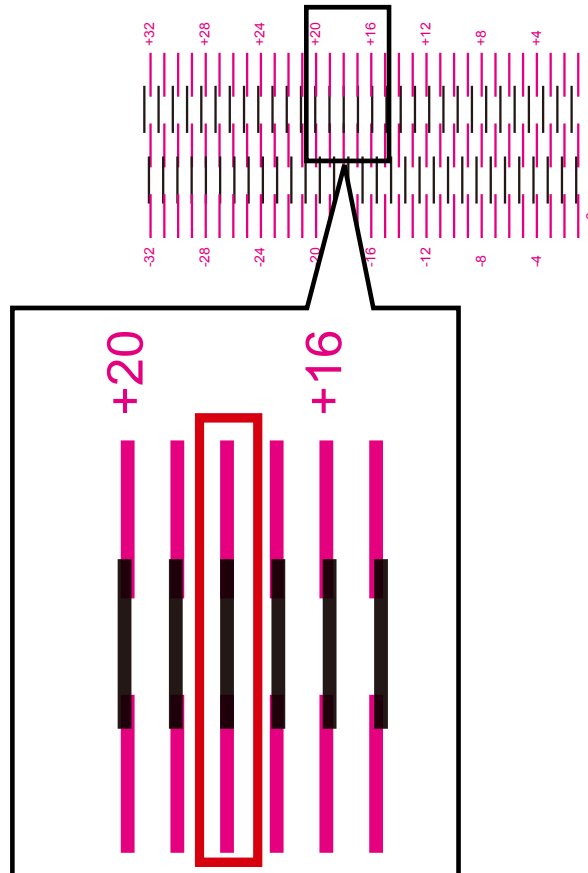

Read the value of the apparently smoothest (stepless) interconnection of the Magenta and Black lines in the head position adjustment pattern.

In the following case, for example, the adjustment value is “+18”:



Check (X) in [Horizontal Direction] in Step 3 in the [Head Position Adjustment] sheet and enter “18.”

Note

- Click the  , and  buttons to increment and decrement the current value by one.
- The vertical adjustment range is [-32 to +32] and the horizontal adjustment range is [-30 to +30]; however, each value may not be selected within the overall range depending on the current setting. Select a value between the  mark and the  mark displayed on the slider scale.

8

Having entered the adjustment value, click [Proceed to Step 4].

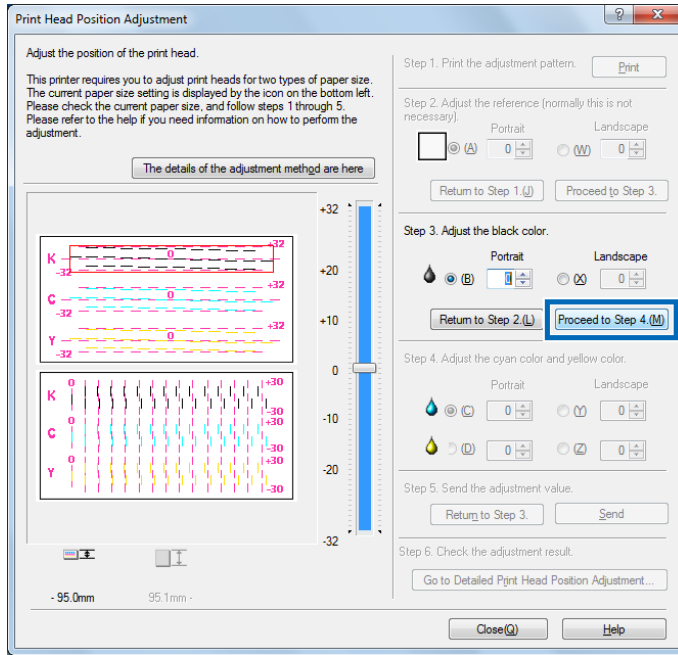

9

Step 4. Adjust Cyan and Yellow

Check [C] Vertical Direction and [Y] Horizontal Direction in adjustment pattern [C] (Cyan) and read and enter the value at the point of their intersection with the Magenta line.

Read adjustment pattern [Y] (Yellow) in the same manner. ([D] Vertical Direction, [Z] Horizontal Direction)

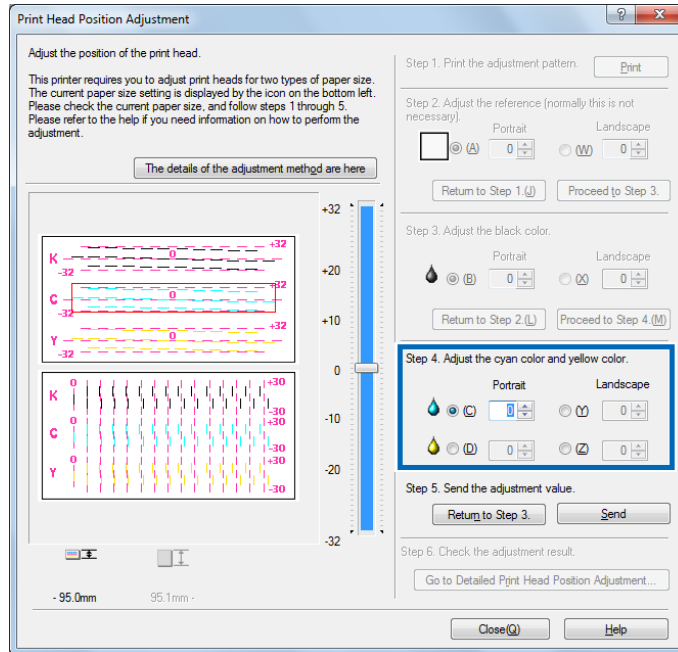
**Note**

- If [C] or [D] Vertical Direction or [Y] or [Z] Horizontal Direction is selected, the visible point in the left-side adjustment pattern is marked in a Red border.
- To review the last setting entered, click [Return to Step 3].

■ Adjust the Vertical Position

With regard to Cyan and Yellow, read the value of the apparently smoothest (stepless) interconnection of the Magenta and other colored lines in the Printhead position adjustment pattern.

In the following case, for example, the Cyan adjustment value is “+18”:

Adjust Yellow in the same manner.

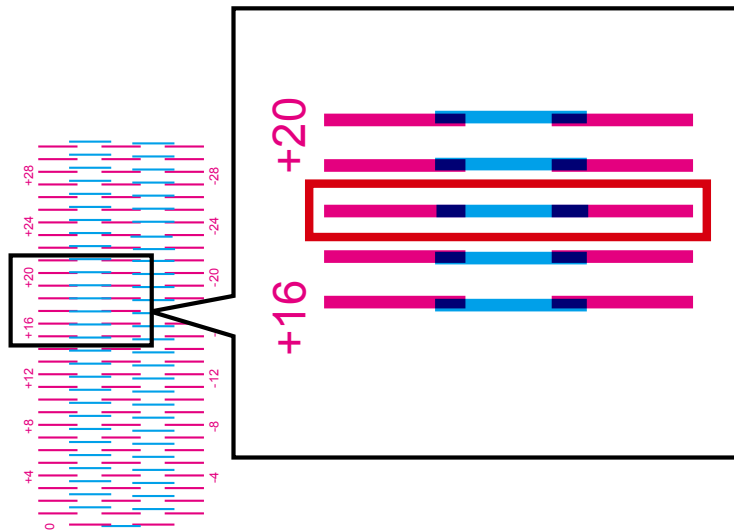

Check [C] or [D] in [Vertical Direction] in Step 4 in the [Head Position Adjustment] sheet and enter “18.”

■ Adjust the Horizontal Position

With regard to Cyan and Yellow, read the value of the apparently smoothest (stepless) interconnection of the Magenta and other colored lines in the Printhead position adjustment pattern.



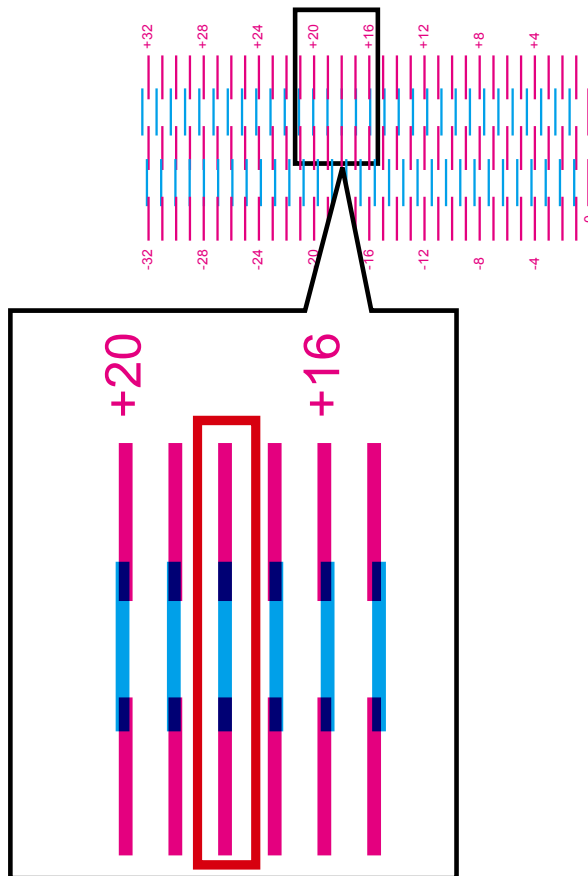

In the following case, for example, the Cyan adjustment value is “+18”:

Adjust Yellow in the same manner.



Check [Y] or [Z] in [Vertical Direction] in Step 4 in the [Head Position Adjustment] sheet and enter “18.”

Note

- Click the , and  buttons to increment and decrement the current value by one.
- The vertical adjustment range is [-32 to +32] and the horizontal adjustment range is [-30 to +30]; however, each value may not be selected within the overall range depending on the current setting. Select a value between the  mark and the  mark displayed on the slider scale.

10 When the entry is complete, click [Send].

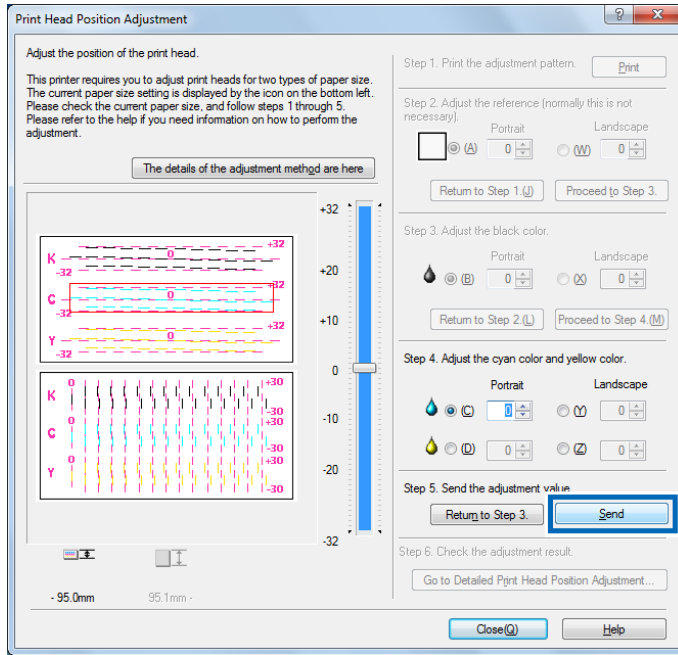

11 When the transmission confirmation window appears, click [Yes].

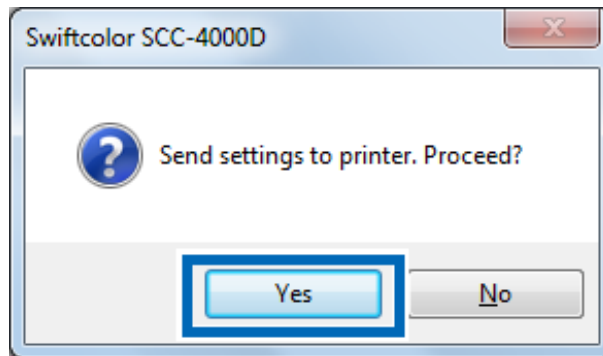

The adjustment value is transmitted to the printer to adjust the head positions.

12

Click [OK].

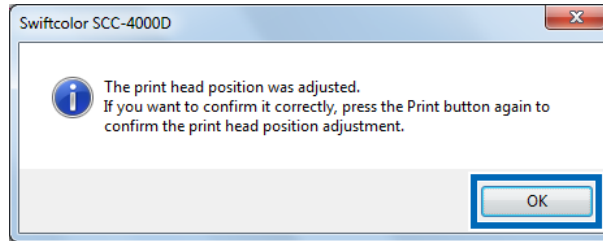

13

Click [Print] again to print a head position adjustment pattern and check that the head positions have been adjusted correctly.

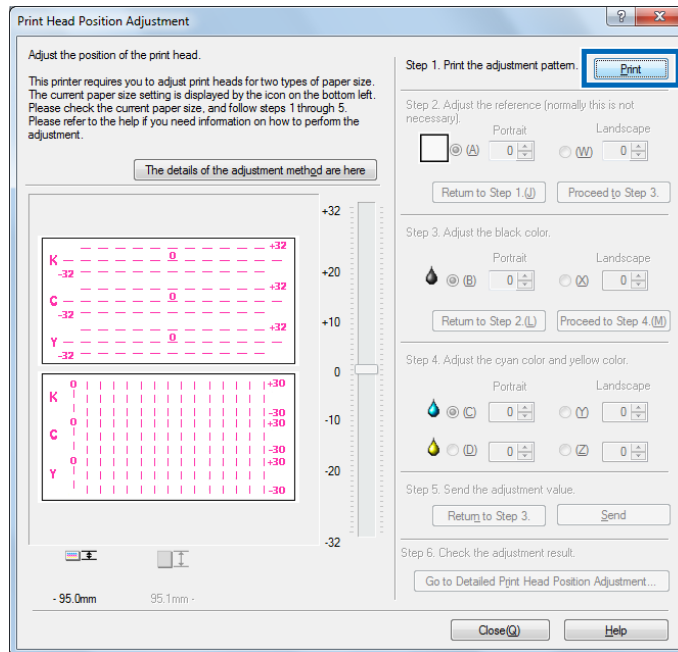

- Check the adjustment pattern printed. If the line at the “0” position in each color appears smoothly linked, go to Step 14.
- If the lines appear out of alignment, retry from Step 1 afterwards.
- To perform finer tuning, click Step 6 [Go to Detailed Printhead Position Adjustment].

➔ 5-1 Cleaning the Printhead (P.135) 5-3 Detailed Printhead Position Adjustment (P.153)

14

When the head position adjustment process is complete, click [Close].

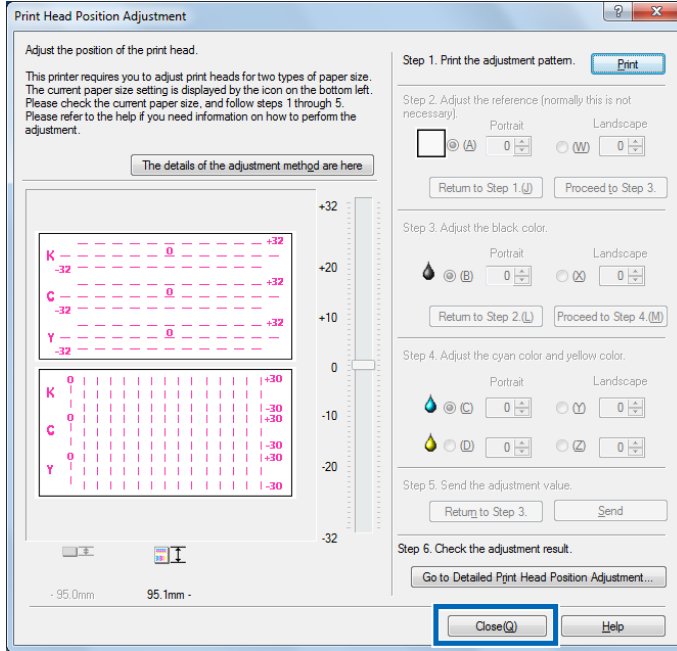

The head position adjustment completion confirmation message is displayed.

15

Click [Yes].

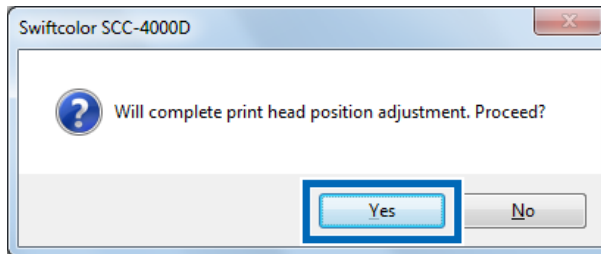

5-3 Detailed Printhead Position Adjustment

These adjustment procedures are intended for maintenance personnel who have completed regular [Printhead Position Adjustment] but seek more detailed adjustment.

Note

- Fine tuning of the printhead cannot be performed for business cards and card-size paper. Apply settings under postcards.

1

Click Step 6 [Go to Detailed Printhead Position Adjustment] without clicking [Close] in Step 13 [Printhead Position Adjustment].

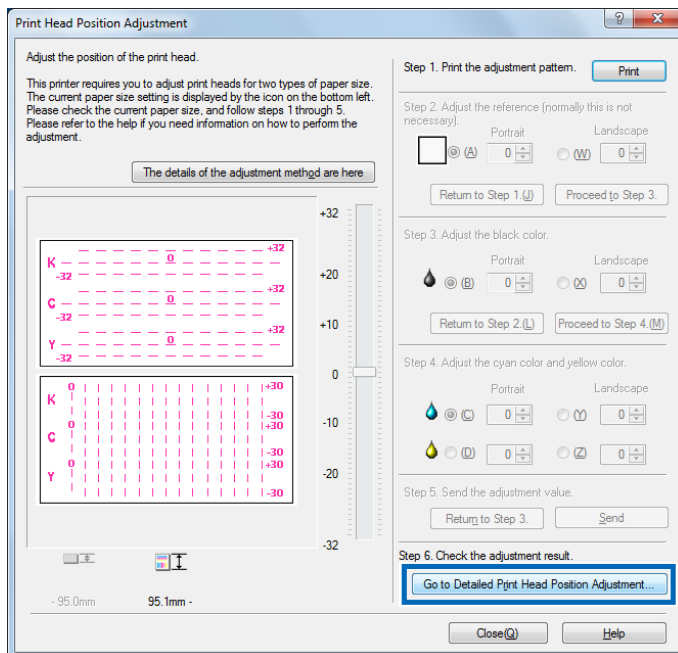

5. Printer Maintenance

The [Detailed Printhead Position Adjustment] dialog box appears.

Click [The details of the adjustment method are here] to view operating procedures from [Help].

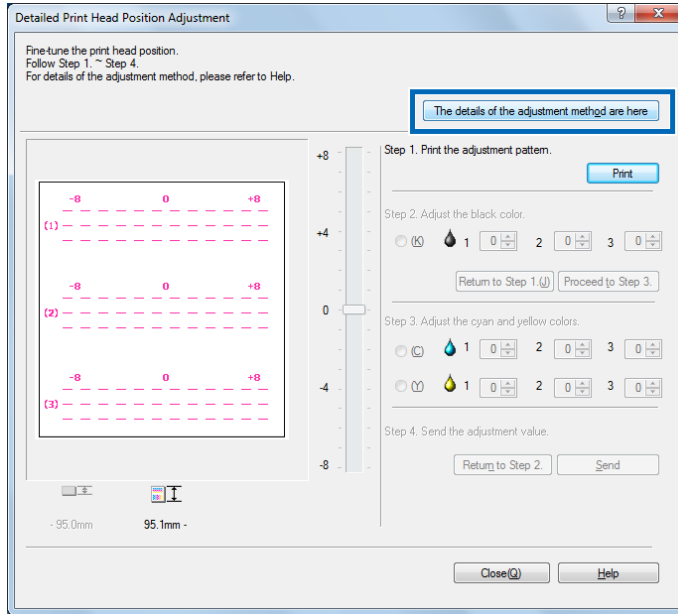

2

Check that the printer is not running, and then click [Print] in Step 1 “Print an Adjustment Pattern.”

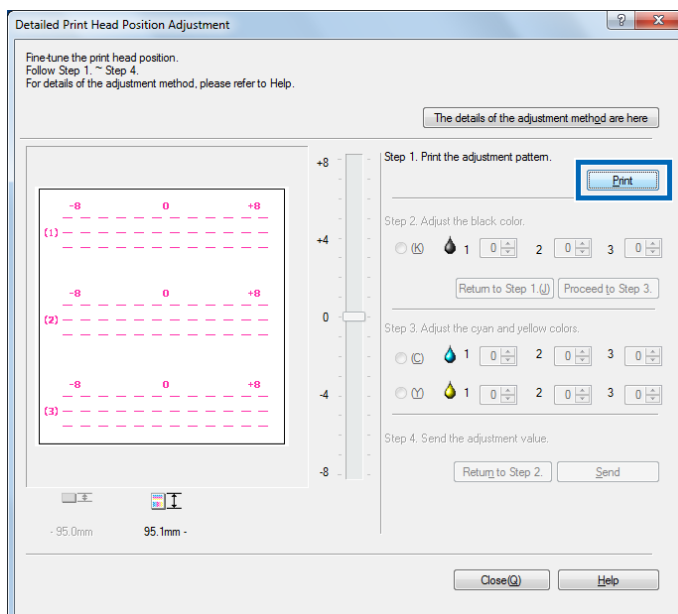

3

When the confirmation window appears, click [Yes].

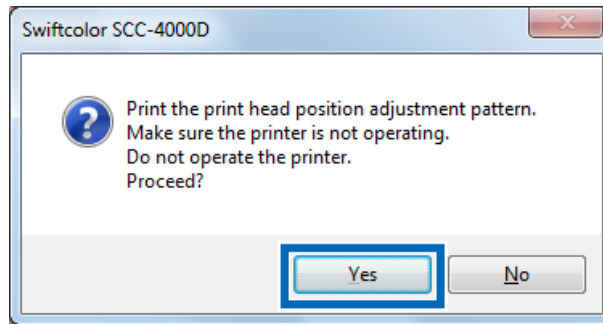
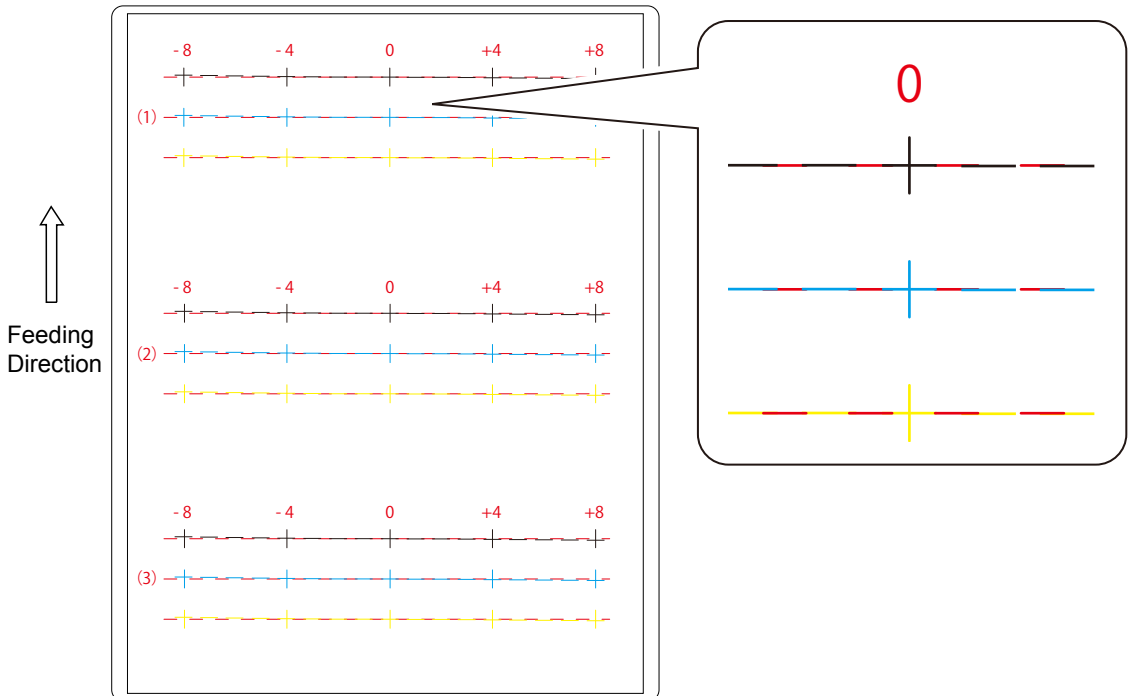
**■ Detailed adjustment pattern**

4

The confirmation window appears to see if the adjustment pattern has been printed correctly or not. Click [Yes].

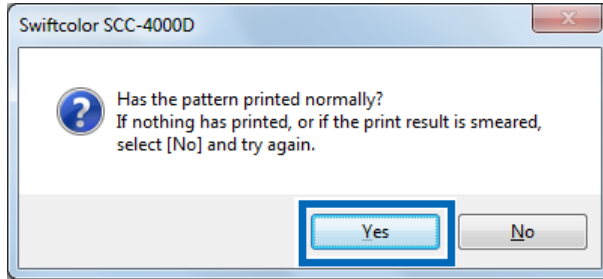

Clicking [No] prints the adjustment pattern again.

5

Step 2. Adjust Black color.

Check [1], [2], and [3] in adjustment pattern [K] (Black) and read and enter the value at the point of their intersection with the Magenta line.

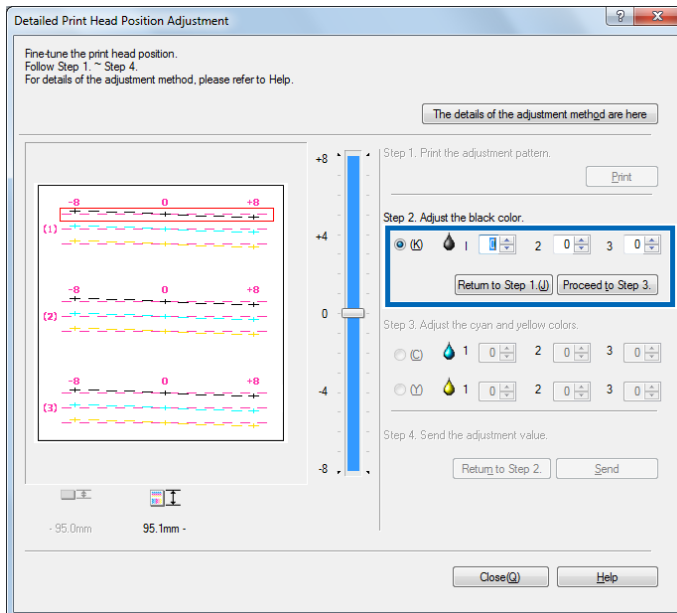

Note

- Selecting [1], [2], and [3] will show the points to view in Red in the adjustment pattern in the [Detailed Printhead Position Adjustment] dialog box.
- To review the last setting entered, click [Return to Step 1].

6

Having entered the adjustment value, click [Proceed to Step 3.]

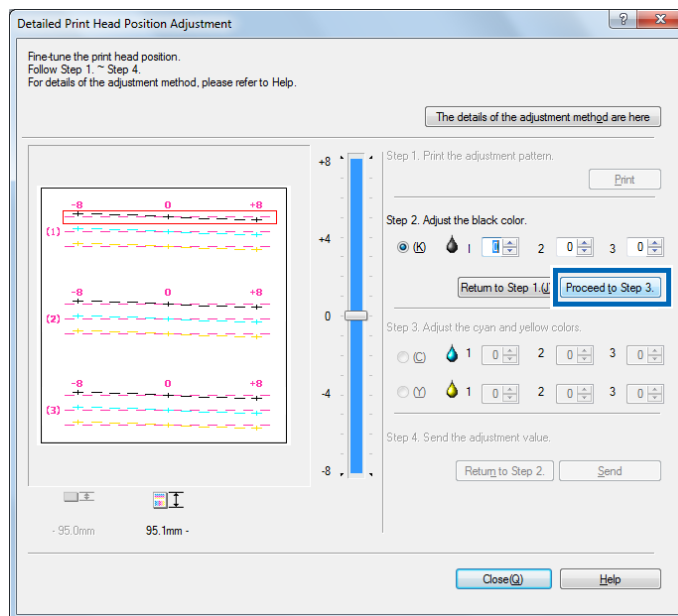

7

Step 3. Adjust Cyan and Yellow.

Check [1], [2] and [3] in adjustment pattern [C] (Cyan) and [1], [2] and [3] in adjustment pattern [Y] (Yellow) and read and enter the value at the point of their intersection with the Magenta line.

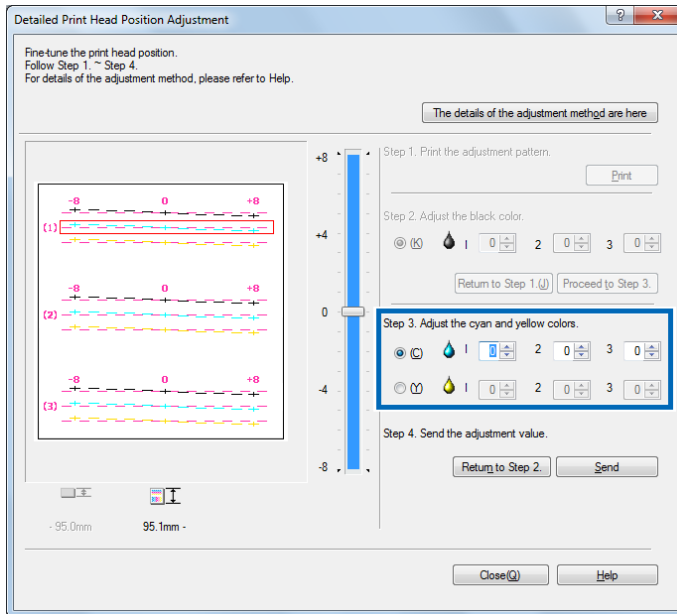

Note

- Selecting [1], [2], and [3] will show the points to view in Red in the adjustment pattern in the [Detailed Printhead Position Adjustment] dialog box.
- To review the last setting entered, click [Return to Step 2].

8

When the entry is complete, click [Send].

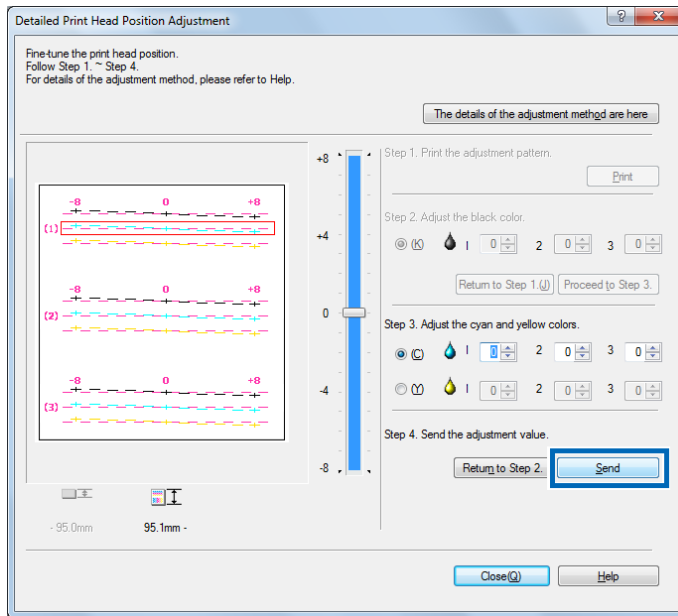

9

The transmission confirmation window appears. Click [Yes].

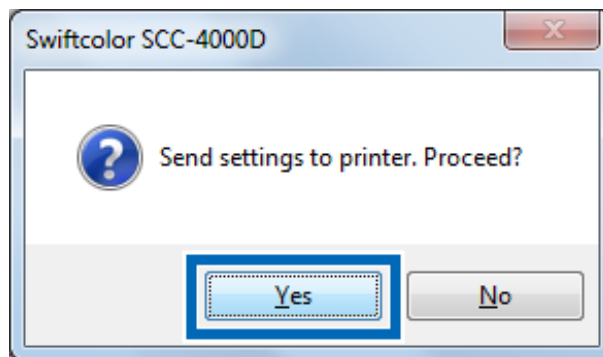

The adjustment value is transmitted to the printer to adjust the head positions.

10 Click [OK].

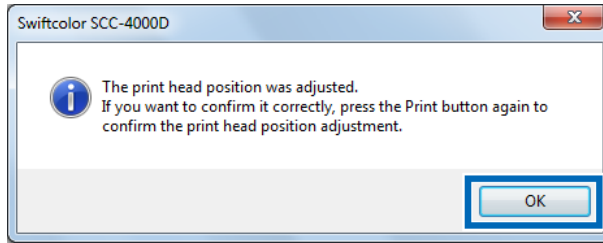

11 Click [Print] again to detailed adjustment pattern and check that the head positions have been adjusted correctly.

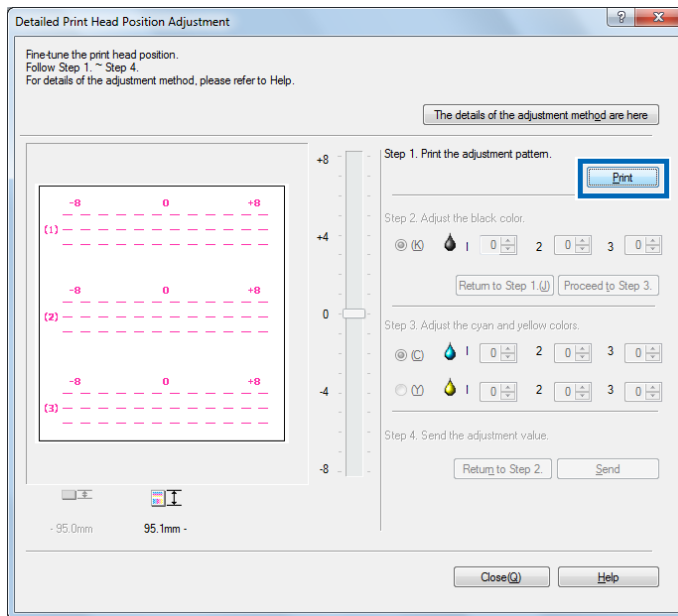

Check the adjustment pattern printed. If the line at the “0” position in each color appears smoothly linked, the adjustment process is completed.

If the lines appear out of alignment, retry from Step 1 afterwards.

12

Click [Close].

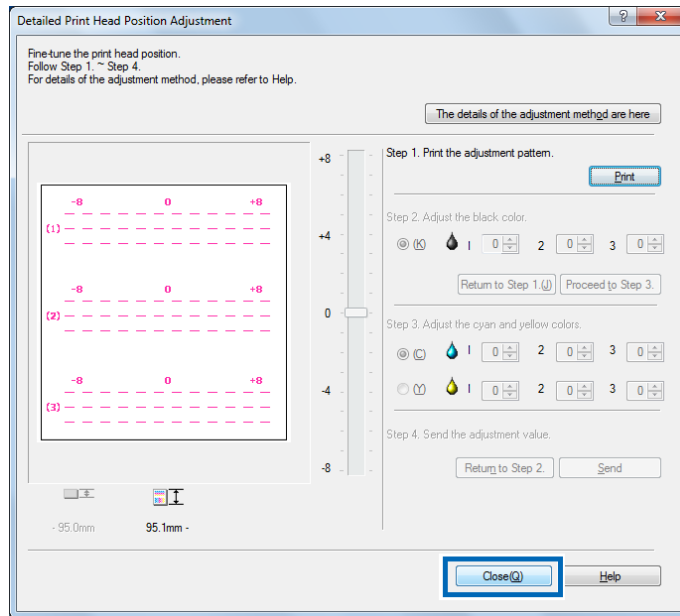

A message is displayed to confirm the completion of the printhead position fine-tuning.

13

Click [Yes].

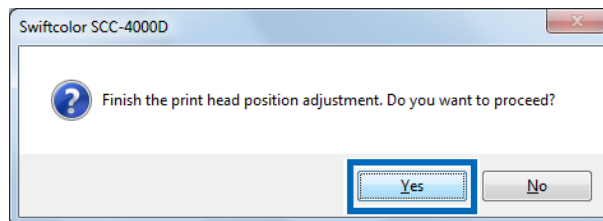

5-4 Check the Output Setting Value

Prints the setting values that are set in the printer. Use dedicated color card printer paper having a paper size of business card (91 mm × 55 mm) or larger to perform ““Output Setting Value.”

Note

- If paper size is smaller than business card (91 mm × 55 mm), the print result may appear void or the setting values not printed on the paper.
- Check that paper has been loaded. When the postcard size or envelope size is selected, the print pattern is printed on three sheets. When the business card size is selected, the print pattern is printed on six sheets.
- Printer settings cannot be printed while printing is in progress or an error persists.

1

Open the [Utility] sheet in the [Swiftcolor SCC-4000D Properties] dialog box and click [Output Setting Value].

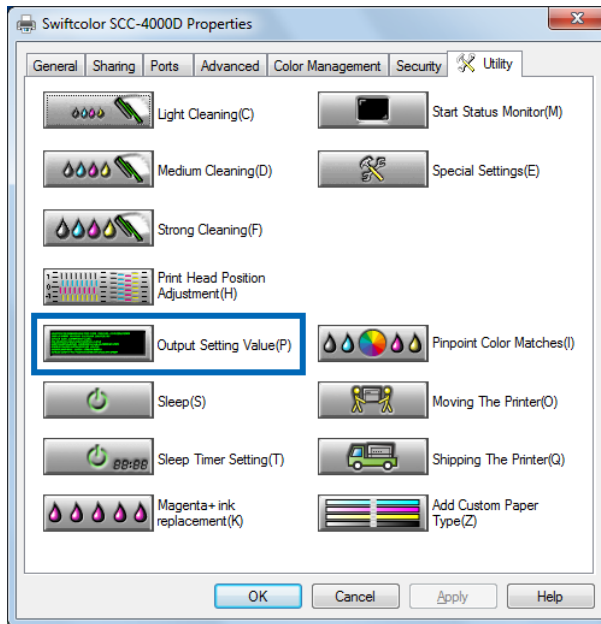

The confirmation dialog box appears.

2

Select [Output to Printer] or [Output to File] and click [Proceed].
Select [Output to Printer] in most situations.

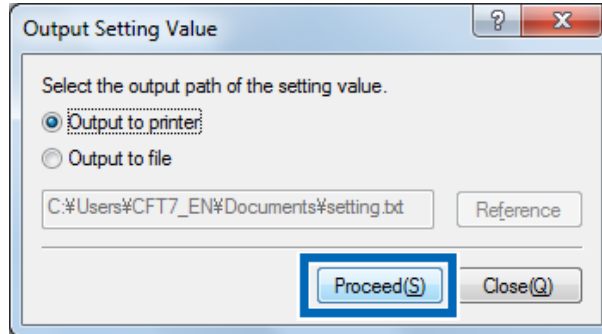

The current setting values set in the printer are printed.

■ How to Read Output Setting Value

```

SCC-4000D
Printer Serial Number ----- No.XXXXX
Firmware ROM Version ----- Ver.00.XX
Date and Time(dd/mm/yyyy) ----- dd/XXX/20XX XX:XX dot
Printhead Position Adjustment-V(Long Paper)
    K----- X dot
    C----- X dot
    M----- X dot
    Y----- X dot
Printhead Position Adjustment-H(Long Paper)
    K----- X dot
    C----- X dot
    M----- X dot
    Y----- X dot
Printhead Position Adjustment-V(Short Paper)
    K----- X dot
    C----- X dot
    M----- X dot
    Y----- X dot
Printhead Position Adjustment-H(Short Paper)
    K----- X dot
    C----- X dot
    M----- X dot
    Y----- X dot

Ink Pre-fire on the paper ----- XXX
Paper Stain Reduction Mode ----
Sleep Timer Setting ----- XXX min
Power Off Timer Setting ----- XXX min
Ethernet Information
    Use DHCP ----- XXX
    Mac Address ----- XX-XX-XX-XX-XX-XX
    IP Address ----- XXX.XXX.XXX.XXX
    Subnet Mask ----- XXX.XXX.XXX.XXX
    Default Gateway ----- XXX.XXX.XXX.XXX

```

*When [Output to File] is selected, setting values are saved in a text format.

5-5 Replacing Ink Tanks

When the remaining ink level becomes low, the message “XXXX ink low” is displayed on the Status Monitor to notify you that the corresponding ink tank will soon be out of ink. When the ink tank has become out of ink although printing can be continued, the message “Out of XXXX ink” is displayed and printing stops.

The printer has tanks of four colors: black (Bk), cyan (C), magenta (M), and yellow (Y).

Confirm the message displayed on the Status monitor and replace the ink tank which has become out of ink.

Caution

- For safety, keep the ink tank out of the reach of children.
- If ink is accidentally ingested, contact a physician immediately.

Important

- To maintain printhead quality, printer stops operating before it is completely out of ink. Therefore, a small amount of ink remains in ink tank to be replaced.
- To get a good printing result, use up each ink tank within six months of the first opening the package.
- Do not remove an ink tank unless you must replace it. This could shorten the life of the consumables.
- Complete the ink tank replacement procedure as quickly as possible. Do not leave the printer with ink tanks removed.
- An ink tank left in a high-temperature place can deform. However, there is nothing wrong with its functions.
- It is recommended that ink tanks be stored in a place where the temperature does not rise extremely.

Note

- When the message “XXXX ink low” is displayed, get a new ink tank as soon as possible. For how to get a new ink tank, contact your local dealer.
- To maintain the best printing quality, please use only Swiftcolor SCC-4000D ink tanks. When purchasing ink tanks, check that they bear the following model numbers:

Black Ink Tank: SCC-D400BK

Cyan Ink Tank : SCC-D400C

Magenta Ink Tank: SCC-D400M+

Yellow Ink Tank: SCC-D400Y

- The positions of the ink tanks are as shown below.

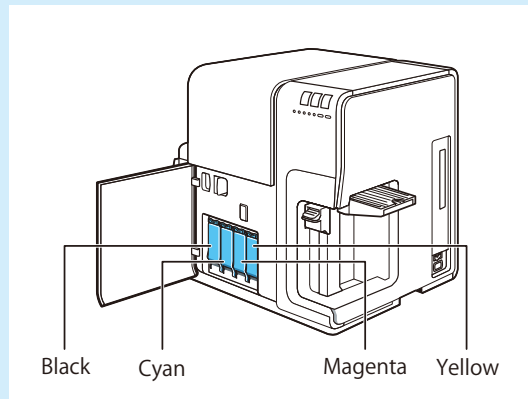

The printer is designed so that ink tanks cannot be inserted in wrong ink tank slots. Do not attempt to insert ink tanks in wrong ink tank slots forcibly.

- 1** Open the ink tank door.

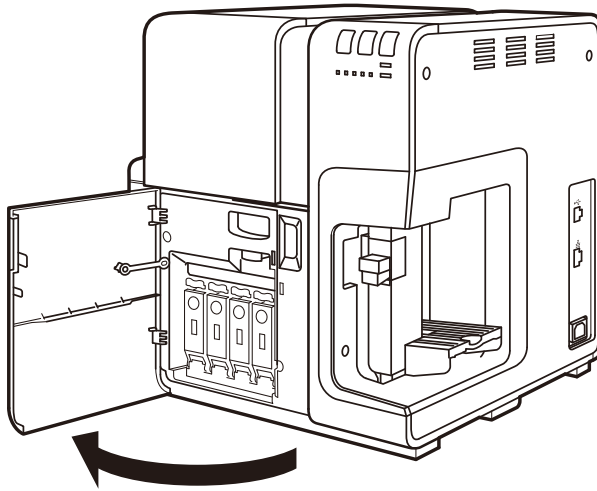

- 2** Open the ink tank cover.

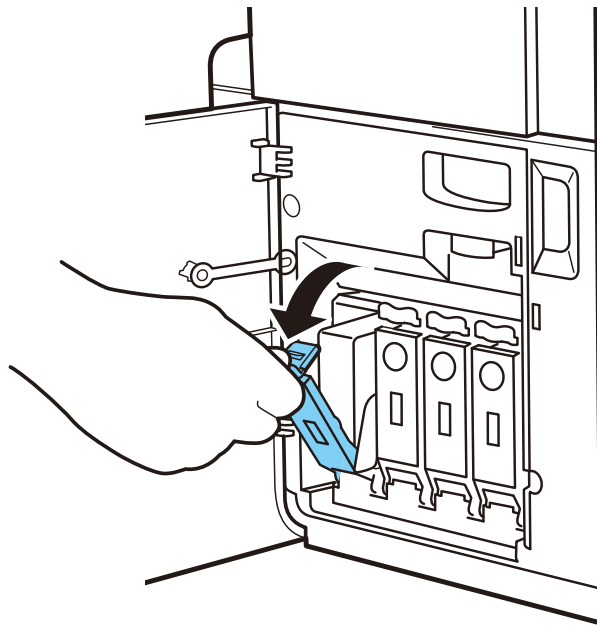

3

Pull out an empty ink tank slowly.

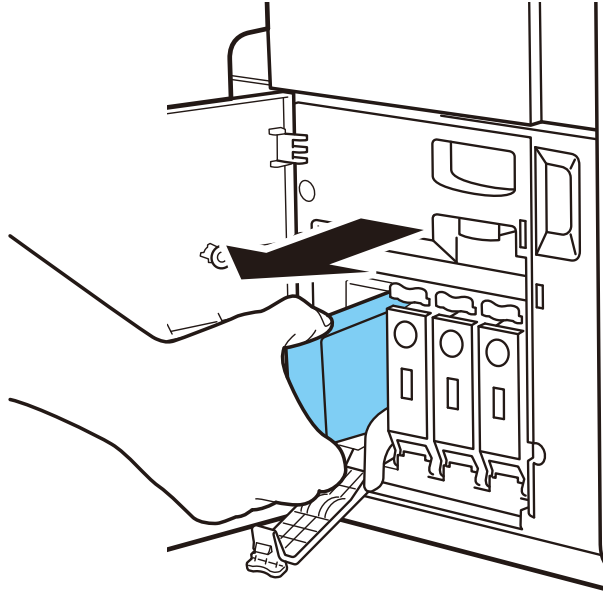

4

Take out a new ink tank from the box.

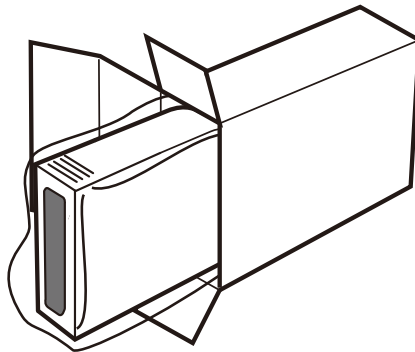

Important

- Do not touch the ink outlet and terminal to prevent soiling of the the surrounding work area, damage to the ink tank, and poor printing.

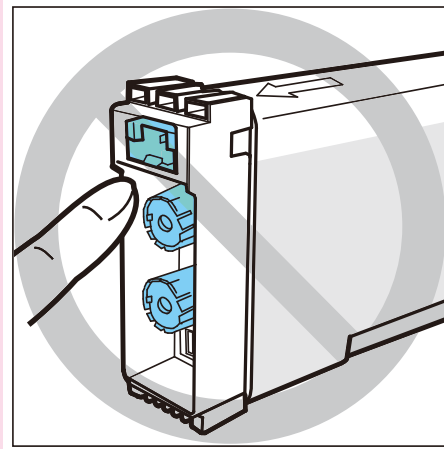

- Never apply excessive force nor drop an ink tank. Ink can stain clothing and the work area.

5

Load a new ink tank.

Slowly insert the ink tank deeply into the ink tank slot with the correct side up.

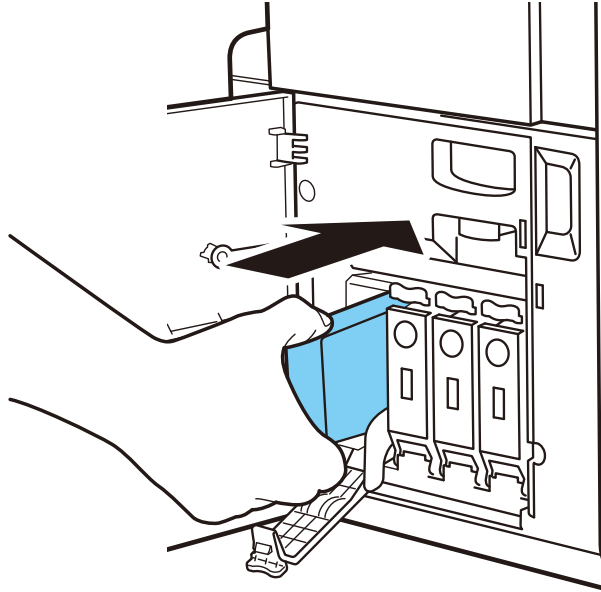

Caution

- There are sharp pins in ink tank slots. Never put your fingers into this area.

6

Close the ink tank cover securely.

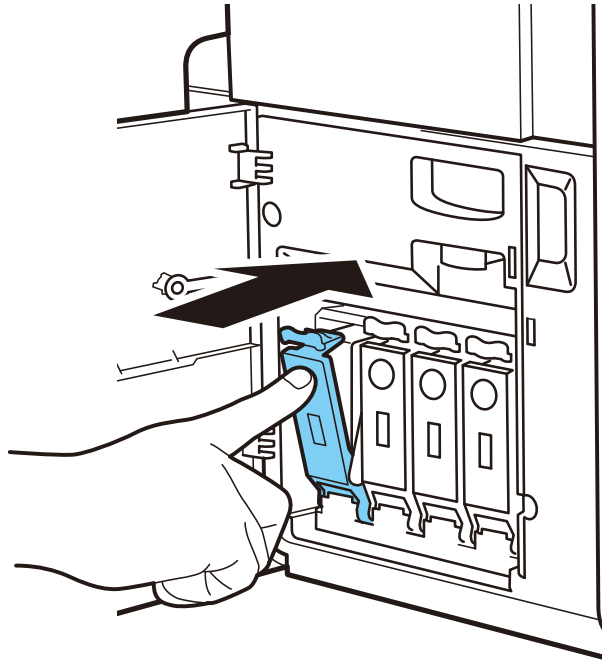

7

Close the ink tank door.

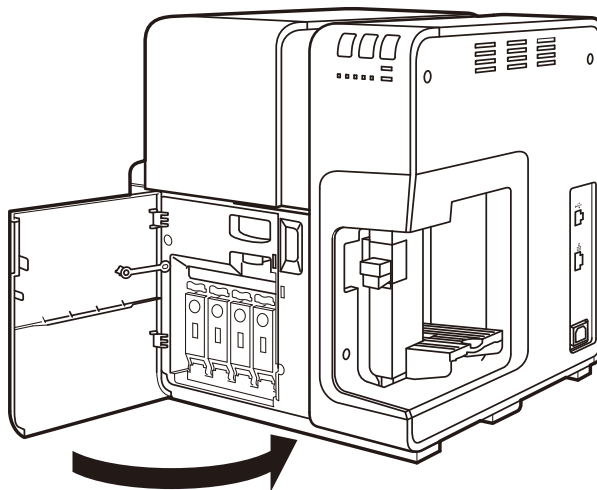

5-6 Replacing the Maintenance Cartridge

When the maintenance cartridge is filled with the collected ink, the message “Maintenance cartridge full error” is displayed in the status information area on the Status Monitor, and the printer stops.

Get a new maintenance cartridge, and replace it with the old one.

Caution

- For safety, keep the Maintenance Cartridge out of the reach of children.
- If ink is accidentally ingested, contact a physician immediately.

Important

- To prevent ink from leaking from a used Maintenance Cartridge, avoid dropping the cartridge or storing it at an angle. Otherwise, ink may leak and cause stains.
- Ink adheres to the top of the Maintenance Cartridge after it has been used. Handle the Maintenance Cartridge carefully during replacement. The ink may stain clothing.

Note

- When purchasing maintenance cartridges, check that they bear the following model number:
Maintenance cartridge : Model name : MC-01

1

When the maintenance cartridge is filled with collected ink, an error message is displayed on the Status Monitor.

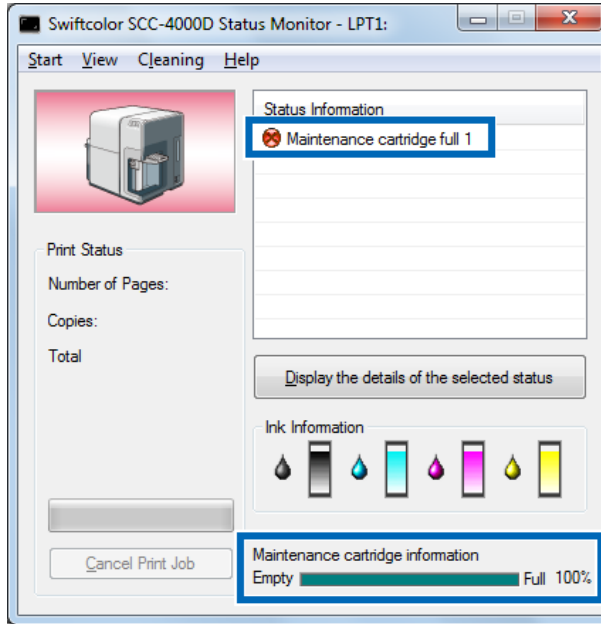

2

Open the maintenance cartridge door.

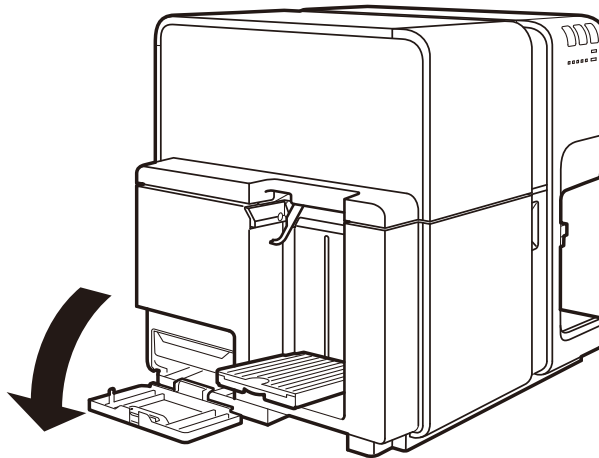

3 Draw out the maintenance cartridge slowly.

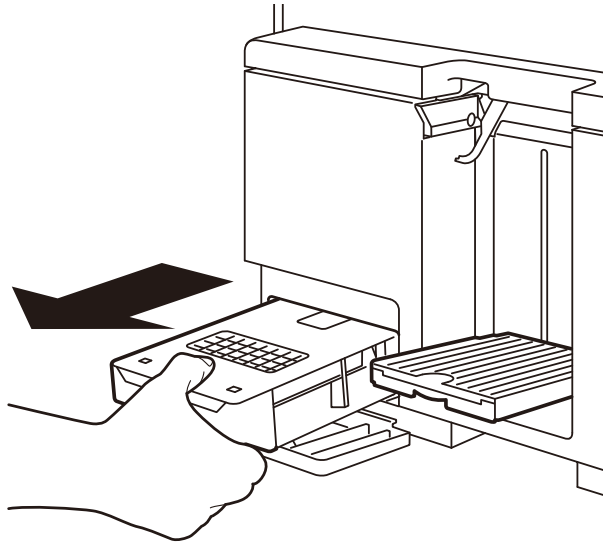

Important

- When removing the maintenance cartridge full of ink, take care not to incline or drop it. The spilled or scattered ink may stain the floor or clothing.

4 Take out a new maintenance cartridge from the box.

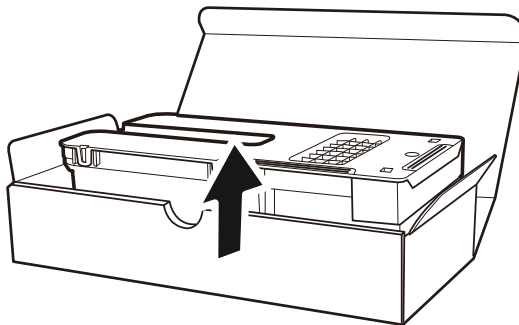

5 Insert a new maintenance cartridge.

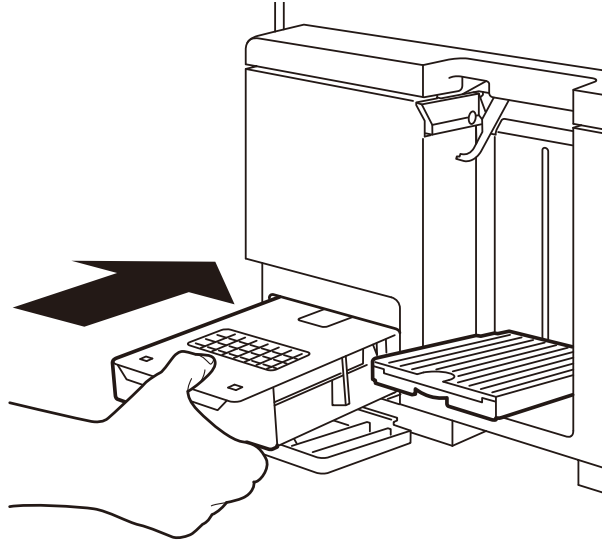

6 Close the maintenance cartridge door.

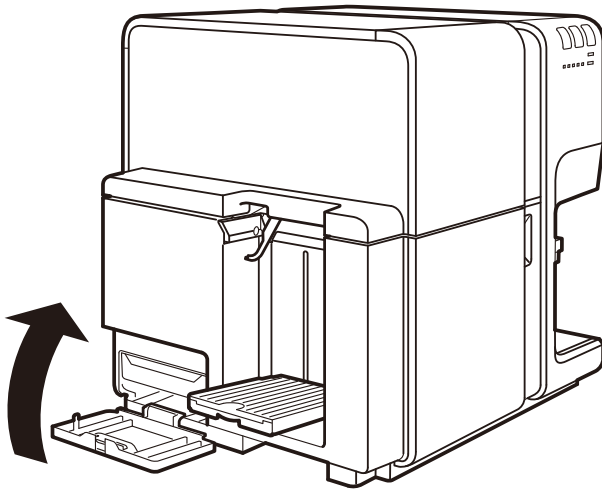

The error message on the Status Monitor disappears, and printing starts.

7

Put the used maintenance cartridge in the plastic bag included with the new maintenance cartridge and properly dispose it.

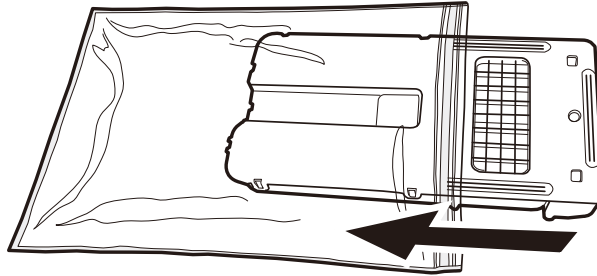

5-7 Used Ink Tanks

Important

- Dispose the used ink tank in accordance with local laws and regulations.

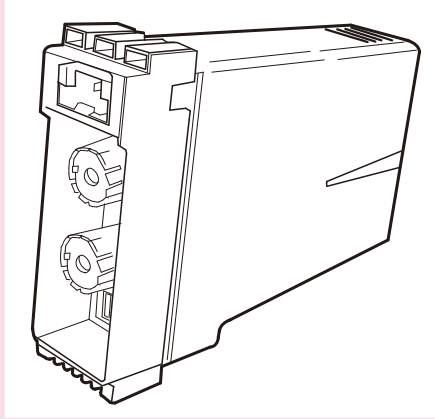

5-8 Used Maintenance Cartridge

Important

- Dispose the used maintenance cartridge in accordance with local laws and regulations.

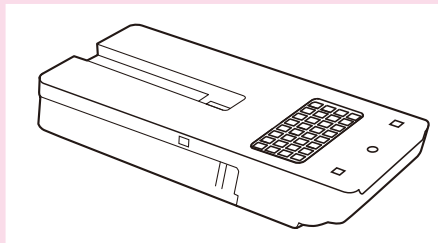

5-9 Cleaning the Printer

As the printer is used, ink and paper dust will be collected inside the printer. If the interior of the printer becomes dirty, this will cause prints to become dirty or interfere with smooth paper feeding. Clean the printer periodically to keep the printer in optimum working condition.

Dampen a clean cloth in a weak solution of water and detergent, wring it out thoroughly, then use it to clean the exterior covers of the printer.

Warning

- **When cleaning the outside and inside of the printer, do not use a flammable solvent such as thinner, benzene, or alcohol. A fire or electric shock may result.**

Caution

- **Be sure to remove the power plug from the outlet before cleaning the printer. This can prevent personal injury or damage to the printer if you make a mistake during cleaning.**

1

Press the power key for at least 1 second to put the printer in the power-off state. Remove the power plug from the outlet.

- 2** Open the ink tank door.

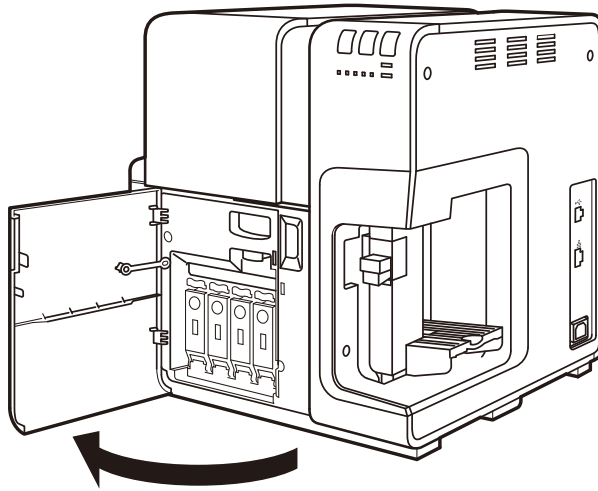

- 3** Press the upper unit release lever to open the upper unit.

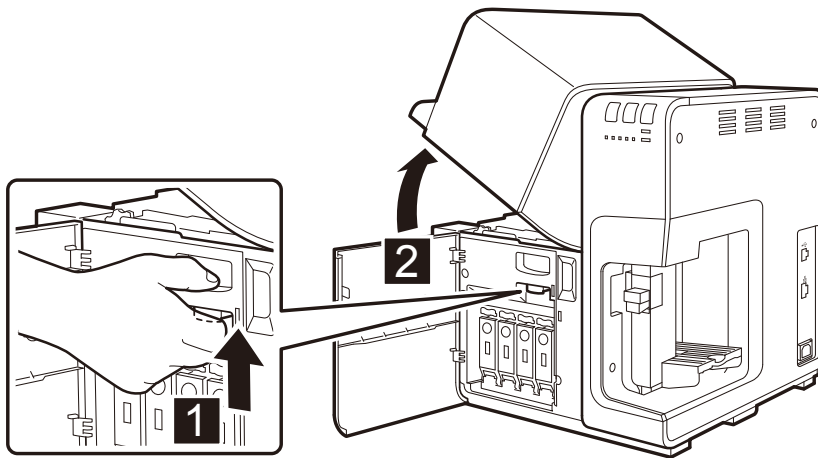

4

Using a dry cloth, thoroughly remove ink, dust, and paper dust around the transport area.

**Note**

- Do not use paper towels or tissue paper. Cut paper chips or paper dust entering the printer may cause failures.
- When cleaning the transport belt, turn the jam recovery dial in the paper feed direction.

5

After completion of cleaning, close the upper unit, then close the ink tank door.

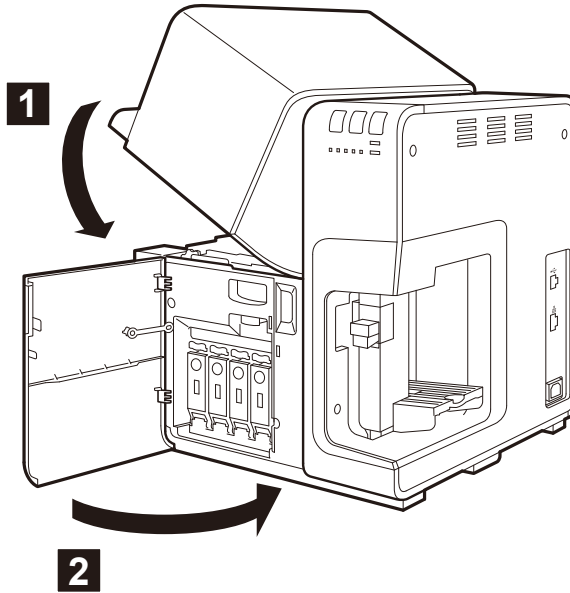

6. Troubleshooting

This section describes how to troubleshoot problems when the printer is not operating correctly.

If you cannot solve the problem by following these troubleshooting procedures, please contact the dealer where you purchased the printer or the nearest contact your dealer.

6-1 Error or Warning Messages

The Status Monitor will display a warning or error message when a problem occurs in the printer while it is idle or during a print job.

Note

- When an error message is displayed, the printer automatically enters the offline mode. Even after recovery of the error, the printer may not enter the online mode automatically depending on the type of the error. In this case, press the power key to place the printer to the online mode forcibly.
- If multiple errors occur simultaneously, all the relevant messages will appear in the Status Monitor. Take remedial actions to revolve the individual errors.

■ Operator Call Error Messages

Error Message	Problem	Solution
Upper unit open.	The upper unit is open.	Close the upper unit.
Ink tank door open.	The ink tank door is open.	Close the ink tank door.
Maintenance cartridge door open.	The maintenance cartridge door is open.	Close the maintenance cartridge door.
Pinch roller cover open.	The pinch roller cover is open.	Close the pinch roller cover.
Paper empty 1.	Paper has run out.	Load paper. → 1-4 Paper Loading Procedure (P.16)

6. Troubleshooting

Error Message	Problem	Solution
Paper Length different 1 to 3.	The print data and the length of the paper loaded do not match.	Check the print data and the length of the paper loaded.
Paper Width different.	The width of the paper loaded differs from the paper size setting of the application software and the printer driver.	<p>If wrong paper is loaded or the side guide is displaced, replace with correct paper or move the side guide to the correct position.</p> <p>→ 1-4 Paper Loading Procedure (P.16)</p> <p>If the application software and the printer driver have been configured incorrectly, click [Cancel Print Job] in the Status Monitor.</p> <p>Set the correct paper size and then retry the print job.</p>
Paper jam 1 to 26.	The transport path, feeder, or delivery area is clogged with paper.	<p>Reload the paper. If the problem recurs, contact the dealer from whom this printer was purchased or our contact your dealer.</p> <p>→ 1-4 Paper Loading Procedure (P.16)</p> <p>→ 6-2 When Paper is Jammed (P.186)</p>
Feeder tray overloaded	The amount of paper loaded in the feeder tray is over the limit.	<p>Load paper so that the number of sheets is less than the specified amount and the top surface of the paper stack is lower than the paper loading limit mark.</p> <p>→ 1-4 Paper Loading Procedure (P.16)</p>
Stacker overloaded	Paper ejected to the auto stacker has exceeded the upper limit.	Remove the ejected paper.
Stacker inspection	Long paper such as an envelope or postcard is stationary in the transport area or paper eject slot.	<p>Remove the jammed paper.</p> <p>→ 6-2 When Paper is Jammed (P.186)</p>
Paper retention 1 to 4	Paper still remains after removal of jammed paper.	<p>Open the upper unit and check the Transport area.</p> <p>→ 6-2 When Paper is Jammed (P.186)</p>

Error Message	Problem	Solution
Feed error 1	The paper is not fed.	Reload the paper and try again. → 1-4 Paper Loading Procedure (P.16)
Feed error 2	Paper has been pulled out of the feeder tray during printing.	Do not pull out paper during printing. If it is absolutely necessary to pull out paper during printing, press the PAUSE key on the operation panel to stop printing temporarily, and then pull out paper.
Thick feed lever position error 1	The thick paper transport lever is not pulled.	Pull the thick paper transport lever. → To those who use thick paper (P.23)
Thick feed lever position error 2	The thick paper transport lever is held at the upper position.	Push in the thick paper transport lever. → To those who use thick paper (P.23)
XXXX ink empty.	The XXXX ink has run out.	Replace with a new ink tank. (XXXX represents Black, Cyan, Magenta, or Yellow.)
XXXX ink tank setting error.	The ink tank is not installed correctly.	Install the ink tank again. (XXXX represents Black, Cyan, Magenta, or Yellow.)
XXXX ink tank abnormality 1 to 5.	The ink tank is abnormal.	Replace with a new ink tank. (XXXX represents Black, Cyan, Magenta, or Yellow.)
Maintenance cartridge full.	The maintenance cartridge is full with collected waste ink.	Replace with a new maintenance cartridge. → 5-6 Replacing the Maintenance Cartridge (P.171)
Maintenance cartridge setting error.	The maintenance cartridge is not installed correctly.	Install a maintenance cartridge again.
Maintenance cartridge abnormality 1 to 4.	The maintenance cartridge is abnormal.	Replace with a new maintenance cartridge. → 5-6 Replacing the Maintenance Cartridge (P.171)
Update error 1 to 4.	The firmware update has failed.	Retry the update. If the same operator call recurs after taken remedial actions to it, contact the dealer from whom this printer was purchased or our contact your dealer.

6. Troubleshooting

Error Message	Problem	Solution
Data mismatch 1.	Invalid data has been received from the host.	Check the cable connection and retry.
Data mismatch 2.		Check the cable connection and retry.
Data mismatch 3.		Check the form file information and retry.
Data mismatch 4.		Check the paper shape setting of the printer driver before rerunning the print job.
Memory full.	Memory is lack of capacity because the size of form data for overlay printing is too large.	Cancel printing and create the Form Data again. → 3-5-1. Create Form (P.81)
Overlay data error.	Form overlay data is invalid.	Check the cable connection and retry.
XXXX ink level unknown.	The remaining ink cannot be detected.	Replace with a new XXXX ink tank. Continued printing could cause damages to the printer. To continue printing, press the printer [PAUSE] key for 5 seconds or longer. In this case, the remaining ink sensor function is disabled, and the state of the function having been disabled is logged. (XXXX represents Black, Cyan, Magenta, or Yellow.) → About the remaining ink level detection function (P.197)
Unknown error.	An unknown operator call has occurred.	Contact the dealer from whom this printer was purchased or our contact your dealer.
Connected to a model other than Swiftcolor SCC-4000D.	Connected to a printer other than the Swiftcolor SCC-4000D.	Connect to the Swiftcolor SCC-4000D.
Unable to communicate with the printer bidirectionally.	The computer and the printer cannot use bi-directionally communication.	Check the printer power and make sure that the printer is in the online or sleep mode, or restart the computer and printer.

■ Warning Messages

Error Message	Problem	Solution
XXXX ink low.	The Bk/C/M/Y inks are diminishing.	Prepare new ink tanks. (XXXX represents Black, Cyan, Magenta, or Yellow.)
Maintenance cartridge level low.	The maintenance cartridge will be full with collected waste ink soon.	Replace with a new maintenance cartridge.
Change XXXX printhead.	Time to replace the Bk/C/M/Y Printheads.	Note the message and contact the dealer from whom this printer was purchased or our contact your dealer. (XXXX represents Black, Cyan, Magenta, or Yellow.)
Change purge unit.	The purge unit has passed the time for replacement.	Note the message and contact the dealer from whom this printer was purchased or our contact your dealer. (XXXX represents Black, Cyan, Magenta, or Yellow.)
Change Blade Cleaner.	The blade cleaner has passed the time for replacement.	Note the message and contact the dealer from whom this printer was purchased or our contact your dealer. (XXXX represents Black, Cyan, Magenta, or Yellow.)
Change transport unit.	Time has come to replace the transport unit.	Note the message and contact the dealer from whom this printer was purchased or our contact your dealer. (XXXX represents Black, Cyan, Magenta, or Yellow.)
Stopping XXXX ink level detection.	The remaining XXXX ink level sensor function is disabled.	Install a new ink tank to return to normal. (XXXX represents Black, Cyan, Magenta, or Yellow.)
Unknown warning.	An unknown warning has been received.	Check the printer driver version.

■ Fatal Error

Error Message	Problem	Solution
Service call error (#****)	An irrecoverable error has occurred.	Turn the power off, then back on. If the same error recurs, note the message and contact the dealer from whom this printer was purchased or our contact your dealer.

6-2 When Paper is Jammed

If a paper jam occurs during printing, printing is suspended and the error message “Paper jam X” is displayed.

Remove the jammed paper following the procedure described below.

- 1 Open the ink tank door.

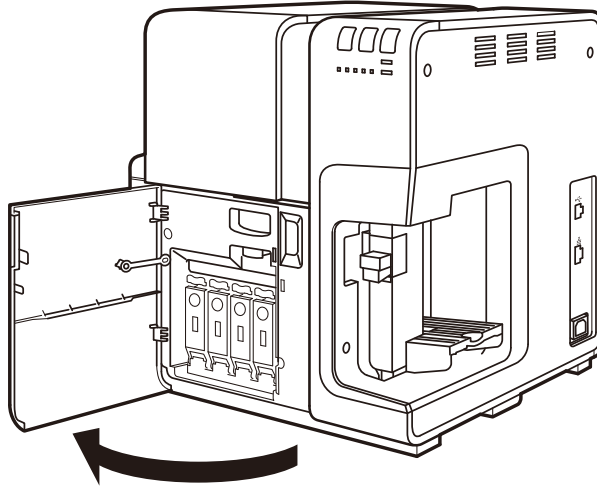

- 2 Press the upper unit open lever to open the upper unit.

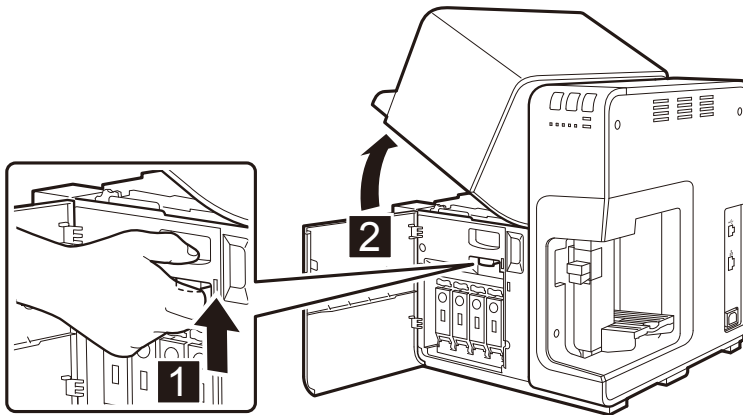

3

While turning the jam recovery dial in the direction to eject paper, remove jammed paper from the transport section.

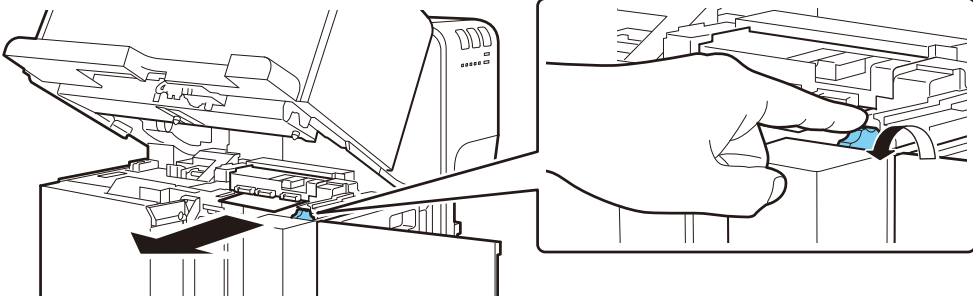
**4**

If paper cannot be removed in step 3, remove it by turning the dial in the direction to eject paper with pinch roller opened.

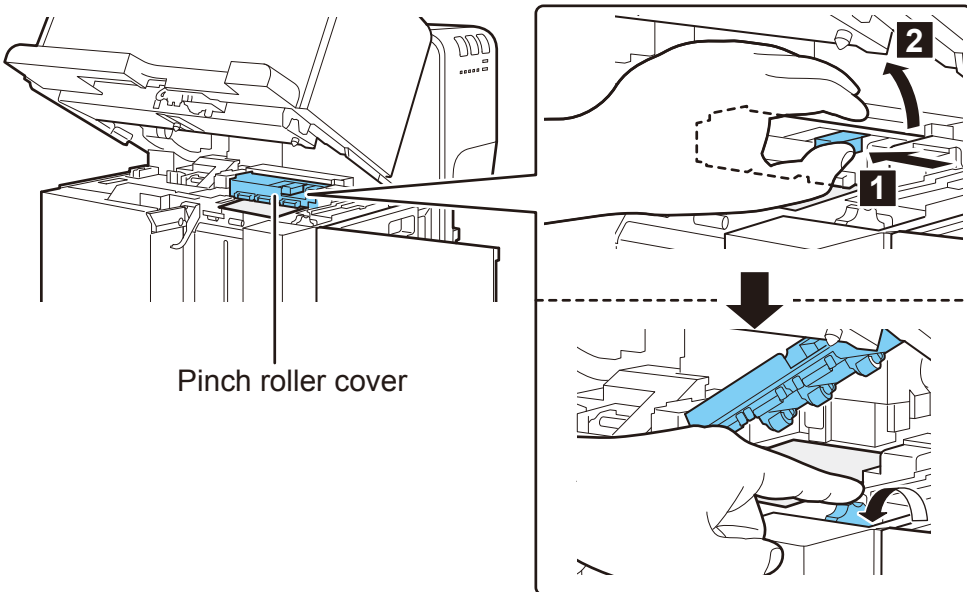

5

After removing paper, return the pinch rollers to their original positions, close the upper unit, and then close the ink tank door.

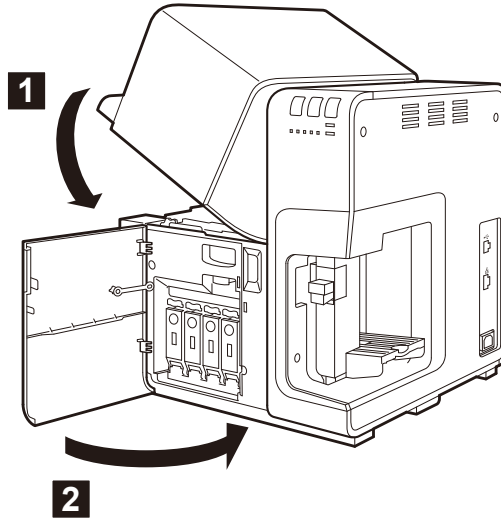

6

Set paper again.

→ 1-4 Paper Loading Procedure (P.16)

7

Printing restarts.

Note

- To cancel the print job, click [Cancel Print] in the Status Monitor.
→ 2-2 Canceling Print Jobs (P.34)

6-3 Printer Not Operating Correctly

Check the following points if the printer is not operating correctly.

■ Power off

Check Point	Solution
Power key is at the off.	Press power key.
Printer power cord unplugged.	Make sure that the power cord is plugged in completely.
Power supply not providing power.	Connect another device to the power supply to confirm that the outlet is providing power. If you cannot restore the printer to normal operation, call the dealer or contact the nearest contact your dealer.

■ Printer Does Not Start or Printer Stops During Print Jobs

Check Point	Solution
Upper unit or ink tank door or maintenance cartridge door is open. (Please confirm a status monitor.)	Close the upper unit or ink tank door or maintenance cartridge door and make sure that it is closed tightly.
Printer is not connected to the computer.	Check a cable and make sure that it is connected to the printer and the computer.
Paper is not loaded correctly.	Load paper correctly. → 1-4 Paper Loading Procedure (P.16)
The ink tanks are not installed correctly.	Check the ink tanks and make sure that the are installed correctly. → 5-5 Replacing Ink Tanks (P.164)
The Swiftcolor SCC-4000D printer driver is not selected on the computer.	Make sure that the Swiftcolor SCC-4000D Printer is selected when you start the print job.
Print data contains an image with a large capacity.	If you see the STATUS lamp flashing, this means that data is processing. Wait for the processing to finish.

6. Troubleshooting

Check Point	Solution
The printer has been printing for a long period.	If the printer prints for a long period the printhead may overheat. To protect the printhead the Status Monitor will display a printhead overheated messages and stop the print job. Just wait for the printhead to cool down.
The print destination port setting is wrong.	Open the printer driver Properties and make sure that the port setting is correct. If the port setting is not correct, shut down Windows, switch off the computer, then reconnect to the selected port. Follow the procedure below to check the port setting. Open the printer driver Properties window then click the Ports tab. If you are using a USB connection, make sure that USB nnn (nnn represents the numbers) is selected for the port setting.
Check whether a test pattern is printed.	Try printing a Printhead Position Adjustment pattern or output setting values by selecting the corresponding button on the [Utility] sheet of the printer driver. If the test pattern is printed, check the application software settings, operation method, and print data content. If the test pattern is not printed, contact your dealer.
The problem is occurring on the computer.	Shut down the computer and switch it on again then try to print. Be sure to cancel the print job if it remains after the computer is restarted.
Check whether an option other than “None” is selected for the system standby setting or sleep mode setting of Windows running on the computer.	When printing data, select “None” for the system standby setting or the setting of the time before entering the sleep mode of Windows running on the computer. Note that data sent from the computer is discarded when the computer is recovered from the standby mode. To configure the system standby setting or sleep mode setting, click the [Start] button of Windows, select [Control Panel] from the [Start] menu, and then select [Power Options].

Check Point	Solution
Check if the ink Tank has ink left but still displays [Run Out of Ink].	Detach the ink Tank and attach it again. If the problem persists, contact your dealer.

**■ Printing Does Not Stop/ Data is Not Sent/ Settings are Not Sent from Utility/
Status Cannot be Recognized on the Status Monitor.**

Check Point	Solution
Check whether Print Queue window (in which print data order is registered) remains.	<p>Stop the printer temporarily to cancel printing from the Status Monitor, or delete the Print Queue window data. Next, reboot the computer.</p> <p>If you carry out setting related to printing and utility when the printer is connected to the network, a data transfer error occurs between the computer and the printer due to antivirus software. As a result, Print Queue window data may be sent to the printer multiple times or not be sent to the printer.</p> <p>If this symptom occurs, contact your dealer.</p>

■ Paper is Not Feeding Correctly

Check Point	Solution
Check whether non-exclusive paper is used.	Use paper exclusively for the color card printer. Using non-exclusive paper can result in a paper jam or failure. → 3-2-6.Paper Type (P.61)
The edge of the paper is folded or curled.	If the leading edge of the paper is folded or curled it will not feed correctly. This could also cause a paper jam.
Check whether the side guide is set in accordance with the paper width.	Set the side guide in accordance with the paper width. → 1-4 Paper Loading Procedure (P.16)
The transport area is dirty.	A transport area smeared with paper dust or ink would be more prone to a paper jam or any other trouble. Clean the transport area if it is found dirty. → 5-9 Cleaning the Printer (P.177)

■ Status Monitor Does Not Start

Check Point	Solution
The Status Monitor setting is incorrect.	With some Status Monitor settings, printer errors will not be displayed and the Status Monitor will not start. Open the printer driver Utility sheet then click Start Status Monitor. Set the details after the Status Monitor starts. → 4-1 Displaying the Status Monitor (P.119)
Check whether the printer and computer can communicate interactively.	If the printer and computer cannot communicate interactively, the Status Monitor does not start even if printing starts. Open [Properties] of the printer driver, click the [Port] tab, and then check that the [Enable bidirectional support] check box is checked. If the problem persists after taking the above action, uninstall the printer driver, and then reinstall the printer driver.

6-4 Print Results Are Unsatisfactory

If the print results are not what you expect, confirm the following points.

■ Back of Paper Stained

Check Point	Solution
Check whether the paper transport section is stained with ink.	Clean the Transport area. → 5-9 Cleaning the Printer (P.177)

■ Random, Bizarre Characters Are Printed

Check Point	Solution
A Interface cable is disconnected.	Check a Interface cable and make sure that it is connected to the printer and the computer.
The Swiftcolor SCC-4000D printer driver is not selected on the computer.	Make sure that the Swiftcolor SCC-4000D Printer is selected when you start the print job.
Check whether a test pattern is printed.	Try printing a Printhead Position Adjustment pattern or output setting values by selecting the corresponding button on the [Utility] sheet of the printer driver. If the test pattern is printed, check the application software settings, operation method, and print data content. If the test pattern is not printed, contact your dealer.

■ Slow To Print

Check Point	Solution
Check whether the number of copies is specified on the application side.	If the number of copies is specified on the application side, new print data is sent each time printing of a copy is completed, requiring a long time to finish printing the specified number of copies. In such a case, specify the number of copies on the printer driver side.

Check Point	Solution
Check whether the paper feed interval is set.	Open the Advanced Settings sheet of the printer driver and Adjust the Paper feed interval. → 3-6-2. Paper Feed Interval (P.89)

■ Print Quality Is Poor

Check Point	Solution
Streaks appear on the printout.	If you are using the printer at low temperature(14 degrees Celsius or less), open the Utility sheet in the printer driver then select the [Low Temperature Print Mode] in the [Special Settings]. → 3-7-4. Special Settings (P.111)
White spots due to missing colors.	Open the Utility sheet of the printer driver and perform Cleaning. → 5-1-1. Cleaning (P.135) If the problem persists even after performing [Cleaning] contact a dealer from which printer was purchased or our sales shop.
Printout is faint.	See the action corresponding to the above-described check points “Streaks appear on the printout” and “White spots due to missing colors.”
Misalignment of colors appears.	Open the Utility sheet of the printer driver and perform Printhead Position Adjustment. → 5-2 Adjusting the Printhead Position (P.137)
Half-toning is rough.	Select [Error diffusion] for [Half-tone Process] in [Detailed Settings] on the Color sheet of Printing Preferences of the printer driver. But the printing speed becomes slow. → 3-4-5. Halftone Process (P.76)
Color unevennesses appear around characters or in solid imaging areas.	Set either of the following, and retry printing. <ul style="list-style-type: none"> • Set Halftoning of Color sheet in Error Diffusion in Options of Printing Preferences of the printer driver. But the print speed becomes slow. → 3-4-5. Halftone Process (P.76)

Check Point	Solution
The overall print quality is poor.	The use of dedicated paper for color card printer is recommended. Using paper that is not dedicated may possibly lower the quality of printing, and further lead to jamming and malfunctions.

■ Printed Colors Appear Strange

Check Point	Solution
Wrong colors are printed.	<p>Open the printer driver and adjust the Detailed Settings dialog box and the Color sheet.</p> <p>→ 3-3 Using the Color Dialog Box (P.66)</p> <p>→ 3-4 Using the Detailed Settings Dialog Box (P.72)</p> <p>Open the Control Panel of your computer, and then check whether the settings in the [Display Properties] or [Screen Properties] are correct. Especially when the setting of the display type or gamma coefficients is wrong, correct colors are not displayed on the display.</p>
The overall print quality is poor.	<p>It is recommended that paper exclusively for the color card printer be used. Using non-exclusive paper can degrade the print quality. It can also result in a paper jam or failure.</p> <p>→ 3-2-6. Paper Type (P.61)</p>
Image is too bright or too dark.	<p>Select "Photo", "Contains graphics", or "Use ICM" in [Color Adjustment] on the Color dialog box in the [Print Settings] dialog box of the printer driver, and then set [Brightness] or [Level Correction] in [Detailed Settings].</p> <p>→ 3-3 Using the Color Dialog Box (P.66)</p> <p>→ 3-4 Using the Detailed Settings Dialog Box (P.72)</p>
The image contrast is too strong or weak.	<p>Adjust the contrast in [Detailed Settings] on the Color sheet of Printing Preferences of the printer driver.</p> <p>→ 3-4-3. Density (P.74)</p>

Check Point	Solution
Image is faint.	Try setting the sharpness in [Sharpness] in [Detailed Settings] on the Color sheet of Printing Preferences of the printer driver. → 3-4-7. Sharpness (P.78)

■ Printing In One Color

Check Point	Solution
The printer driver is set to print in single color.	Open the Color sheet in the printer driver and check the Single Color Setting. → 3-3-3. Single Color Setting (P.70)
The software application is set up for single color printing.	Some software applications may allow you to print in one color. Check the print settings in the software application on the computer.

■ Others

About the remaining ink level detection function

The ink tanks of this printer have a remaining ink level detection function to prevent running out of ink during printing and printer failures.

→ [4-2-3. Viewing Ink Information \(P.131\)](#)

When an ink tank which has become empty is reinstalled, the remaining ink level detection function can be disabled.

Important

- When printing is performed with the remaining ink level detection function disabled, damage to the printer or a trouble can result.
- Swiftcolor/Kanematsu is not responsible for any failure resulting from the use of an ink tank refilled with ink.
- If the remaining ink level detection function is disabled for an ink tank, the remaining ink level detection function for the ink tank cannot be enabled again. To enable the remaining ink level detection function, replace the ink tank with a new ink tank exclusively for Swiftcolor SCC-4000D.
- If the same ink tank is removed and inserted many times, the joint between the ink tank and printer can be damaged and consequently ink can leak from the ink tank, damaging the printer.

The procedure for disabling the remaining ink level detection function is described below.

1

A warning error message is displayed on the [Status Monitor].

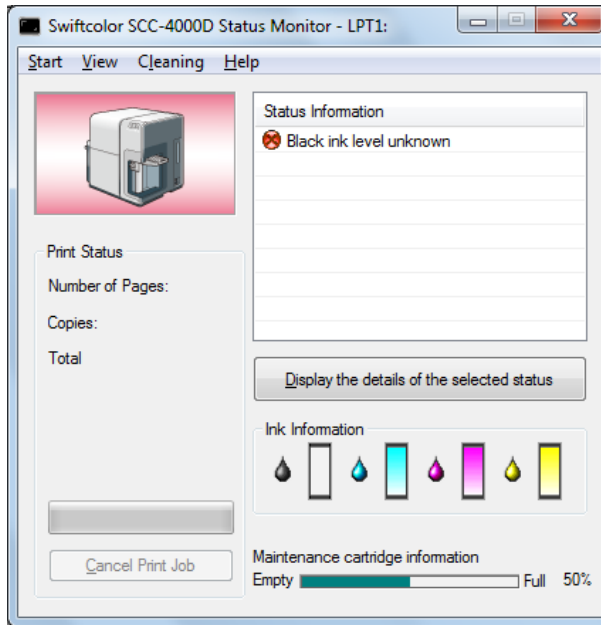

Clicking "Display the details of the selected status" displays the Status Monitor Help.

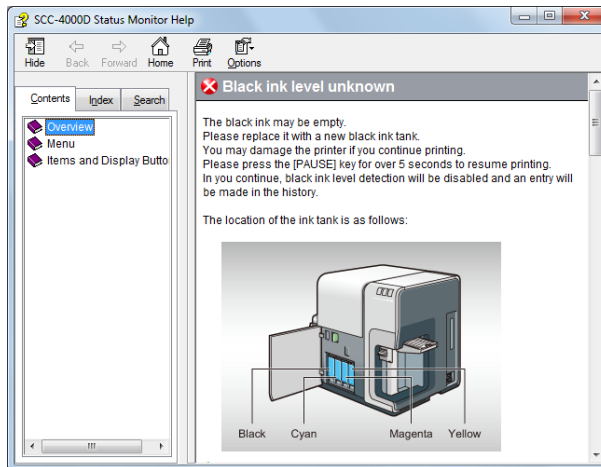

2

Press down the [PAUSE] key on the operation panel for at least 5 seconds.

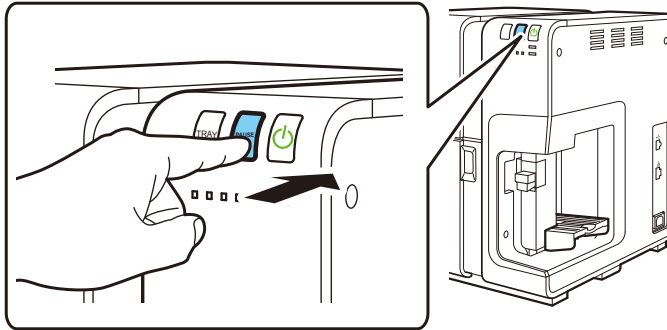
**3**

The remaining ink sensor function is disabled and the Status Monitor displays [Stopping XXXX ink level detection].

The remaining ink indication in the ink information is grayed out.

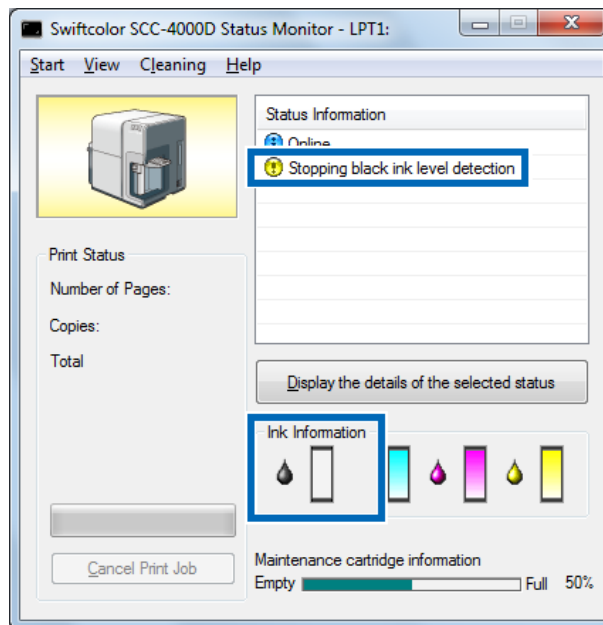

Note

- The message on the [Status Monitor] disappears and the corresponding color lamp on the printer goes out when a new ink tank for Swiftcolor SCC-4000D is installed in the printer.

7. Appendix

7-1 Moving The Printer

After moving the printer on the same floor or to another floor, install it properly following the procedure described below.

Caution

- This product weighs about 25 kg. Two persons standing at the front and back of the printer must lift the printer while holding the left and right handles provided at the bottom of the printer. If you lift the printer in an unnatural posture, you may drop it, resulting in an injury. In addition, if you hold the feeder section or auto stacker (paper eject section), you may damage it or drop the printer, resulting in an injury.

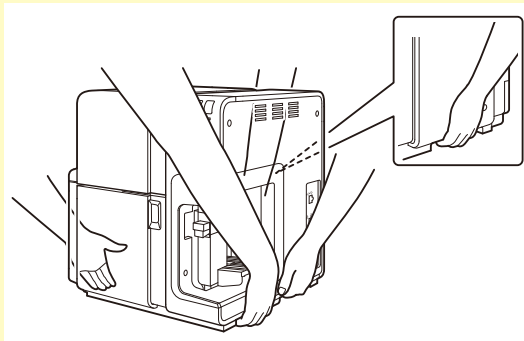

- Always hold the printer level and carry it slowly. If ink is spilled inside the printer while moving it, this could cause a fire or serious electrical shock or damage the printer.

1

Right-click on the printer driver icon, select [Printer Properties], and then click the [Utility] tab.

2

Click [Moving The Printer].

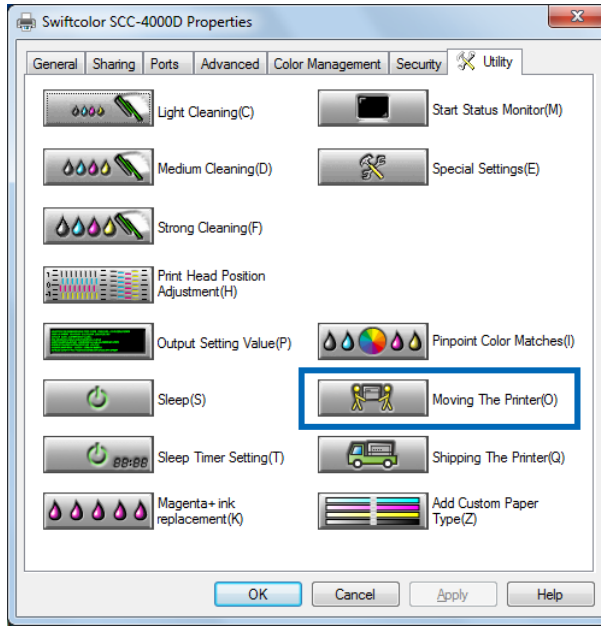

Important

- If a warning is issued when you press the [Moving the Printer], refer to the following:

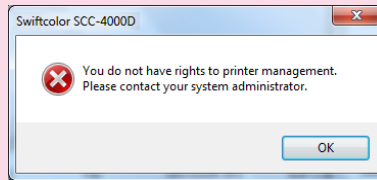

→ <To perform the above-mentioned operation using an authority other than the Administrator privilege.> (P.93)

3

Click [Yes].

The printer begins preparations for relocation, taking approximately 2 minutes.

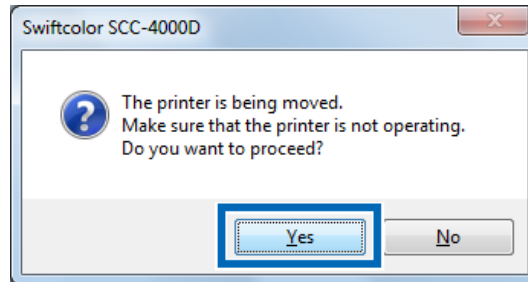
**Note**

- This preparation for moving the printer discharges ink inside the purge unit to prevent the ink from taking inside the printer.

4

When the printer has finished preparations, press and hold the power key for at least 1 second to turn off the printer.

→ [1-3-2. Switching the Printer Off \(P.15\)](#)

5

Disconnect the interface cable and power cord.

6

Move the printer.

Important

- Do not move the printer with the upper unit, ink tank door, or maintenance cartridge door open. The printer can break down or it can be damaged.
- To move the printer on the same floor or within the same building in, the ink tanks need not be removed. If the ink tanks are removed before moving the printer, ink can leak from the needle sections in the ink tank slots which may result clothes and surrounding work area stained.

7-2 Shipping the Printer

When transporting the printer over a long distance, be sure to observe the following precautions.

! Caution

- Call the Tech support for advice before you ship the printer a long distance or move the printer by car or truck where it may be subjected to shock and vibration. Moving the printer without the proper preparation could subject it to shocks and vibrations which could damage the printer and cause a fire.
- This product weighs about 25 kg. Two persons standing at the front and back of the printer must lift the printer while holding the left and right handles provided at the bottom of the printer. If you lift the printer in an unnatural posture, you may drop it, resulting in an injury. In addition, if you hold the stacker section or auto stacker (paper eject section), you may damage it or drop the printer, resulting in an injury.

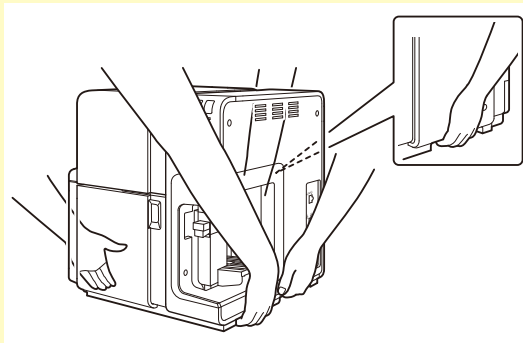

- Always hold the printer level and carry it slowly. If ink is spilled inside the printer while moving it, this could cause a fire or serious electrical shock or damage the printer.

1 Check that the warning message “Maintenance cartridge near full” is not displayed on the Status Monitor.

When the warning message is displayed, replace the maintenance cartridge with a new one, and then start the work.

2 Right-click the printer driver icon, select [Printer Properties], and then click the [Utility] tab.

3 Click [Shipping The Printer].

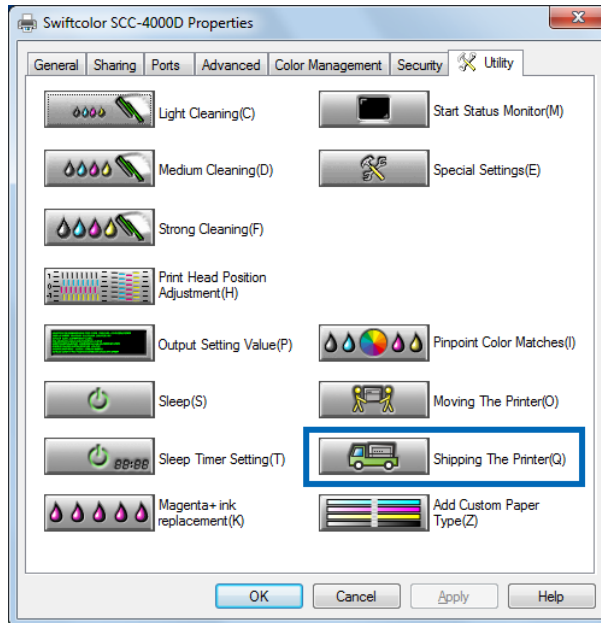

Important

- If a warning is issued when you press the [Shipping the Printer], refer to the following:

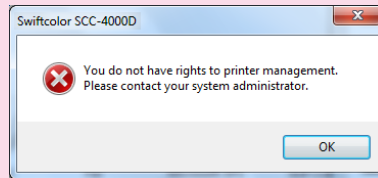

→ <To perform the above-mentioned operation using an authority other than the Administrator privilege.> (P.93)

4

Click [Yes].

The printer begins preparations for relocation, taking approximately twenty minutes.

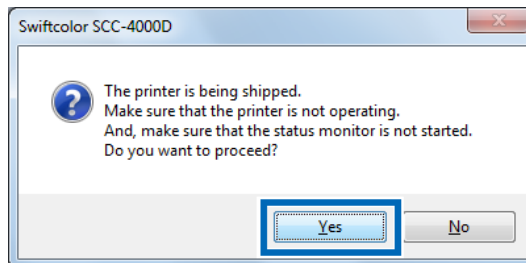
**5**

Pack the printer properly following the instructions of the dealer or service technician before transporting it.

Important

- Do not move the printer with the upper unit, ink tank door, or maintenance cartridge door open. The printer can break down or it can be damaged.
- Before transporting the printer, be sure to execute [Shipping The Printer]. If ink tanks are removed before [Shipping The Printer] is executed, ink leaking from the ink tank slots can stain your clothes and surrounding work area.

7-3 Software Uninstallation

This section explains how to uninstall the printer driver that has been installed on the computer. Before uninstalling the printer driver, close all applications running, check that all print jobs have ended.

- 1 Select [Swiftcolor SCC-4000D]-[Swiftcolor SCC-4000D Printer Driver Uninstall] from [All Programs] or [Programs] on the [Start] menu.

The uninstaller starts.

Note

- The [User Account Control] dialog box may appear at this time. If it appears, click [Yes] or [OK].

- 2 Click [Start].

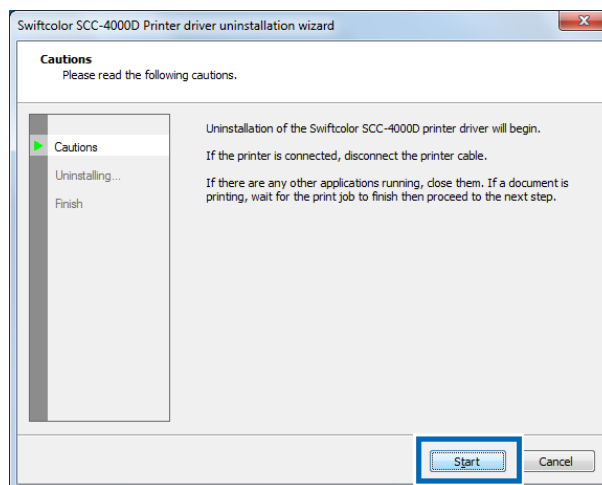

3 Click [Finish].

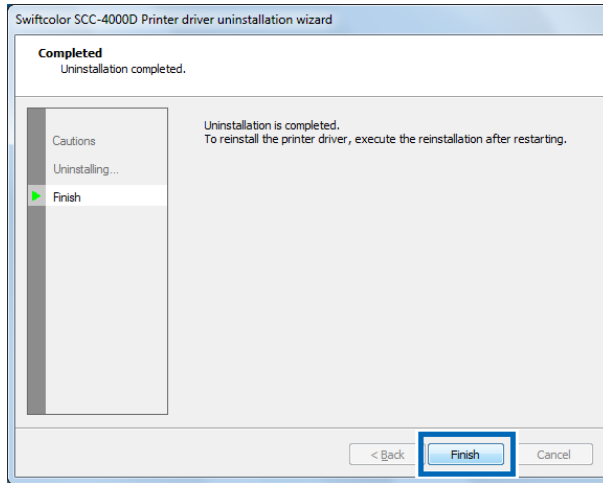

The [Changing System Settings] dialog box appears.

4 Click [Yes] to restart Windows.

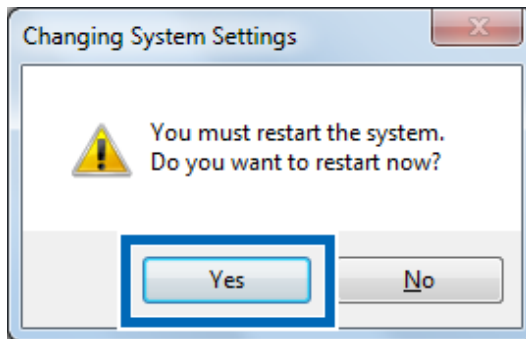

Note

- If [No] is clicked, be sure to restart the computer before installing the printer driver again.

7-4 Network Utility

This utility software is for searching and configuration of settings for printers connected to the network.

Important

- Install Network Utility in the course of installing the printer driver for network.
- When using Network Utilities, be sure to configure settings as Network Administrator.

1 Select [All programs] dialog box from the [Start] menu in Windows.

2 Click [Swiftcolor SCC-4000D Network IF].

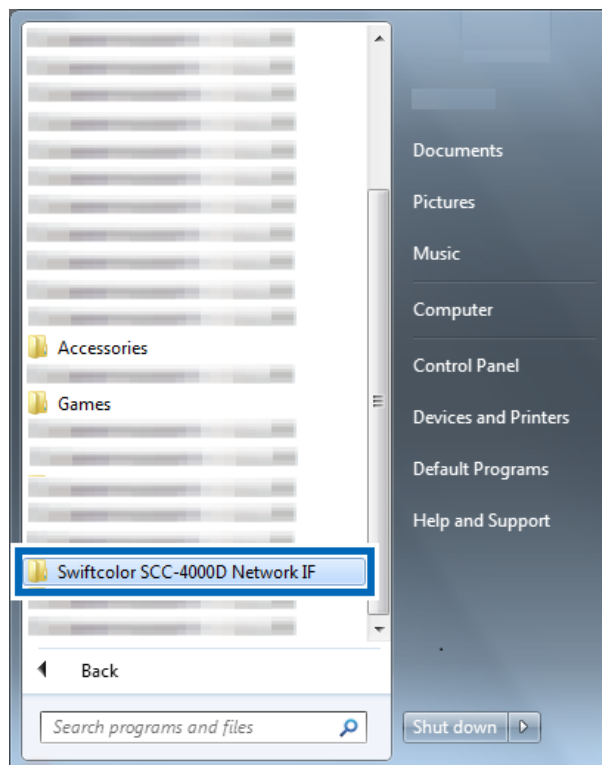

3 Click [Utility].

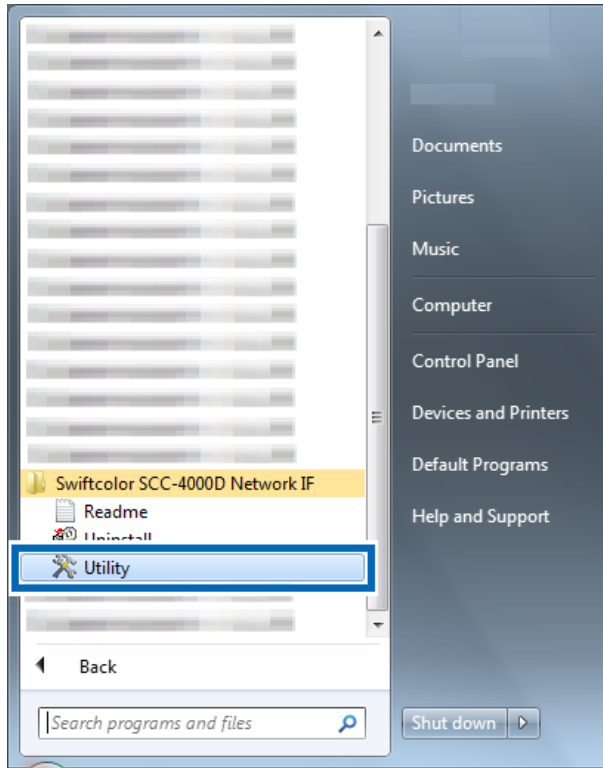

Searches for the printer on the network.

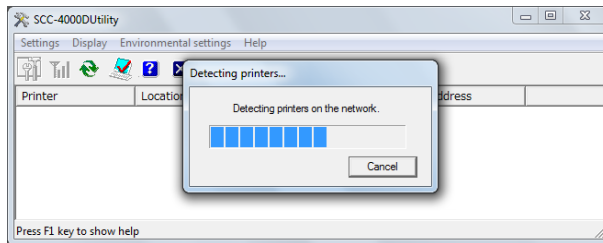

The [Network Utility] starts.

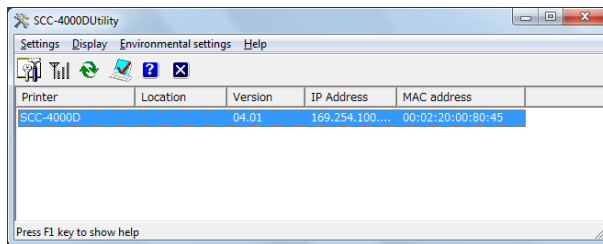

7-4-1. Toolbar

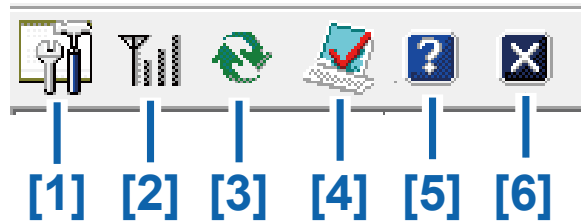

[1]	Printer setting	Opens the Network Settings window for a printer.
[2]	LAN status	Displays communication status of wired LAN.
[3]	Search for printers again	Searches for a printer again.
[4]	Environmental setting	Configures environmental settings of the Network Utilities.
[5]	Show utility help	Displays the Utility Help screen
[6]	Utility closed	Ends the Network Utilities.

7-4-2. Menu bar

Configure settings on the [Network Utility].

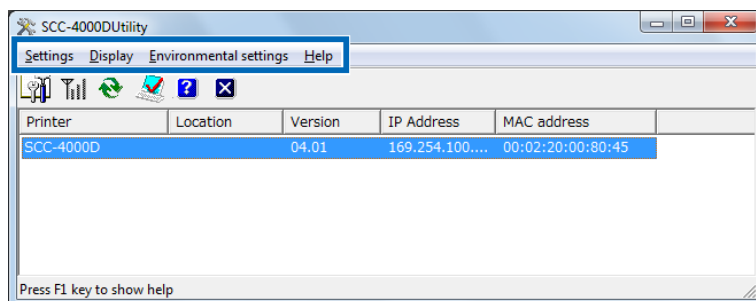

7-4-3. Settings

Click [Settings] on the menu bar and open the pull-down menu.

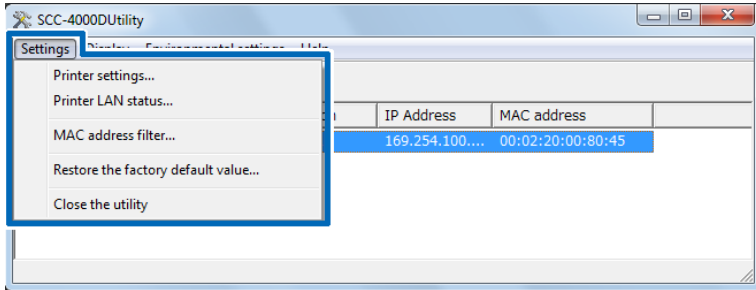

■ Printer Settings

- 1 Clicking [Printer Settings] on the pull-down menu opens the password setting dialog.

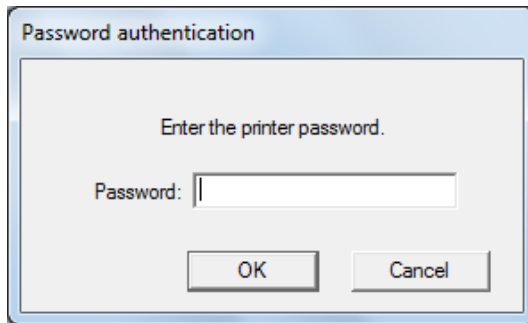

-Default password is [admin].

- 2 After entering password, click [OK].

3

Printer Setting window is displayed.

The [Basic settings], [TCP/IP], and [LOG settings] are described.

● [Basic settings]

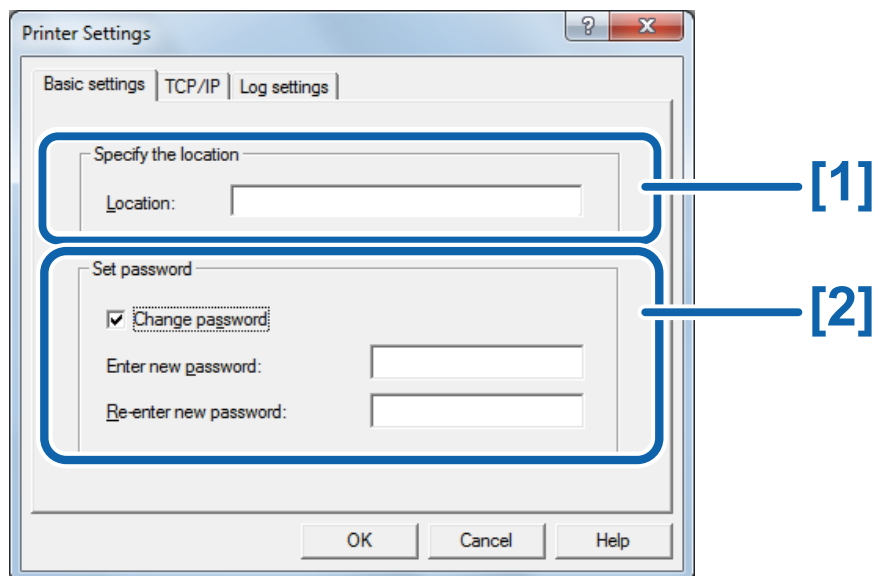

[1]	Specify the location	Enter the location of printer installed. *The number of characters that can be entered: 0 to 15 characters
[2]	Set password	Change the current password. *The number of characters that can be entered: 0 to 8 characters

● TCP/IP

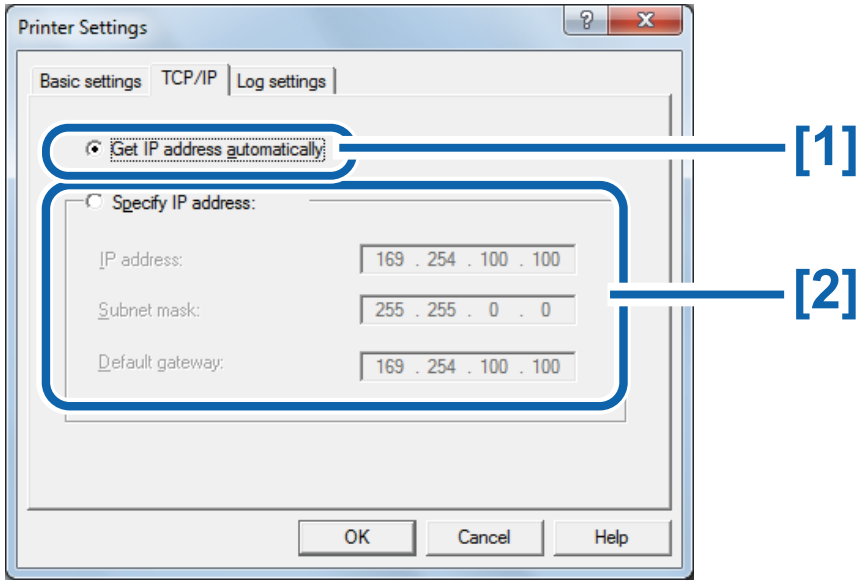

[1]	Get IP address automatically	Automatically obtains IP address.
[2]	Specify IP address	Specify IP address. Select this option when IP address is not obtained from the DHCP server.

● Log settings

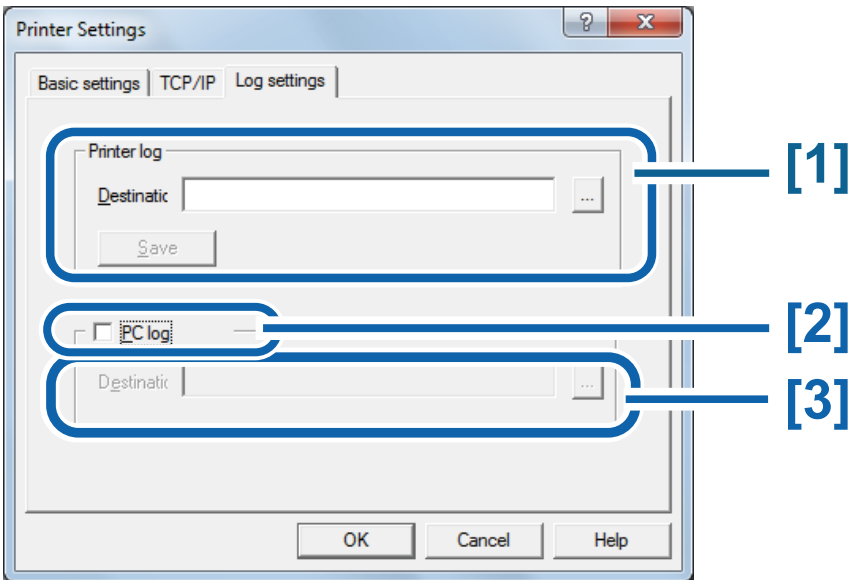

[1]	Printer log	Enter the location for the printer log file to be saved.
[2]	PC log	Check this check box when performing output for logs of the Network Interface Library to a file.
[3]	Destination	Enter save location for computer log.

4 Click [OK].

■ Printer LAN status

Check the network status obtained from the printer.

1 Click [Printer LAN status] on the pull-down menu.

Displays Network Status from printer.

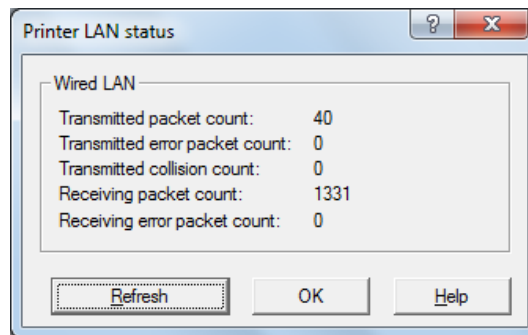

2 Click [OK] after confirmation.

■ **MAC address filter (Used when more than 2 printers are being used.)**

1 Click [MAC address filter] on the pull-down menu.

2 Password Setting dialog appears. Enter the password and Click [OK].

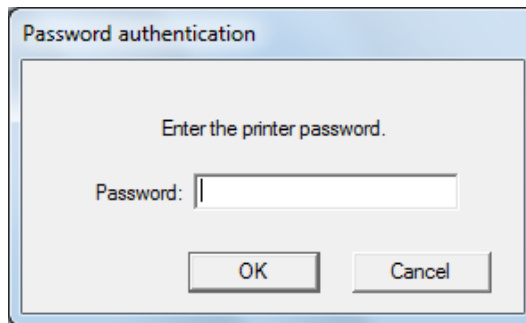

* Default password is "admin". However, if password is changed in [Basic Settings]of [Settings], that password will be in effect.

3

When [Mac address filter] window is displayed, check this check box and enter settings.

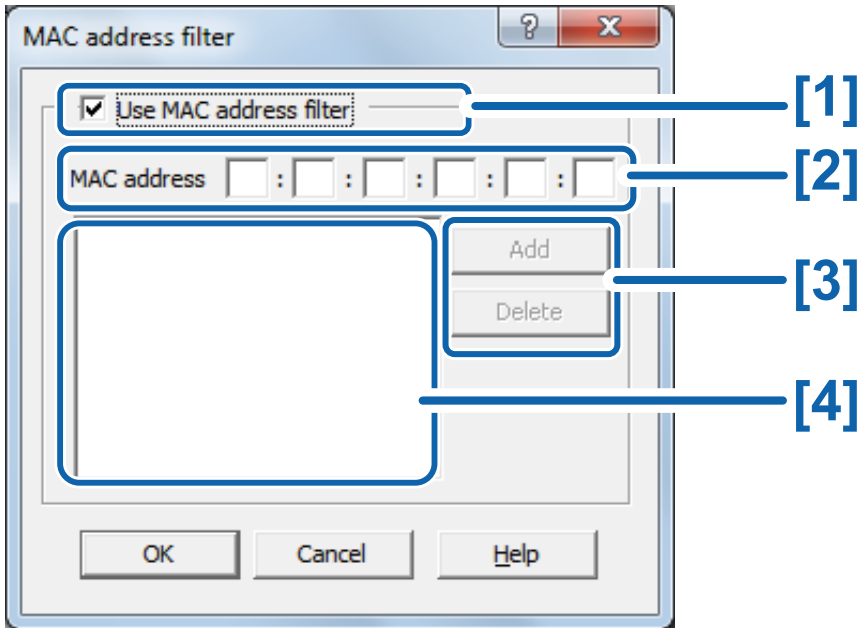

[1]	Use MAC address filter	Check this check box when using MAC address filter.
[2]	MAC address	Enter MAC address.
[3]	Add/Delete	Adds and deletes MAC address.
[4]	MAC address list	Displays the list of MAC addresses registered to the printer.

4

Click [OK] after setting is completed.

■ Restore the factory default value

1 Click [Restore the factory default value] on the pull-down menu.

2 Password Setting dialog appears. Enter the password and Click [OK].

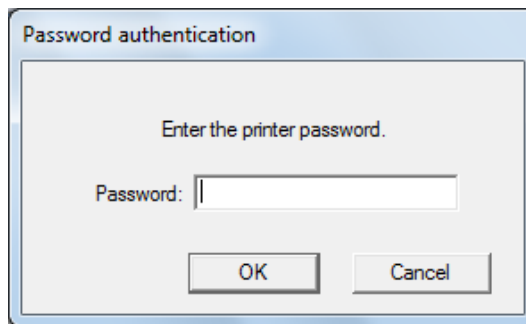

* Default password is "admin". However, if password is changed in [Basic Settings] of [Settings], that password will be in effect.

3 When the confirmation window opens, click [Yes].

7-4-4. Display

Click [Display] on the pull-down menu.

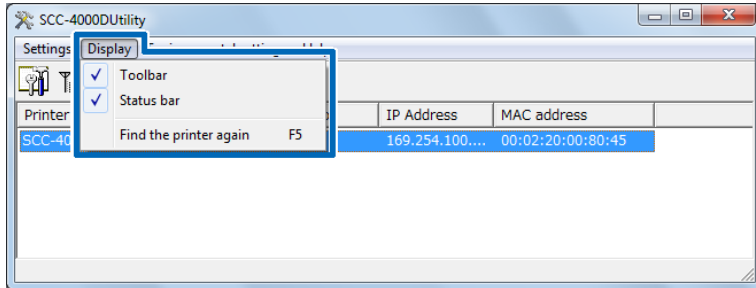

* The check box is checked by default. If unchecked, the [Tool bar] and [status bar] will be displayed.

7-4-5. Environmental settings

Click [Environmental Settings] on the pull-down menu.

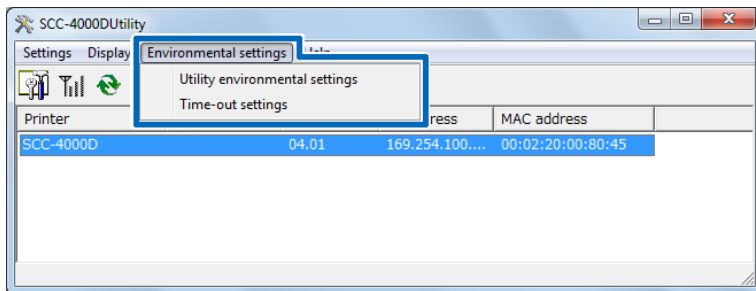

Utility Environmental settings

1 Click [Utility environmental settings].

● [Range of searching]

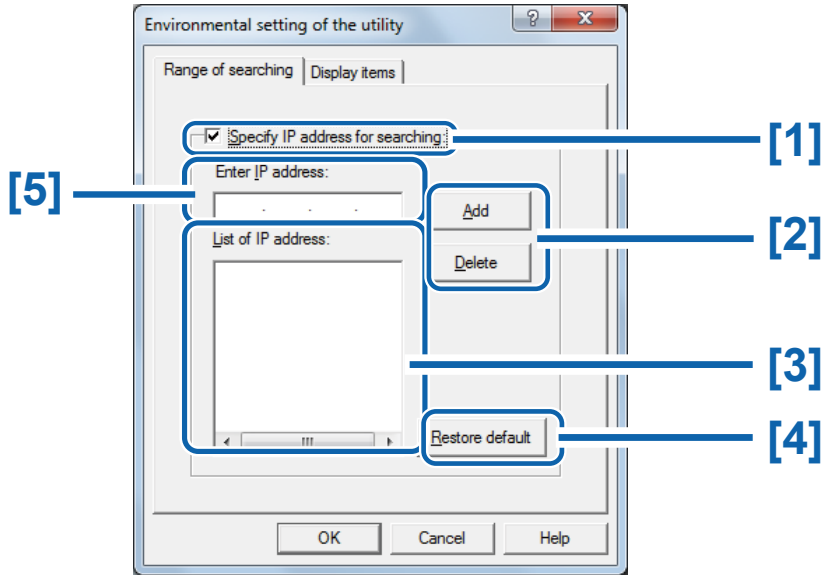

[1]	Specify IP address for searching	Check ON: When specifying IP address to search.
[2]	Add/Delete	Check OFF: Searching for a printer on the network.
[3]	List of IP address	Add or Delete IP addresses on search list.
[4]	Restore default	Displays the list of IP addresses to search for.
[5]	Enter IP address	Reset the search range setting to default.

● [Display items]

Select setting items to be displayed during start-up.

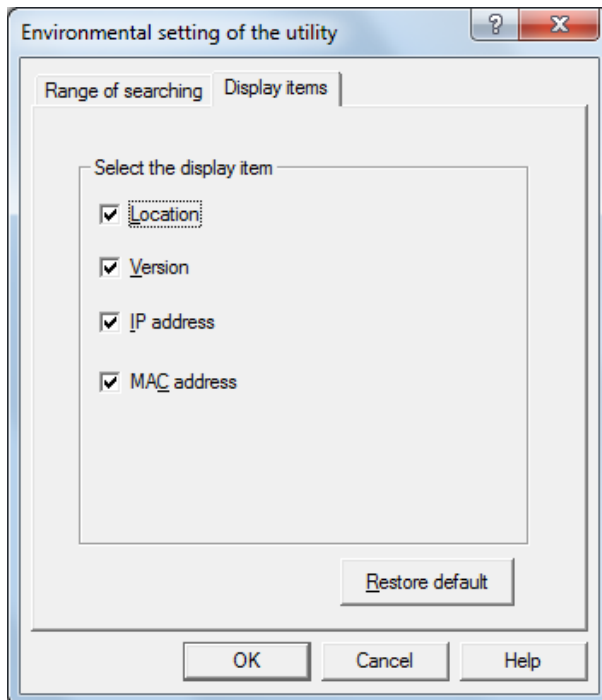

* Printer name is always displayed so it is not included in the selectable items.

2

Click [Environmental Settings] on the menu bar for a pull-down menu and click [Time-out Settings].

■ Time-out settings

Configure setting to extend the duration of network time-out to avoid resending print data.

- 1 Click [Time-out settings] on the pull-down menu.

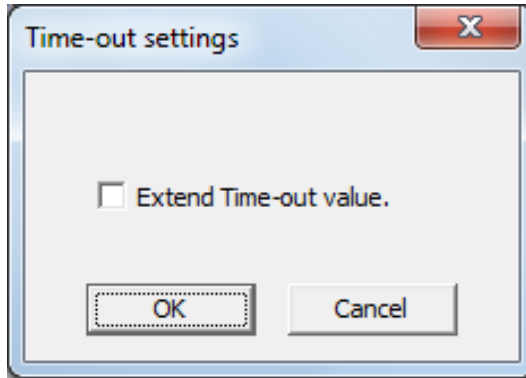

- 2 Check the [Extend Time-out Value] check box and click [OK].

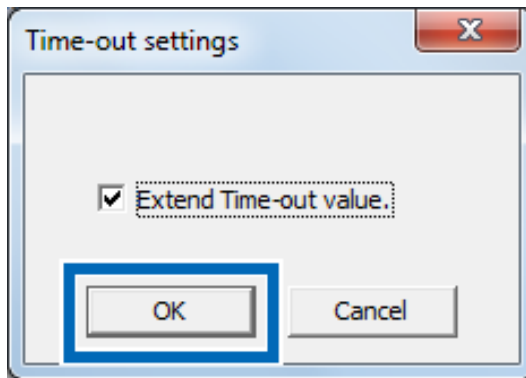

7-4-6. Help

1

Click [Help] on the pull-down menu.

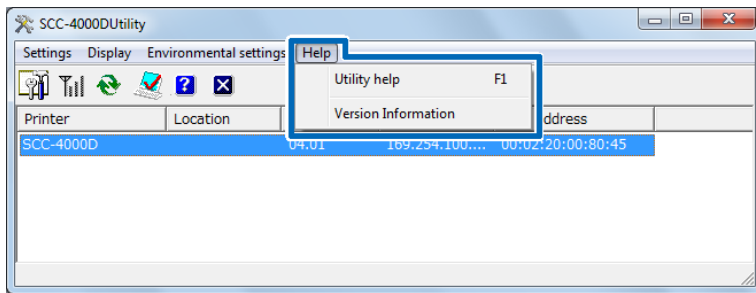

■ Utility Help

Click to display the Help of this utility.

■ Version information

Click to display the version of this utility.

After finished with all settings, click [Settings] on the menu bar and click [Utility closed] on the pull-down menu.

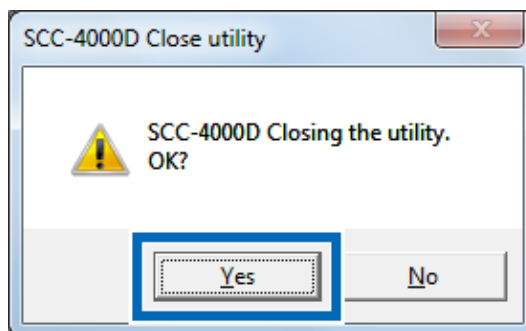

Click [Yes] to end.

Specifications

■ Printer

Printing method	Inkjet
Print colors	Full color
Output resolution	1200dpi×1200dpi
Printing speed	Business Card, ID-1(Plastic card): 100 sheets/min. Postcard: 45 sheets/min. Envelope: 28 sheets/min. Plastic card(3.5x5.5inch):50 sheets/min
Printable area	107.8 mm (W) × 297.0 mm (L)
Print margin (in relation to paper transport direction)	Top/Bottom: 1.5 mm Left/Right: 2.0 mm
Print head	5,097 nozzles (effective nozzles)
Paper	Matte coated paper, Glossy paper, Inkjet postcard, Envelope, Plastic card
Paper size	Width: 85 mm - 120 mm Length: 49 mm - 300 mm
Paper thickness	Business Card, Postcard, Plastic card: 0.21 mm - 0.76 mm Envelope: 0.28 mm - 0.32 mm
Paper feed capacity	Business Card, Postcard: 500 sheets (thickness 0.245 mm or less) Card/Plastic card (length :148mm or more): 100 sheets Envelope: 100 sheets
Ink used	Aqueous dye-based ink Yellow (Y), Magenta (M), Cyan (C), and Black (Bk)
Interface	Hi-Speed USB, 1000BASE-T/100BASE-TX/10BASE-T
Operating noise	About 58dB (A) or less
Installation environment	Temperature: 15 degrees Celsius - 30 degrees Celsius Humidity: 10% - 80% (with no condensation)
Power supply	AC 100-240 V, 50/60 Hz
Power consumption	Maximum power consumption: 229 W Sleep mode: 8.5 W
Dimensions	595 mm (W) × 410 mm (D) × 464 mm (H)
Weight	About 25 kg (without ink tanks and printhead)

- This printer employs a dye ink system. The colors in printouts may deteriorate due to chemical reactions caused by exposure to normal infrared light, nitrous or sulfuric fumes and other oxidizing chemicals in the air.
- To conserve the consumption of printing paper, the printer can print on the reverse side. To print on both sides of paper, use paper suited for duplex printing.

Index

Index

A		
Adjusting the Printhead Position	137	
Auto stacker	7	
B		
Brightness	73	
C		
Cleaning	135	
Color Balance	72	
Contrast.....	75	
Create Form	81	
Custom Paper Size	44, 56	
D		
Density 74		
Detailed Printhead Position Adjustment .	153	
E		
Error or Warning Messages	181	
F		
Fatal Error	185	
Favorites.....	43	
Feeder tray	6	
H		
Halftone Process.....	76	
I		
Ink Information	131	
L		
LAN port.....	5	
Level Correction.....	77	
Light Cleaning	36	
M		
Maintenance Cartridge Information	133	
Medium Cleaning	36	
Moving The Printer.....	92	
N		
Network Utility	211	
O		
Operation panel	5	
Operator Call Error Messages	181	
Orientation	44	
Others .	197	
Overlay Printing.....	84	
P		
Paper delivery slot	7	
Paper Feed Interval.....	89	
Paper is Jammed	186	
Paper Size.....	43	
Paper Size Preview	43	
Paper Type.....	44	
Pinpoint Color Matches.....	99	
Print Orientation Preview	43	
Print Status.....	125	

R

Rating plate 7

S

Sharpness 78
Shipping the Printer..... 205
Shipping The Printer 92
Side guide 6
Side guide lever 6
Sleep 94
Sleep Timer..... 96
Special Settings 111
Status Monitor 124
Strong Cleaning 36

T

Thick paper transport lever 7

U

Upper unit..... 6
Upper unit release lever 8
USB port..... 5

V

Viewing the Printer Status..... 127

W

Warning Messages 185

Contact Information

Swiftcolor/Kanematsu
KANEMATSU USA INC.
100 Randolph Road Somerset,
NJ 08873 USA
URL : www.swiftcolor.com
E-mail: info@swiftcolor.com

Kanematsu G.m.b.H
Duesseldorf Head Office
Oststrasse 34, D-40211, Duesseldorf, Germany
URL : www.swiftcolor.com
E-mail: info@swiftcolor.com